



ENGLISH

SMARTCODE 912

TOUCHPAD ELECTRONIC LEVER

Installation and User Guide

Required tools

4 AA Batteries Ruler Phillips head screwdriver

Additional Tools (depending on application)

Hammer Wood block

Kwikset
1-866-863-6584
www.kwikset.com

Parts in the box

| | | |
|---|-----------------------|------------------------------------|
| Latch | Exterior Assembly | Levers |
| "B" is not included. If needed, please contact Kwikset to order a drive-in latch for your lock. | Mounting Plate | Screws and accessories |
| Interior Assembly | Spindle | SmartKey Tool |
| | Keys | Strike |
| | | |

1 Prepare the door and check dimensions

If drilling a new door, use the supplied template and the complete door drilling instructions available at www.kwikset.com/doorprep.

A Measure to confirm that the hole in the door is 2-1/8" (54 mm).

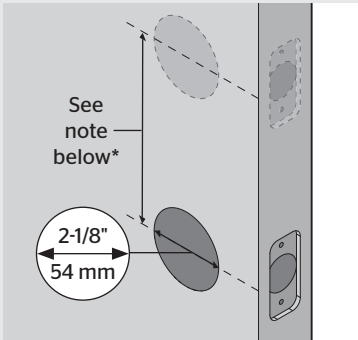

B Measure to confirm that the backset is either 2-3/8" or 2-3/4" (60 or 70 mm).

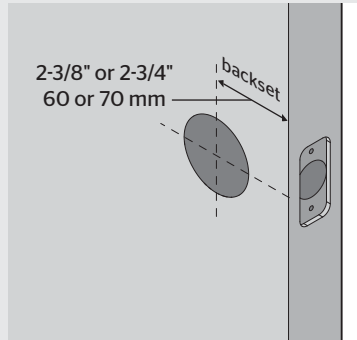

C Measure to confirm that the hole in the door edge is 1" (25 mm).

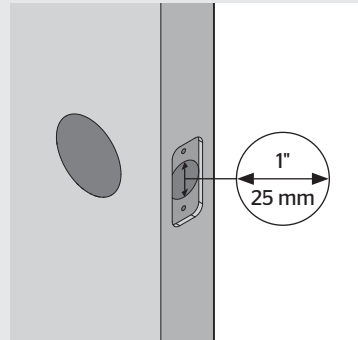

D Measure to confirm that the door is between 1-3/8" and 1-3/4" (35 mm and 44 mm) thick.

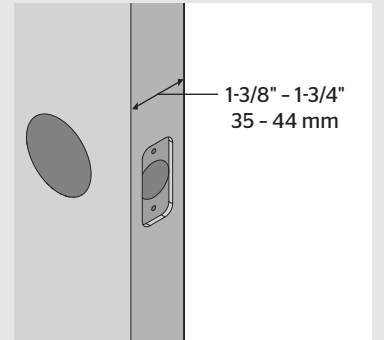

*If you are installing this lever below an existing lock or you plan to install a lock above this lever, make sure that the distance between holes is at least 6-1/2" (165 mm).

2 Install the latch and strike

A Hold the latch in front of the door hole, with the latch face flush against the door edge.

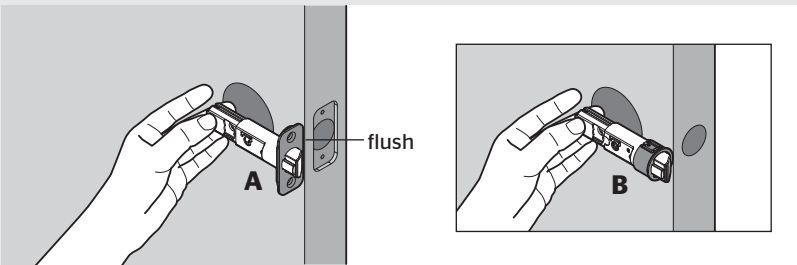

B Are the latch holes centered in the door hole?

YES **OR** **NO**

YES: No adjustment is required. Proceed to next step.

NO: Move the pin to extend the latch.

C Is the door edge chiseled?

YES **OR** **NO**

YES: chiseled

NO: not chiseled

YES: slant of latch bolt faces door frame

NO: slant of latch bolt faces door frame

D Install strike on the door frame.

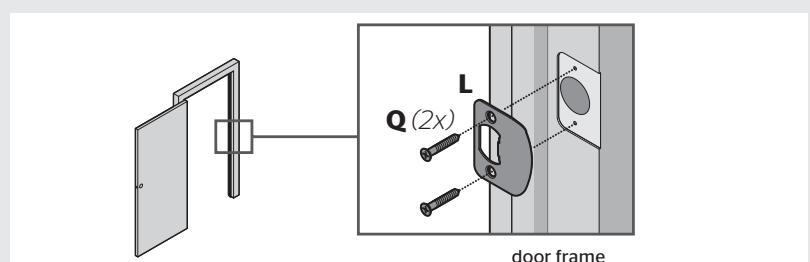

3 Install the exterior keypad, mounting plate, and spindle

A Install exterior keypad.

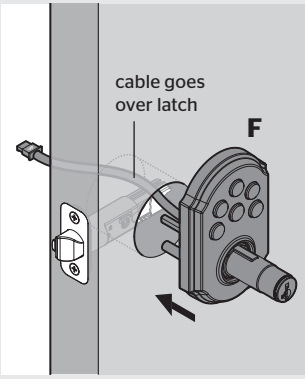

B Route cable through mounting plate.

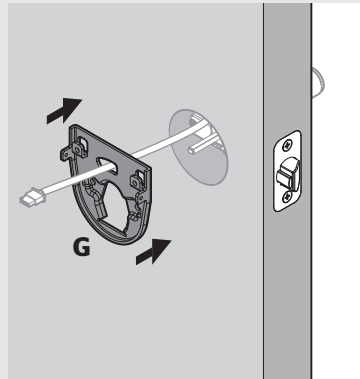

C Secure mounting plate with supplied screws.

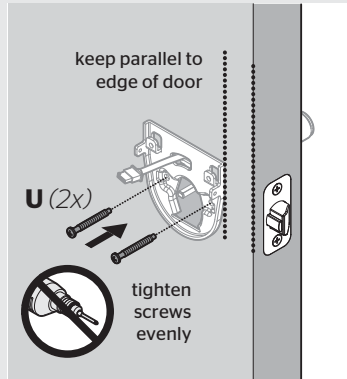

D Install spindle.

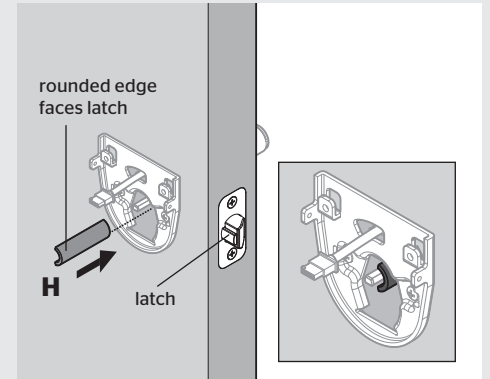

4 Install interior assembly

A Remove battery cover and battery pack from interior assembly.

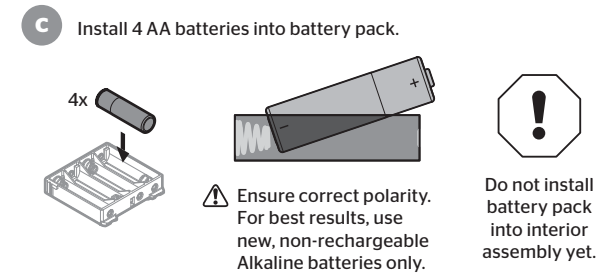
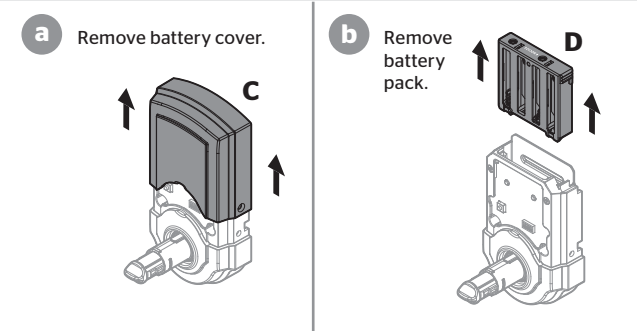

B Install interior assembly onto mounting plate.

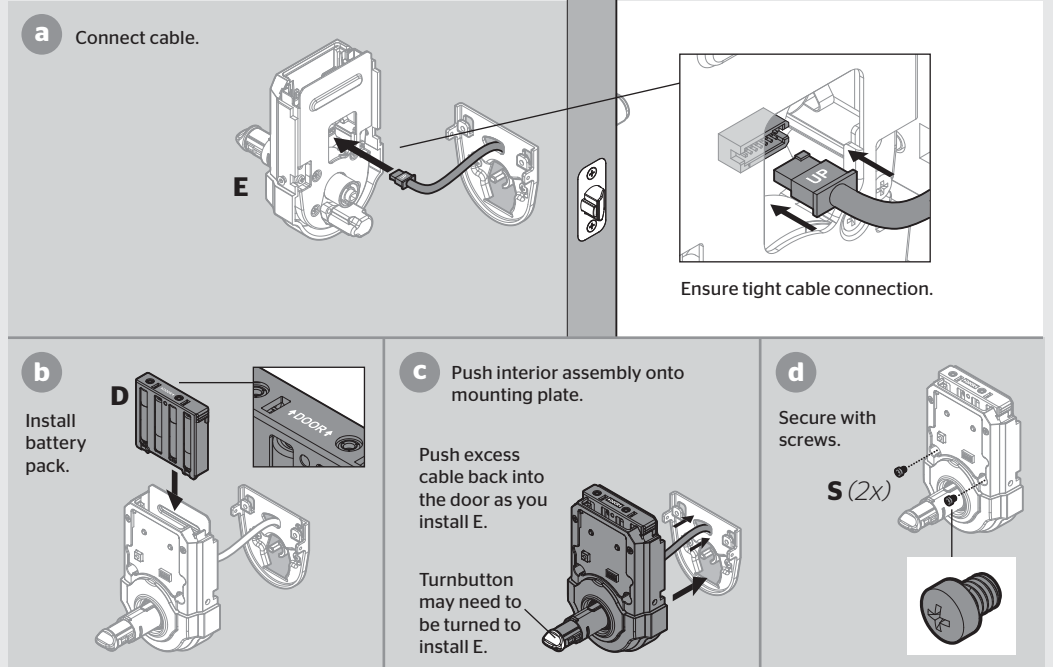

5 Install levers

A Install interior lever.

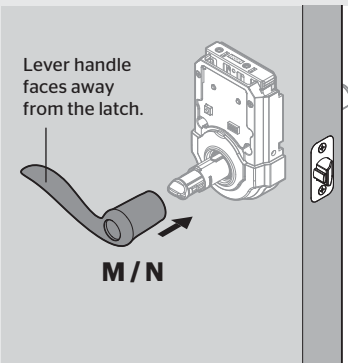

B Secure interior lever.

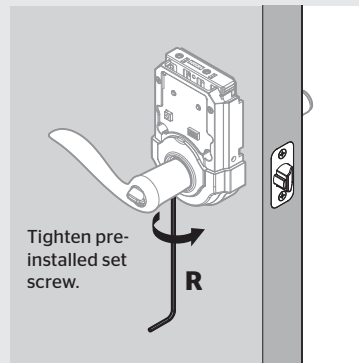

C Install exterior lever.

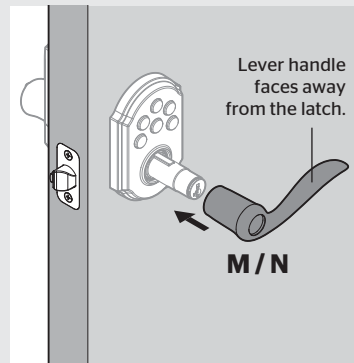

D Secure exterior lever.

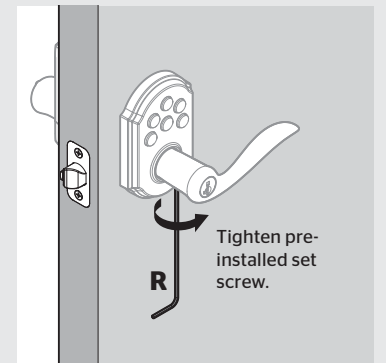

6 Test latch operation

Close door, test latch operation and make adjustments as needed:

The small bolt of the latch should not enter the strike hole. If it enters the strike hole, reposition strike.

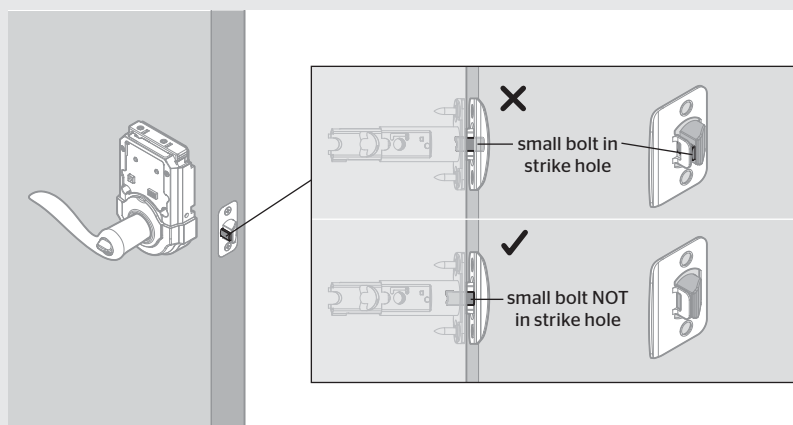

If latch is loose in the strike, adjust the strike tab so it grips the latch bolt better when the door is closed.

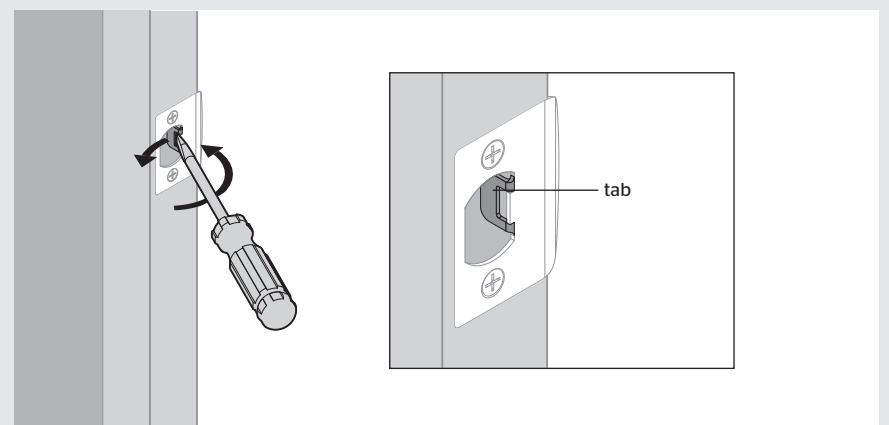

7 Pair the lock with your smart home system

A Initiate the pairing process at your smart home controller. Refer to your smart home system instructions for more information.

B When prompted by your smart home system to initiate pairing at the lock, press button "A" on the lock interior four times.

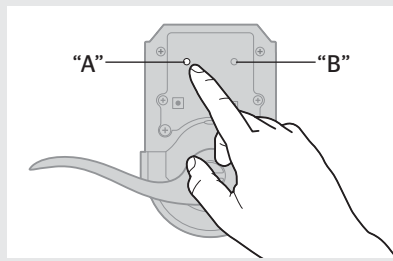

C If the pairing process is successful, re-name the lock in your system (if applicable).

D If the pairing process is unsuccessful, press button "B" nine times.

Perform steps 7A-7C again.

If pairing is still unsuccessful, consult the Programming and Troubleshooting Guide on the SmartCode 912 page at www.kwikset.com.

8 Add user codes (30 max)

It is recommended that you add and delete all user codes through your smart home control system. If your system does not allow this, codes may be added directly to the lock as shown here.

Programming Timeout

If no button is pressed for 5 seconds, the system will time out and you will need to restart the procedure.

A Make sure the door is open. Press the Program button the number of times that corresponds to the user code position being programmed.

Example: If programming the third code, press the button three times.

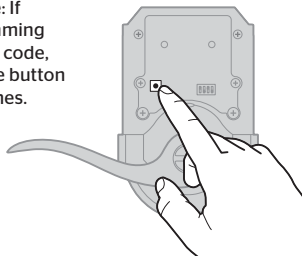

B Enter user code. A total of 30 user codes may be programmed.

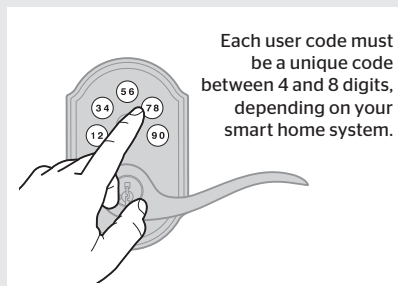

C Press Lock button once.

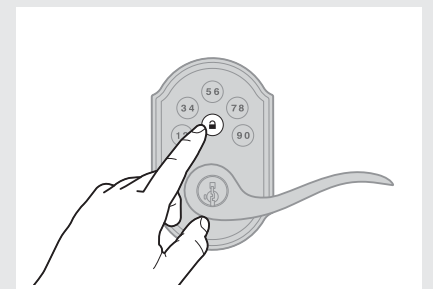

D What lights and sounds does the lock produce?

One green flash with one beep*

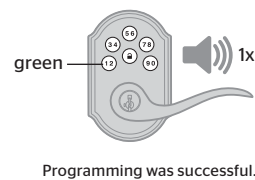

or

Three red flashes with three beeps*

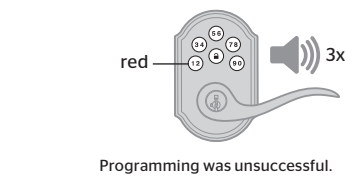

or

Two beeps*



Programming time out.

Make sure not to pause for more than 5 seconds during programming.

*Beeping sound will only be heard if switch #3 (on the lock interior) is in the on position. See "Switches and Status LED Colors" on page 4.

Mastercode

For enhanced security, a mastercode may be used when adding and deleting user codes. For more information about the mastercode, download the Programming and Troubleshooting Guide on the SmartCode 912 page at www.kwikset.com.

9 Test the lock (review normal operation)

Confirm that the code(s) added in step 8 can unlock the door.

Locking the Door

Press Lock button once.

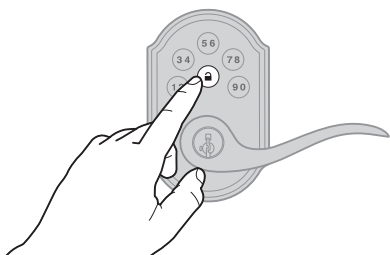

Unlocking the Door

Enter user code.

Tip: You can press the Lock button before entering your user code to light up the keypad at night.

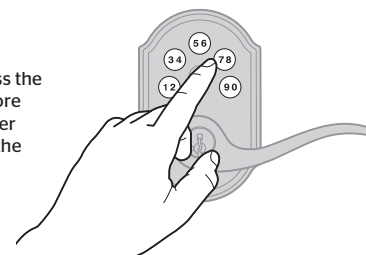

10 Re-key the lock (if needed) and install the battery cover

A Re-key the lock (if needed).

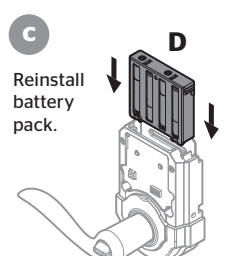
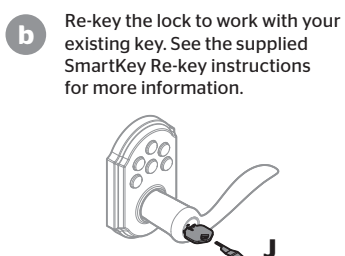
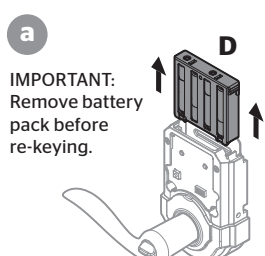

B Install the battery cover.

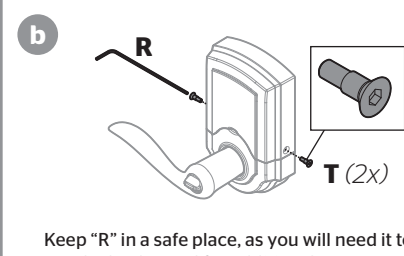
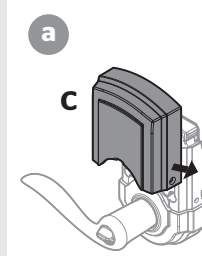

SmartCode at a Glance

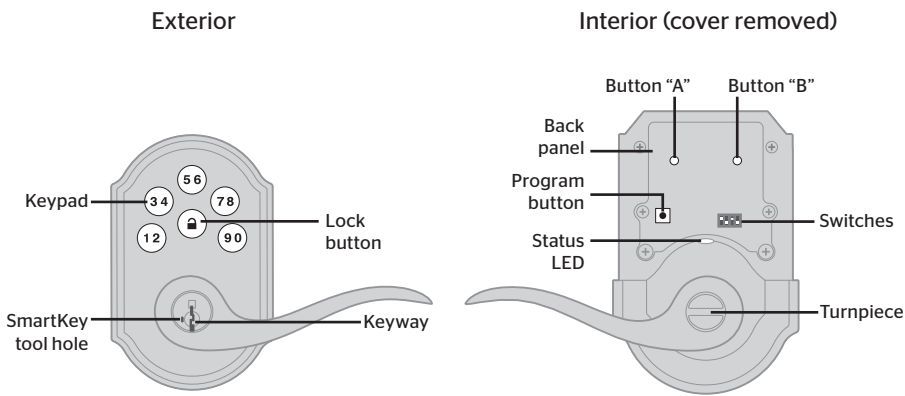

System Alerts

| Alert | Reason | Solution |
|--|--|--|
| Keypad flashes red 1 time with 1 beep* | Door jammed while attempting to lock. | Manually re-lock door. If needed, reposition strike. |
| Keypad flashes red 3 times with 3 beeps* | Unsuccessful programming. | Attempt programming procedure again. |
| | One incorrect code entered. | Re-enter code. |
| | No user code programmed. | Program at least one user code. |
| Keypad flashes red 10 times with 10 beeps* | Low battery. | Replace batteries. |
| Lock beeps 2 times. | Programming timeout. | Attempt programming procedure again, making sure not to pause for more than 5 seconds. |
| Keypad flashes red 3 times. | | |
| Keypad flashes red 6 times with 6 beeps*. | | |
| Keypad flashes red 15 times with 15 beeps* | Three incorrect codes entered within one minute. | Re-enter code after 60 second keypad lockout. |

*Beeping sound will only be heard if switch #3 is on.

Switches and Status LED colors

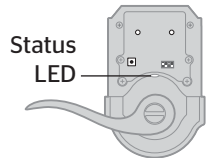
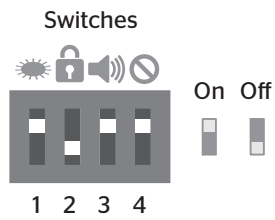

| Switch | Function |
|--------|---|
| 1 | Door lock status LED blinks every 6 seconds |
| 2 | Lock automatically re-locks door 30 seconds after unlocking. Disabled if no codes are programmed. |
| 3 | Audio |
| 4 | Not used. |

| Color | Lock Status |
|-------|-------------|
| Green | Unlocked |
| Amber | Locked |
| Red | Low battery |

Deleting a user code

In order to delete a user code, you must override the code by adding a different user code in the same position. For example, if you want to delete the third code, add a different user code in position three.

⚠ Test the old user code to make sure it can no longer unlock the door.

If you cannot remember the user code position, you may wish to perform a factory reset to delete all codes associated with the lock.

Troubleshooting

A complete Programming and Troubleshooting Guide is available on the SmartCode 912 page at www.kwikset.com.

Battery Replacement

If another lock is installed above the lever, remove the interior assembly when battery replacement is required.

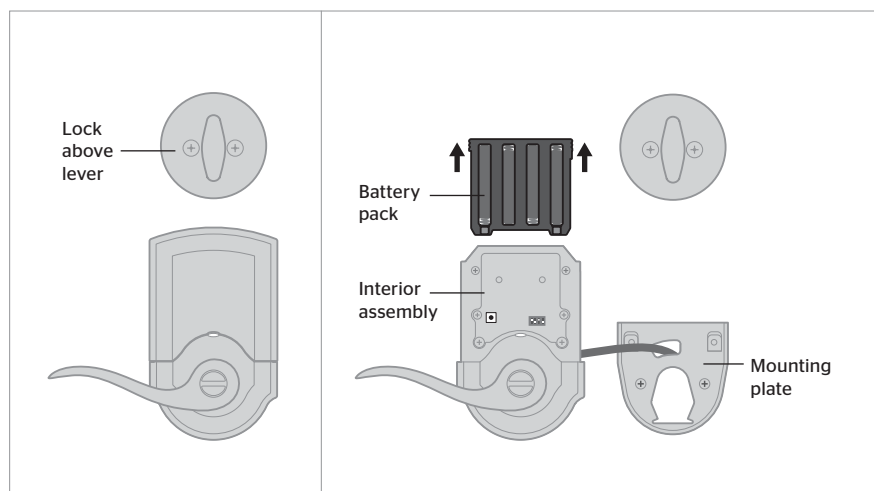

Factory Reset

A factory reset will delete all codes associated with the lock, and it will remove it from your smart home system.

1 Remove battery pack.

2 Press and HOLD the Program button while reinserting the battery pack. Keep holding the button for 30 seconds until the lock beeps and the status LED flashes red.

3 Press the Program button once more. When the LED flashes green and you hear one beep, the lock has been reset.

4 Pair the lock with your smart home system, and add user codes to your lock.

Network Information

ZigBee System Notes

ZigBee is a "Wireless mesh network," and results may vary based on building construction and communication path, with 35+ feet being typical installed distance in a standard home environment and 250 feet+ when the lock has a clear line of sight with the smart home controller. It may be necessary to install additional ZigBee devices to enhance the communication path between the lock and controller for a more robust ZigBee network.

Adding the lock to the network

During the pairing process, press button "A" on the lock interior four times.

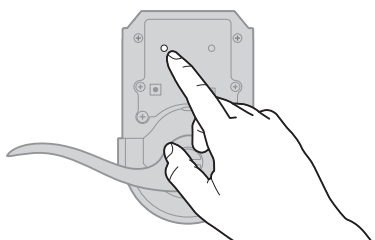

Removing the lock from the network

Press button "B" on the lock interior nine times.

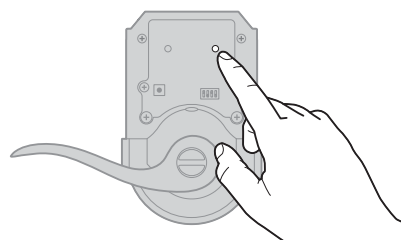

Important Safeguards

1. Read all instructions in their entirety.
2. Familiarize yourself with all warning and caution statements.
3. Remind all family members of safety precautions.
4. Protect your user codes and mastercode.
5. Dispose of used batteries according to local laws and regulations.

⚠ **CAUTION:** Prevent unauthorized entry. Since anyone with access to the back panel can change the user codes, you must restrict access to the back panel and routinely check the user codes to ensure they have not been altered without your knowledge. The use of a mastercode can help protect your system's settings.

⚠ **WARNING:** This Manufacturer advises that no lock can provide complete security by itself. This lock may be defeated by forcible or technical means, or evaded by entry elsewhere on the property. No lock can substitute for caution, awareness of your environment, and common sense. Builder's hardware is available in multiple performance grades to suit the application. In order to enhance security and reduce risk, you should consult a qualified locksmith or other security professional.