

NEW AND IMPROVED

**PENN REELS**  
**FATHOM-MASTER**

**800-825**

**ELECTRIC DOWNRIGGER**

*Ultra-Violet Protection Black Housing*

*Some Of The New Features Are:*

- Automatic Electronic counting feature for every 100 ft. going up or down to a possible 999 ft. depth. No need to reset switch every 100 ft. when retrieving trolling weight, as in previous gray models.
- A dual fuse circuit in the downrigger that greatly reduces the possibility of electrical damage to the downrigger.
- Improved water resistant features on frame. Lid also features spray deflector around counter cup.
- For compact storage, the boom and boom-tip can be removed from the downrigger frame quickly and without tools (Model 825 only).
- By consumer request, a new black extra reinforced frame that is extremely resistant to ultra-violet rays.
- For greater reliability, a double-sealed water-tight up-down switch.

**ASSEMBLING YOUR  
FATHOM-MASTER® 800-825 DOWNRIGGER**

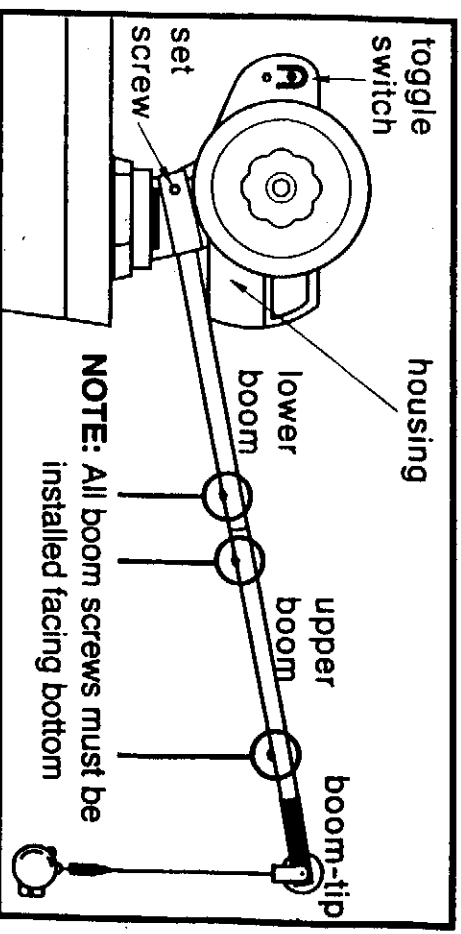
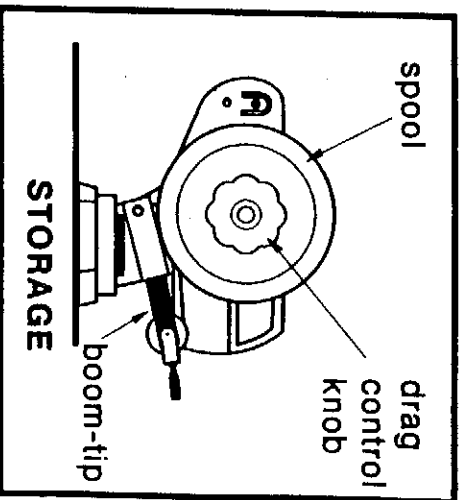

Mount and install according to the owner's manual.

When the power cord is plugged in, you will hear a long single "beep" indicating that power is running to the unit.

Back off the drag by turning knob counter-clockwise (maintain a slight tension on the spool).

Pull off the boom-tip along with the cable and connect to the boom (refer to illus. 1 & 2 below).

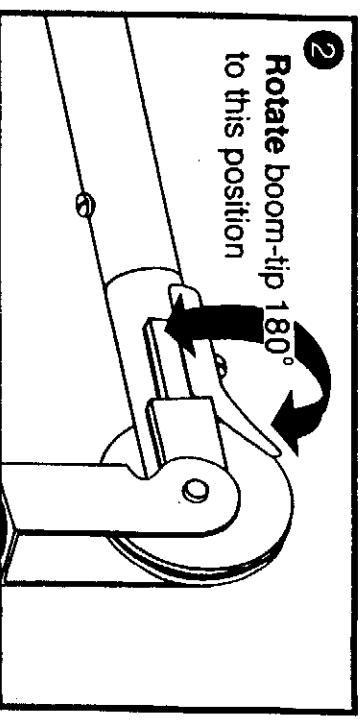
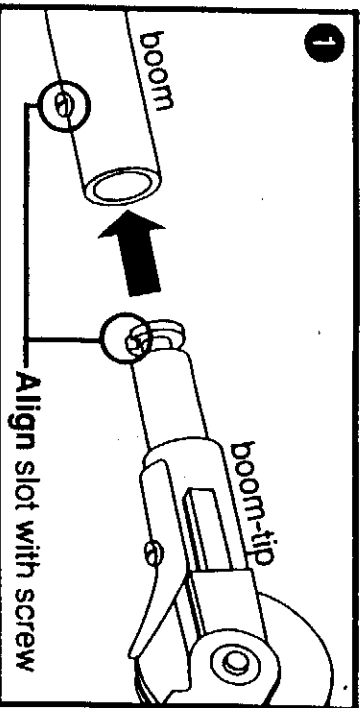

Insert boom-tip and boom(s) into downrigger housing. Remember to insert set screw on downrigger unit.

Re-tighten drag clockwise, leaving about 1ft. of cable down from the boom-tip.

Attach the weight, and tighten drag knob so that the trolling weight will not make the drag slip. Remember not to over tighten. You want the drag to slip under pressure if the weight snags the bottom, nets, etc.

**1**  
Align slot with screw

**2**  
Rotate boom-tip 180° to this position

# HOW USE YOUR FATHOM·MASTER® 800-825 DOWNRIGGER

## COUNTER SET-UP AND SWITCH OPERATION

### - Fishing With A Single Line Release -

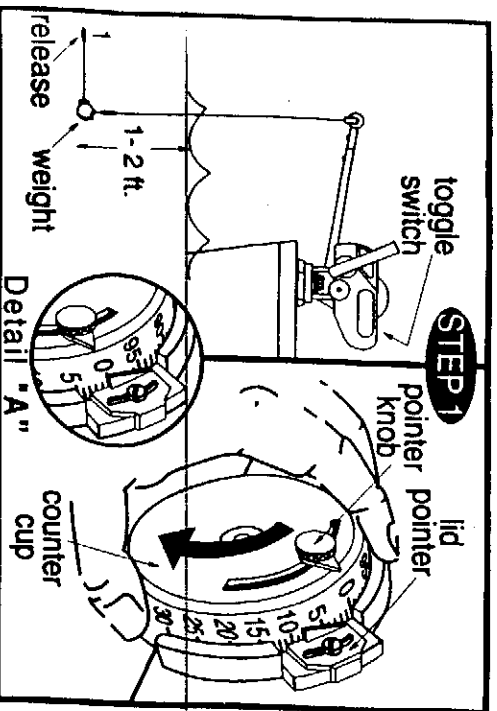

Now that the trolling weight is resting 1-2 ft. below the water level, grasp the counter cup and rotate it clockwise until the "0" lines up with the frame lid pointer. (refer to Detail "A")

#### FOR "STACKING" SKIP TO STEP 2

You are now ready to begin trolling. Lower the weight/release (push toggle switch DOWN) to reach the desired depth by referring to the counter cup reading.

**Remember to push the switch in the opposite direction for it to STOP.** Practice, lowering and raising the weight/release a few times. When raising the weight/release, it will automatically stop at "0" ft. mark. (1-2 ft. below water level). A short "beep" will sound.

Raise the weight/release out of the water up to the boom-tip for re-rigging by "Jogging" it.

To "Jog" the weight/release up, push the toggle switch UP and RELEASE. "Jog" in small increments to prevent the weight from accidentally slamming into the boom-tip.

**NOTE:** The "jog" feature (push switch & release) operates ONLY when the weight/release is going up, only after the counter passes the "0" ft. mark.

Push toggle switch to DOWN position to lower the weight about 1 - 2 ft. below water level (refer to step 1). Push switch in the opposite direction to STOP the weight.

**REMEMBER, whether you're raising or lowering the weight, to STOP, push the switch in the opposite direction.** The switch is spring loaded and will return to the center position after you push it in either direction.

### - Fishing With Multiple Line Releases "Stacking" -

Follow **step 1** of lowering the weight/release #1 to 1-2 ft. below water level, and turning counter cup clockwise to re-set to "0" ft.

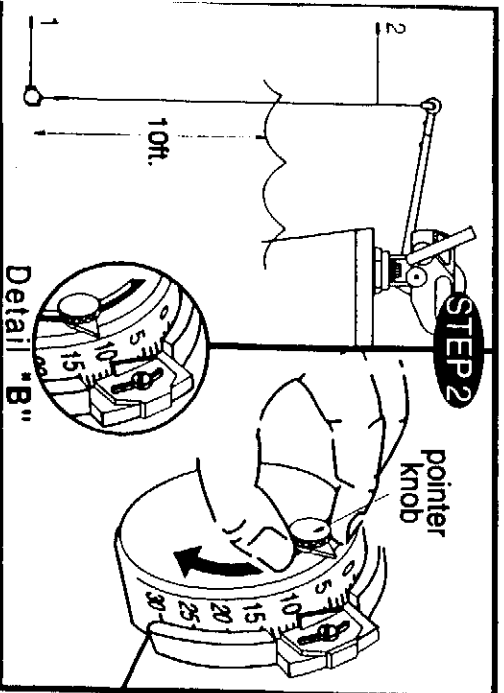

Then lower weight/release #1 down to 10 ft.

Attach your release #2.

To set the **Automatic Stop** (which prevents the weight and releases from slamming into the boom-tip!)

Unscrew the counter cup pointer knob slightly and slide it along until it matches the 10 ft. reading on the counter cup (refer to Detail "B"). A "beep" will sound.

**Do not unscrew the knob too much, because the pointer will fall out of place.**

**Retighten knob.**

You are now ready to begin trolling!

**- Fishing With Multiple Line Releases (continued) -**

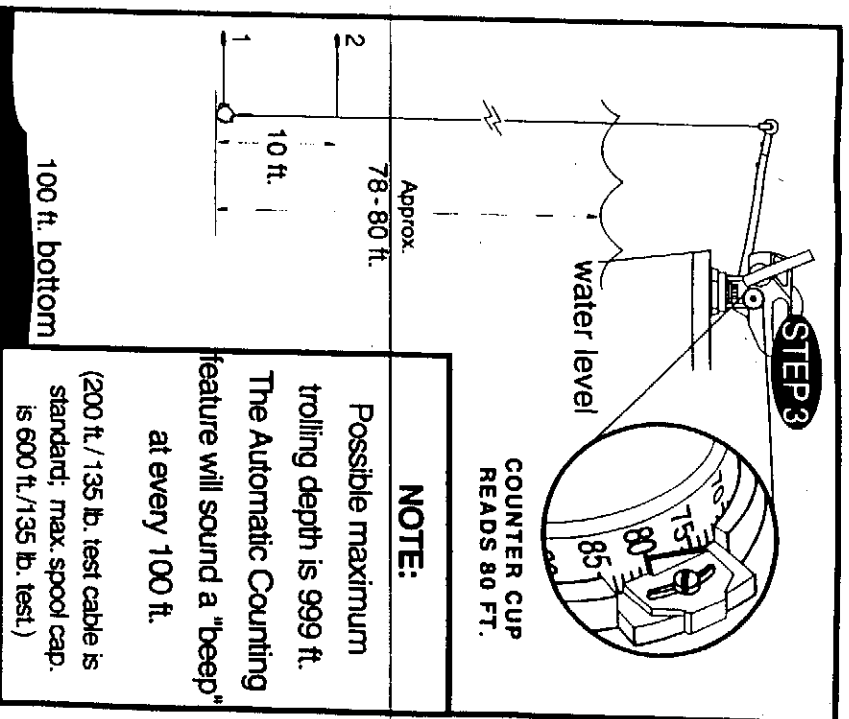

Lower releases, lines, and weight to desired depth, referring to the counter cup reading. (example-80 ft.)

After a strike or to raise releases and weight up to water level, push switch UP.

Release #2 will automatically stop as shown in step 2, just below the boom-tip, ready for re-rigging. A "beep" will sound.

At the same time, release #1/weight will be 10 ft. below the water level, as shown in step 2.

You must remove release #2 and "jog" release #1 and weight up the rest of the way for re-rigging.

**Before attaching your fishing line to the releases, practice lowering and raising the weight a few times. Good Downrigger Fishing!**

**ELECTRICAL INSTALLATION  
FATHOM-MASTER® 800-825 DOWNRIGGER**

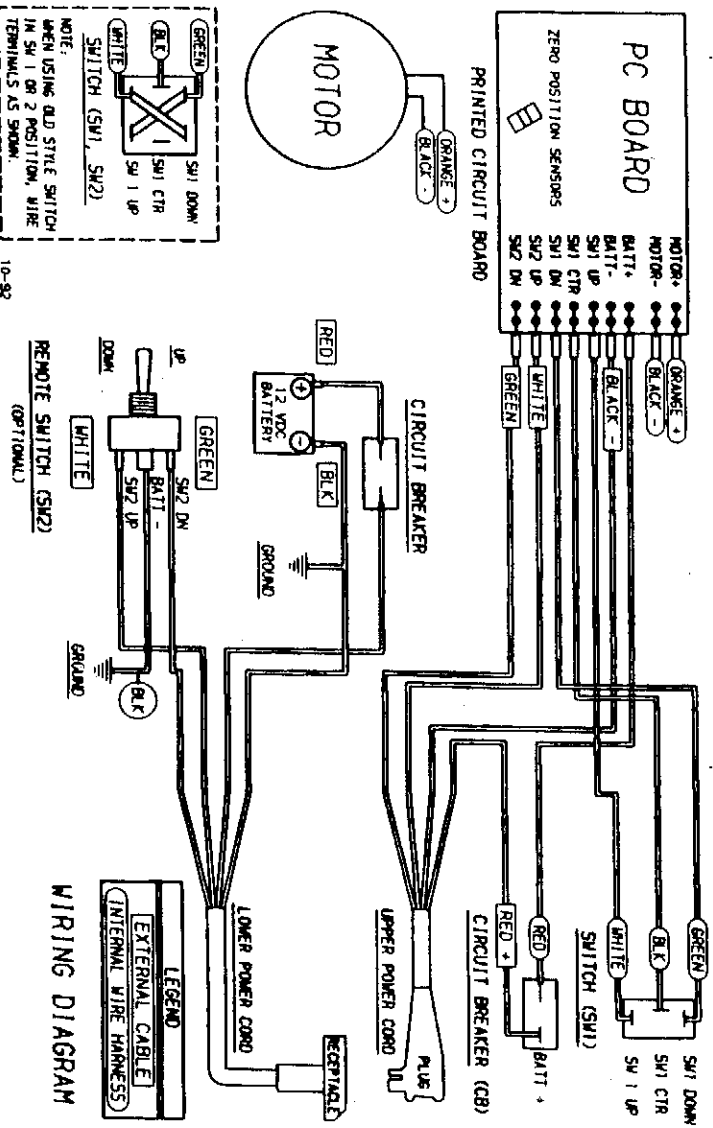

# NEW PARTS LIST FOR FATHOM-MASIEH 800/825 (Printed)

(Parts listed below are unique to the 800/825 models. See owner's manual for other parts.)

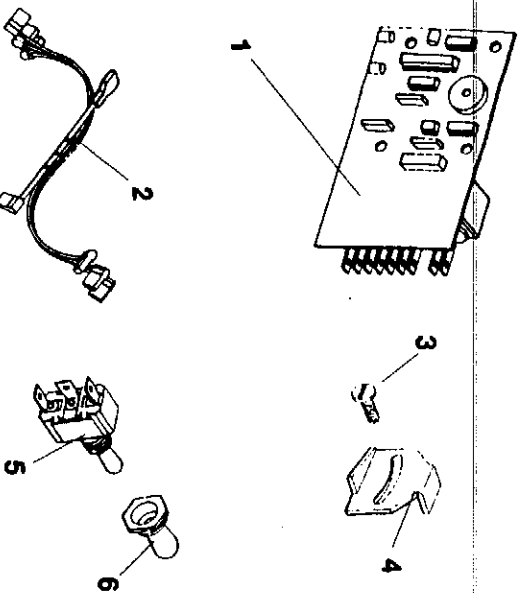

KEY NO.	DESCRIPTION	PART NO.
1	PC Board	507-825
2	Harness	515-825
3	Mounting Screw	63-349
4	Lid Pointer	305-825
5	Switch	503-825
6	Switch Boot	504-800

Please refer to the back cover of your owner's manual for warranty description and how to order replacement parts.

**NOTE: Discontinue use of the unit if the switch or circuit breaker is water damaged. Continued use may cause further damage and will void warranty.**

PENN FISHING TACKLE MFG. CO.  
 3028 W. HUNTING PARK AVE.  
 PHILADELPHIA, PA 19132  
 MADE IN U.S.A.