

Spinfisher 420SSG and 430SSG Bail Spring Issue

Background Information:

A recurring repair issue with the bail spring of the 420SSg and 430SSg Spinfisher reels has been the tendency for the torsion spring to fall out of the bail cam. This renders the bail wire and the reel useless.

Affected Reels: All Spinfisher 420SSG and 430SSG made before 6/1/2010
The rotor mold has been modified to prevent this issue on all future production.

Repair Procedure:

A repair part has been created (032A420G Bail Spring Spacer) that installs in the rotor arm so that the torsion spring leg is supported and will not back out of the bail cam. The spacer fits snugly around the support post and does not need special tools or adhesive.

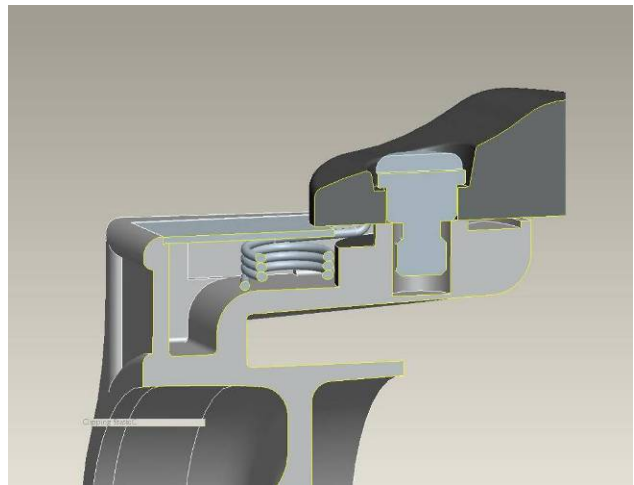

This allows service centers to quickly repair the reel without replacing the entire rotor assembly.