



Built to Grow Crib Assembly Instructions

IMPORTANT - RETAIN FOR FUTURE REFERENCE - READ CAREFULLY

Models:

BTG 2000 - Built to Grow Bravo Crib

BTG 2250 - Built to Grow Acclaim Crib

BTG 2500 - Built to Grow Debut Crib

Your little one will sleep secure in this YoungAmerica Crib. Proper assembly will ensure every effort has been made to design this crib with your baby's safety in mind. It is certified to meet all safety guidelines established by ASTM International and the CPSC-Consumer Product Safety Commission.



WARNING: FAILURE TO FOLLOW THESE WARNINGS AND THE ASSEMBLY INSTRUCTIONS COULD RESULT IN SERIOUS INJURY OR DEATH.

- When child is able to pull to a standing position, set the mattress to the lowest position and remove bumper pads, large toys and other objects that could serve as steps for climbing out.
- When a child is able to climb out or reaches the height of 35 in. (90 cm), the crib shall no longer be used.
- **DO NOT** place a crib near a window where cords from blinds or drapes may strangle a child.
- To reduce the risk of SIDS, pediatricians recommend healthy infants be placed on their backs to sleep, unless otherwise advised by your physician.
- To help prevent strangulation tighten all fasteners. A child can trap parts of the body or clothing on loose fasteners.
- **Strings can cause strangulation!** Do not place items with a string around a child's neck, such as hood strings or pacifier cords. Do not suspend strings over a crib or attach strings to toys.
- Before each usage or assembly, inspect crib for damaged hardware, loose joints, missing parts or sharp edges. **DO NOT** use crib if any parts are missing or broken. Contact your dealer or write to Stanley Furniture, 200 North Hamilton St, No. 200, High Point, NC 27260 for replacement parts and instructional literature if needed.
- **DO NOT** substitute parts. Use only bolts or parts supplied by manufacturer or parts of comparable quality and equal dimensions. Do not allow ends of bolts or sharp edges to be exposed.
- Follow warnings on all products in a crib.
- If refinishing, use a non-toxic finish specified for children's products.
- Infants can suffocate on soft bedding. Never add a pillow, comforter or padding. Never place additional padding under an infant.
- Infants can suffocate in gaps between crib sides and a mattress that is too small.
- Never use plastic shipping bags or other plastic film as mattress covers because they can cause suffocation.
- Do not allow child to crawl or play underneath crib.
- Use caution when a vaporizer is in use. Always aim the vapor steam away from the crib as well as away from any other wood furniture item.
- The crib must be fully assembled prior to use.
- Read all instructions before assembling crib. **KEEP INSTRUCTIONS FOR FUTURE USE.**

- **CAUTION:** Any mattress used in this crib must be at least 27-1/4" by 51-5/8" with a thickness of no less than 4 inches and not exceeding 6 inches.

When Converting to a Toddler Bed:

- **NEVER** use bed with children under 15 months of age.
- The maximum weight of the intended user shall not be greater than 50 lb (22.7kg).

Identifying the Parts

The crib illustrations in these instructions are generic in nature. The crib you have purchased may not look like the ones illustrated; however, they all assemble in the same manner.



Left Crib End

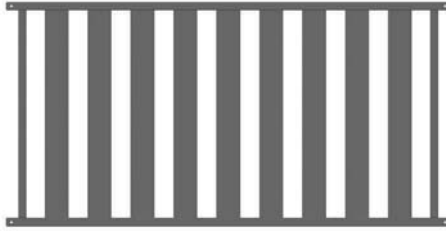

Mattress Platform



Right Crib End



Headboard

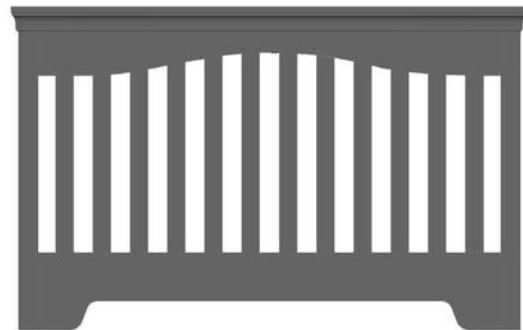

Footboard

Identifying the Hardware

Identify the hardware included using the illustrations below

8 Connector Bolts
2 3/8" (1/4" x 20 thread)



4 Headboard Bolts
2" (1/4 x 20 thread)



2 Metal Locator Pins
3/8" diameter x 1 1/2" long

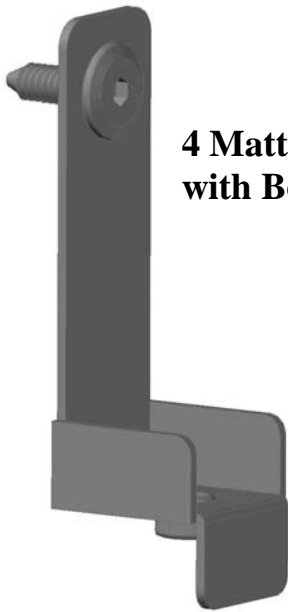

4 Mattress Brackets
with Bolts



2 Allen Wrenches

2 Hole Bolts (1" x 1/4" x 20 thread (For Headboard Only)
4 Hole Bolts (3/4" x 1/4" x 20 thread (For Footboard Only)
2 Caps (3/4" x 1/4" x 20 thread)

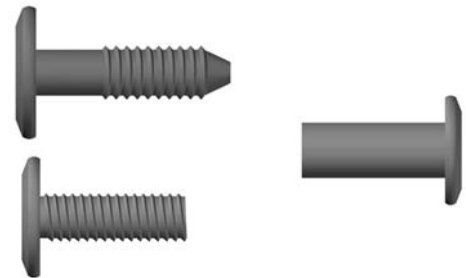

This hardware is for use when converting to a day bed and a full size bed.

Crib Assembly

NOTE: Read all instructions before assembling crib. KEEP INSTRUCTIONS FOR FUTURE REFERENCE.

Attached to the mattress platform is a sleeve to store the instruction booklet. After assembly is complete, return this instruction booklet to the sleeve for future reference.

This crib conforms to the ASTM International and the CPSC-Consumer Product Safety Commission guidelines for product safety. Please adhere to the guidelines in this booklet for assembly, use and maintenance.

Note the recommendations below:

- Power tools are not recommended for assembly.
- Give yourself plenty of room to work.
- Due to the size of this bed, it must be assembled in the space it will occupy.
- The assembly will take two people to complete.
- Layout all the hardware and make sure that the proper length bolts are used in the designated areas.
- Do not substitute hardware. If an item is missing or damaged contact Stanley Furniture Company immediately for replacement. Inspect all component parts and hardware prior to beginning the assembly process.
- Make sure all fasteners are tight.
- Above all, take your time and read the instructions carefully.

Tools required for Assembly:

- Allen Wrenches (provided)

This Crib is equipped with these additional features:

Bolt Retainer Sleeve—The Retainer Sleeves are located where Connector Bolts are used to assemble the crib. It is designed to prevent loss of the Connector Bolts after crib is disassembled. The Bolt Retainer Sleeves are permanently installed at the factory.

Attaching the Mattress Platform Brackets

Step 1:

- Locate the (4) Mattress Platform Brackets with attached assembly bolts as shown in Fig. 1. Determine the high or low position of the mattress foundation (Fig. 3) and attach the brackets on both the left and right end section in the same height location. (This is very important to keep the foundation level and your child safe).
- Attach the (4) brackets and tighten bolts using the wrench provided. See Figure 2.
- Make sure the brackets are straight and perpendicular to the crib uprights.
- When child is able to pull to a standing position, set the mattress platform to the lowest position and remove bumper pads, large toys and other objects that could serve as steps for climbing out.

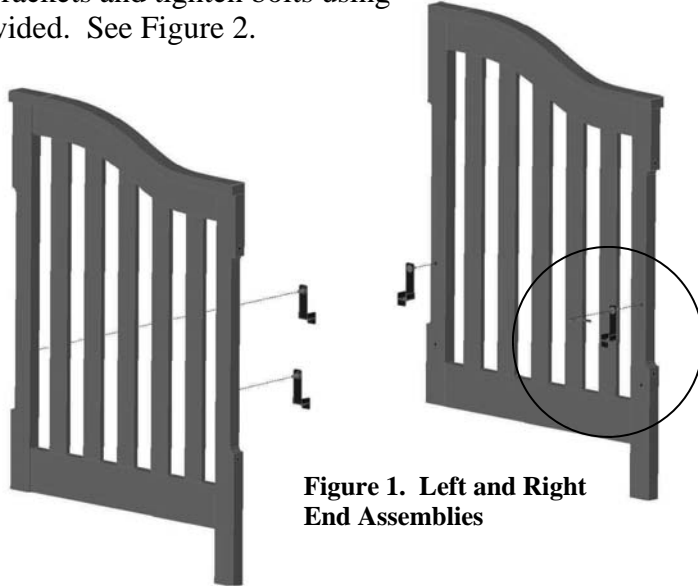

Figure 1. Left and Right End Assemblies

Figure 2.

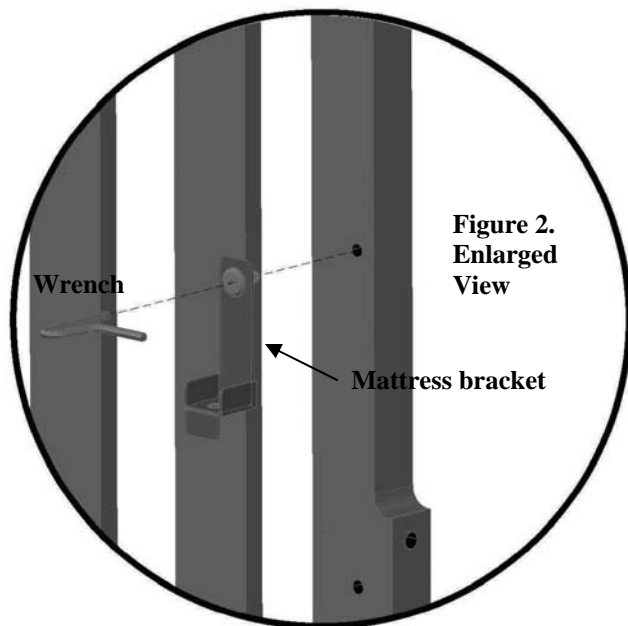

Figure 2. Enlarged View

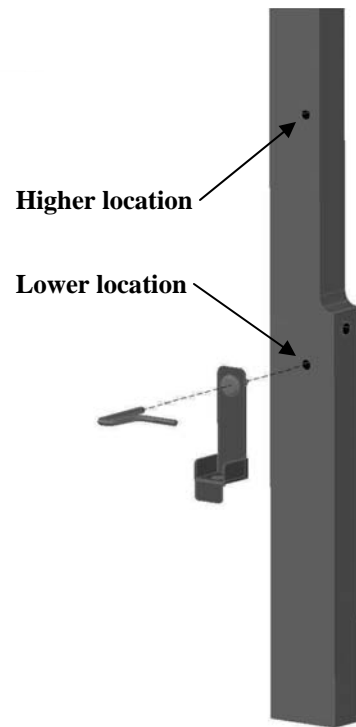

Figure 3.

Attaching the End Sections

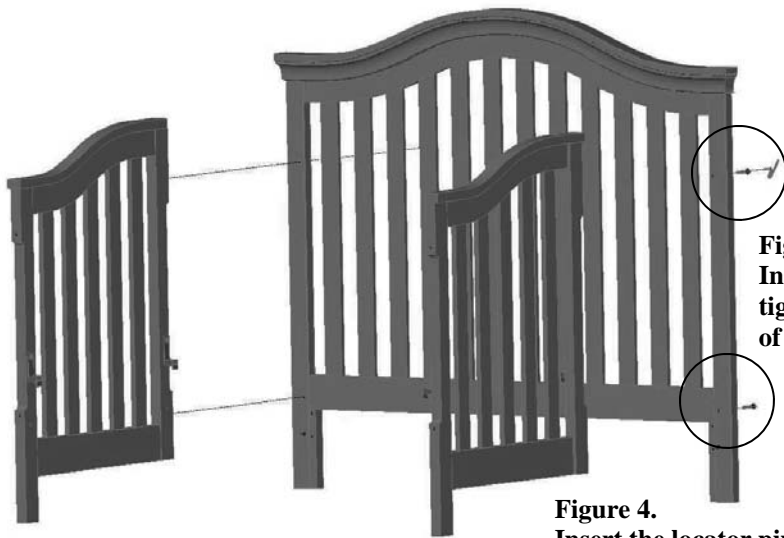

Figure 4.
Insert the locator pins

Figure 5.
Insert bolts and
tighten from back
of headboard

Step 2:

- Insert the (2) metal locator pins in the lower hole of the head board post as shown in Fig 4a.
- Support the headboard and attach the end sections to the headboard one at a time. (install the end sections so that the mattress platform brackets are to the inside of the crib). See Fig 6.
- Using the (4) 2" headboard bolts in the hardware pack, attach the bolts from the back of the headboard and tighten with the provided wrench. See Fig 5.
- Repeat for the remaining End Section.

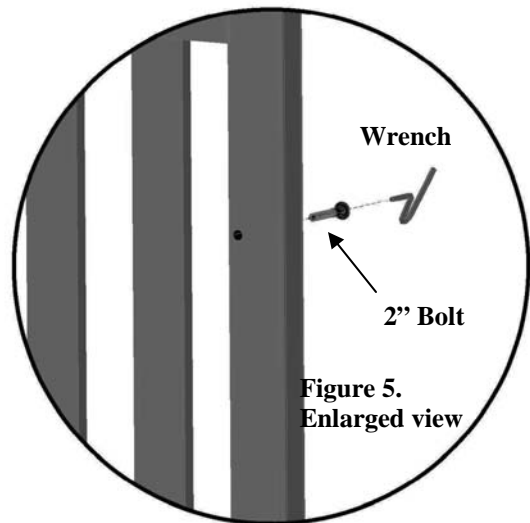
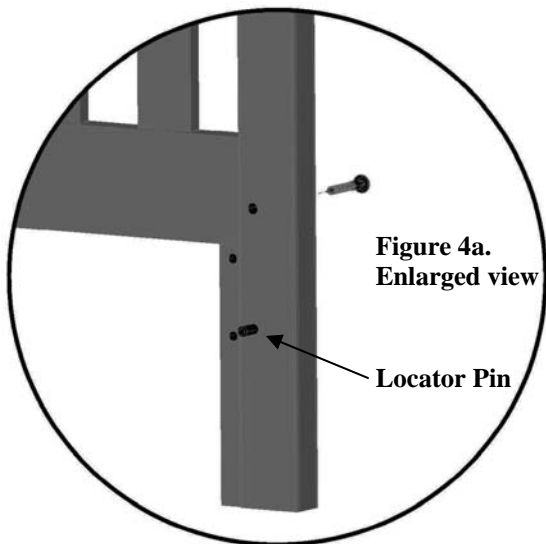

Figure 6.
Assembled ends to headboard

Attaching the Mattress Platform

Step 3:

- Place the Mattress Platform into the support brackets. (Before inserting bolts, make sure the instruction holder and the warning label are facing up and readable as shown in Fig 8.
- After the Mattress Platform is in place, use the (4) 2 3/8" connector bolts to attach the Mattress Platform to the support brackets. Insert each bolt in place and start the bolt into the bracket threads. See Figure 7.
- After all bolts have been set, securely tighten each bolt to complete the mattress platform assembly.
- Fig. 8 is how your crib should look with Warning labels facing the front of the crib.

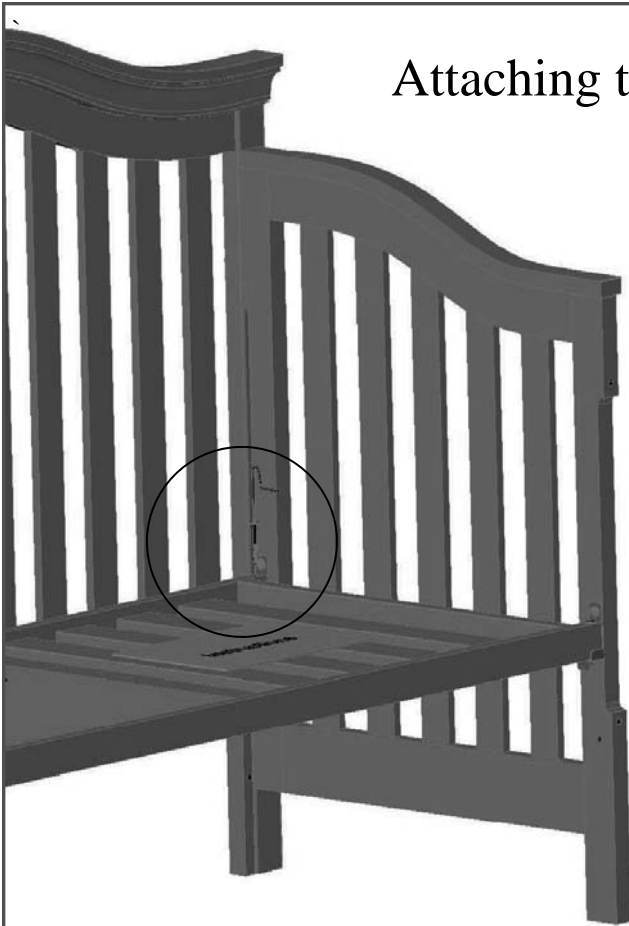

Figure 7.
Enlarged view of bolt attachment

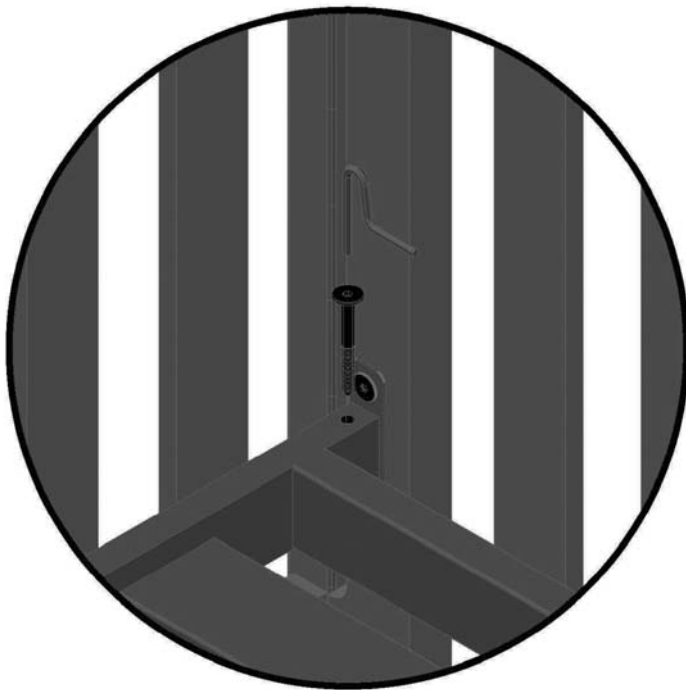

Figure 8.
Assembled with mattress platform

Attaching the Footboard



Figure 9.
Attach the footboard

Step 4:

- Align the footboard with the end sections.
- Using (4) $2\frac{3}{8}$ " connector bolts, loosely attach the footboard as indicated in Fig 9.
- After the bolts have been attached, use the wrench provided to tighten each of the bolts to secure the footboard.

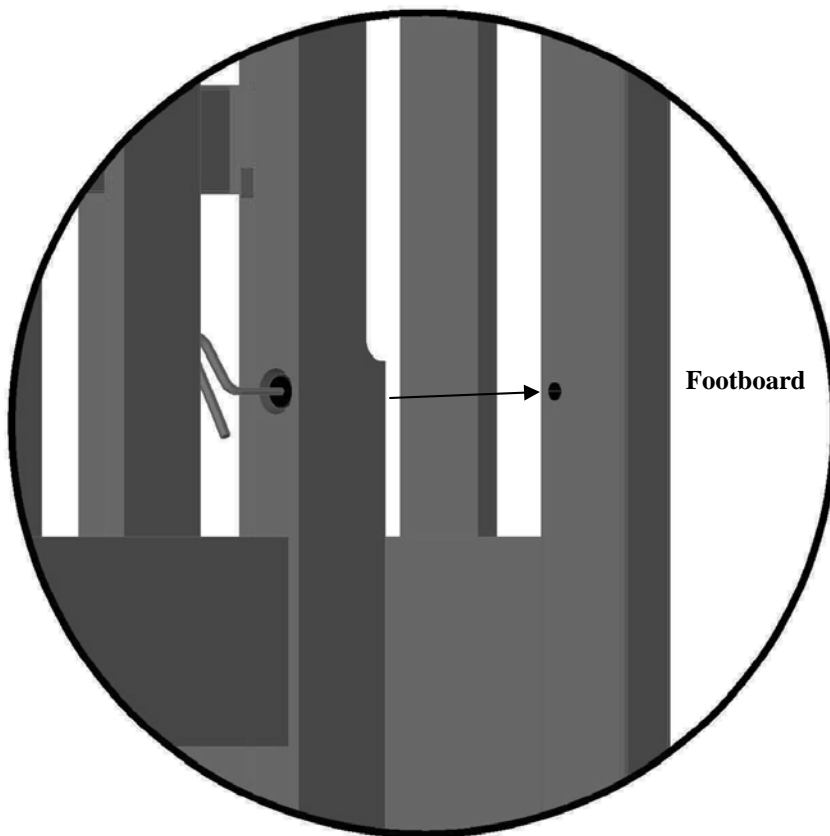

Figure 9.
Enlarged view of
bolt attachment

Final Step in Crib Assembly



Step 5: (The final and most important) Checklist.

- Inspect the crib once again to assure that all bolts are tight and that no hardware is missing. (if you have missing hardware, contact Stanley Furniture immediately for replacement and do not use the crib until the new hardware arrives).
- Do not place the crib near a window where the child may have access to window coverings, cords or draperies as these articles pose a strangulation hazard.
- Replace the instructions in the holder provided. **KEEP THE INSTRUCTIONS WITH THE CRIB.**
- Install the crib mattress.
- Follow all the warnings on the use of this crib and all products in the crib.

- **CAUTION:** Any mattress used in this crib must be at least 27-1/4" by 51-5/8" with a thickness of no less than 4 inches and not exceeding 6 inches.

Cleaning:

Mix together a mild solution of gentle dishwashing liquid and water, apply to the crib surface using a soft clean cloth lightly dampened in the solution. Rinse with clear water again using a soft clean cloth, then dry all surfaces thoroughly with a dry cloth. **NO ABRASIVE CLEANERS, SCOURING PADS, STEEL WOOL OR COURSE RAGS SHOULD BE USED TO CLEAN THIS FINE FURNITURE.**

Storage:

A permanent storage pouch is attached to the mattress platform for the storage of the assembly instructions. After completing the assembly process, you are advised to read and be aware of all **WARNINGS, CAUTIONS, CLEANING, STORAGE, USE AND MAINTENANCE** notices contained in these instructions. Do not place excess hardware in the storage pouch as it could present a danger to a child if retrieved and could also damage the mattress. When storing the crib, use **CAUTION** as temperature changes and humidity could be harmful to the crib. It is recommended that the crib be stored in a temperature controlled environment.

Periodic Maintenance:

1. Periodically check to make sure all bolts and connections are fastened securely.
2. If you are missing a part or need a replacement part, do not substitute parts. Ask your dealer for replacement parts or contact Customer Service at (800) 659-7297.
3. The crib allows for 2 mattress heights. Move to the low position when the child can pull up to a standing position. When the child reaches a height of 35” or can climb out of the crib you should place the child in a youth or regular bed.
4. Save these instructions in the event you disassemble the crib and need to reassemble it. These instructions will also be useful in identifying replacement parts if needed at a future date.

Lowering the Mattress Platform

Steps to lower the mattress:

- Remove the mattress from the crib
- Loosen the (4) bolts attaching the footboard and remove the footboard. See Figure 12.
- Loosen the (4) bolts attaching the Mattress Platform and remove the platform from the crib. Note the bolts will stay with the Mattress Platform. See Figure 13.
- Remove the platform brackets and place in the lower position. See Figure 14.
- Follow Steps 3, 4 and 5 on Pages 8, 9, and 10 to reassemble the crib.



Figure 12.
Enlarged view
of Footboard
removal

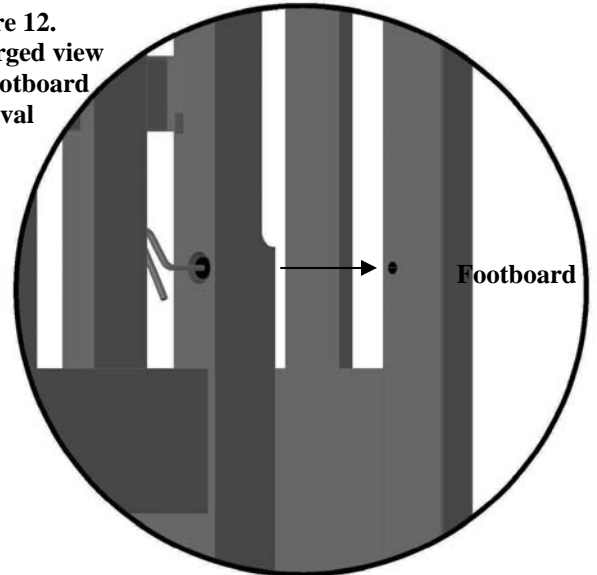

Figure 13.

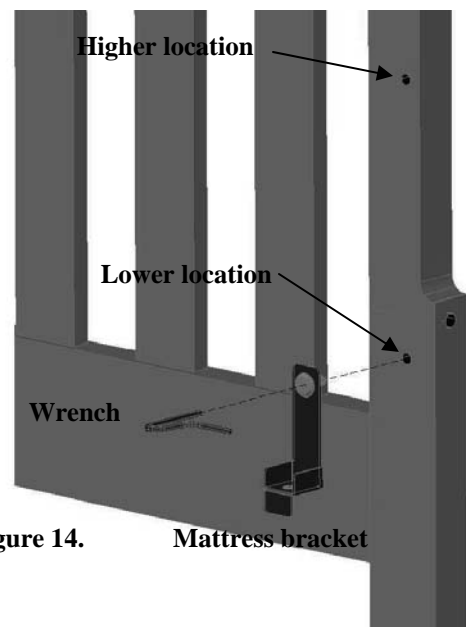
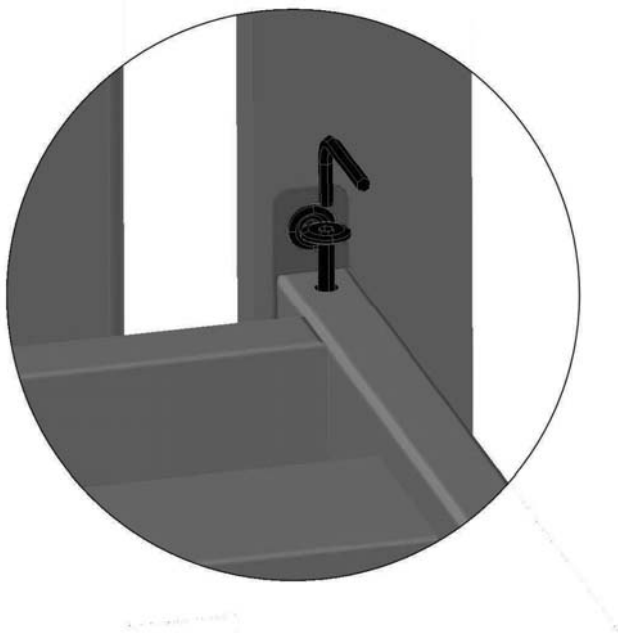

Figure 14. Mattress bracket

Converting Your Crib to a Daybed

Steps to Convert Crib to a Daybed:

Step A:

- The mattress should be in the low position. Follow the instructions on page 12 for lowering the Mattress Platform. Do not reattach the footboard.

Step B:

- Remove the (4) Bolts located in the End Frames: Locate the (4) 2 3/8" Inch Bolts using the illustration below. For each bolt, gently apply pressure to the exposed threaded end of Bolt. This will engage the threads of the Bolt with the Retainer Sleeve. With pressure being applied, insert the provided Allen Wrench into the opposite end and turn counter-clockwise.



Fully assembled Daybed

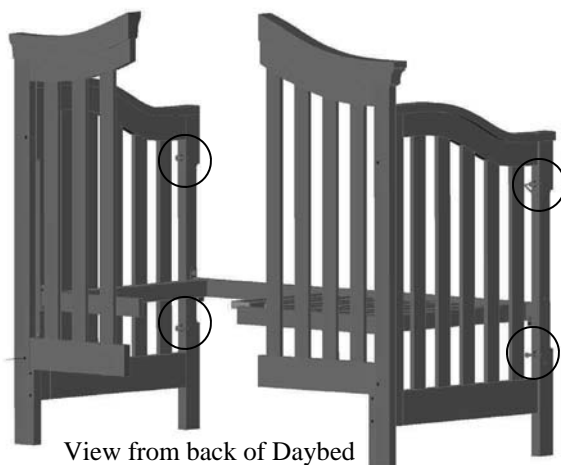

View from back of Daybed

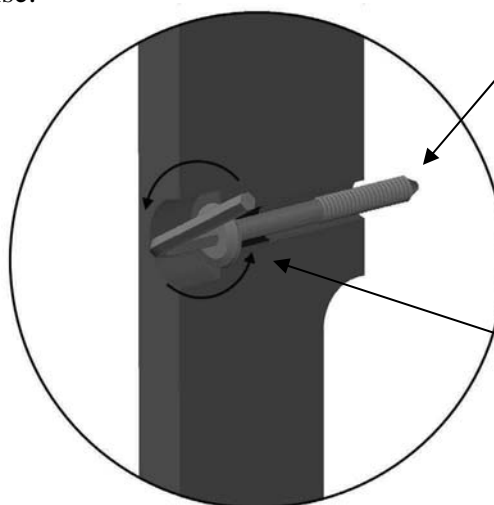

Push to Gently Apply pressure to this end of Bolt.

Insert Allen Wrench and rotate counter-clockwise.

Step C:

- Install (4) 3/4" Inch Bolts into the countersink holes where the 2 3/8" Inch Bolts were removed in Step B. Insert the 3/4" Inch Bolts into the countersink holes. Using the provided Allen Wrench while gently applying pressure, turn the Bolt in a clockwise motion. As the Bolt threads engage into the Bolt Retainer sleeve, gently tighten until the Bolt seats with the Retainer Sleeve (See illustrations below). **Note: Do not apply excessive force as the Bolt seats.**

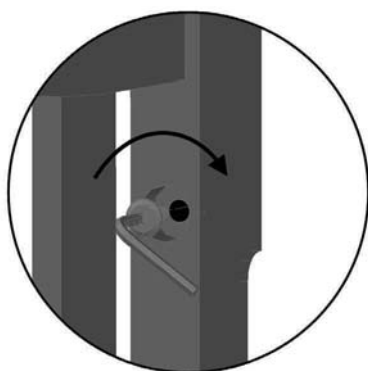

Installing Bolt

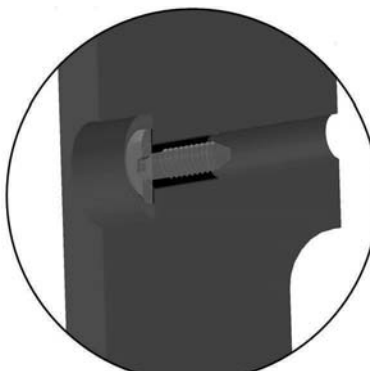

Bolt properly seated

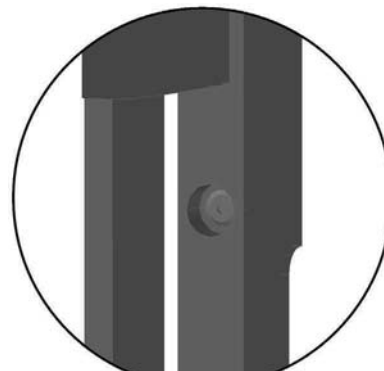

Installed Bolt

Accessories and Options

Toddler Bed Conversion Kit item BTK-3230

is available as an option to convert the Built to Grow Crib to a toddler or day bed. Contact your youngAmerica dealer to purchase this item.



Conversion to a Full Size Bed Kit BTF-3235 is available. Instructions to convert the Built to Grow crib are on the following page. Contact your YoungAmerica retailer, our Customer Service Center or website to purchase these items.



Safety Rails for a Full Size Bed item PSR-3268 are available for added safety when the bed is converted to a full size bed. Contact your YoungAmerica retailer, our Customer Service Center or website to purchase these items.



Converting to a Full Size Bed

Step 1: Disassemble the crib or toddler/day bed.

- Using the wrench provided remove the components in the following order:
- Remove the footboard
- Remove the mattress platform
- Remove the crib ends from the crib headboard
- Keep and store all the hardware for future assembly of the crib. Store the crib components in a safe dry place to prevent damage.

Step 2: Attach the side rails and slat roll.

- The side rails can be installed in two positions. The lower position, along with the purchase of Safety Rails, is recommended for transition from the crib to a child's first full size bed. The bed side rails can be moved to the upper position after your child adapts to the transition. Under bed storage options can be used with the bed rails positioned in the upper location. Contact your **youngAmerica** dealer for more information on available options.
- Install the rails into the headboard and foot board as shown and press down to lock into position.
- Remove (4) bolts from headboard. Note: The factory-installed Bolt Retainer Sleeve in the posts may give resistance. The bolts require unthreading from back side of headboard.
- Insert (2) 1" connector bolts and 3/4" caps in the headboard and (4) 3/4" connector bolts in the footboard to cover the crib assembly holes. Tighten with the wrench provided. See Figure 15.
- Install the slat roll using the instructions provided with the slat roll for proper installation.

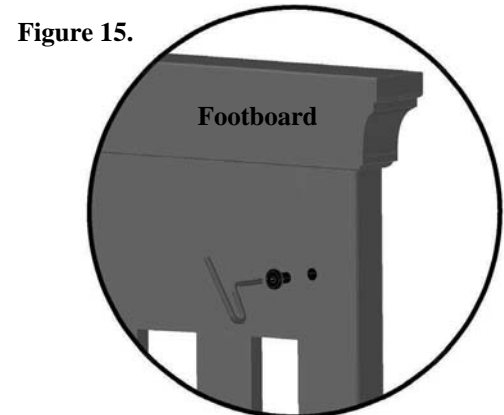
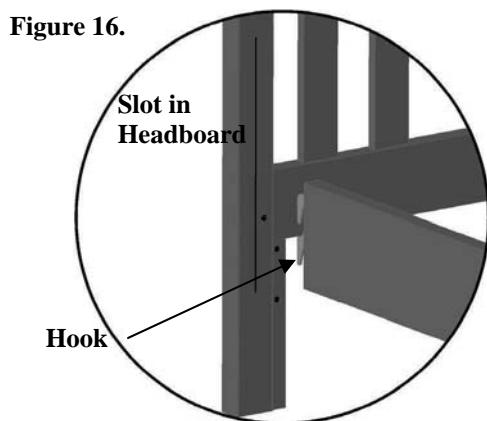
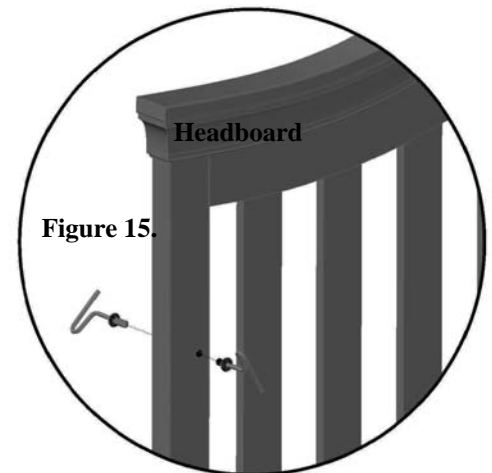
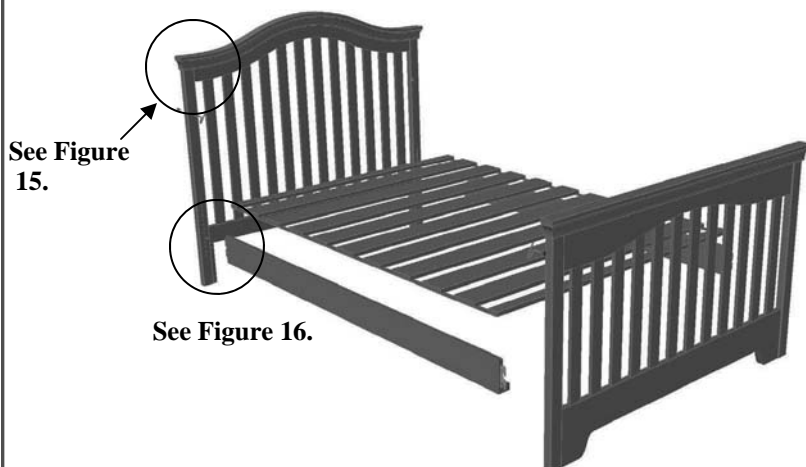

Stanley

Furniture

Young America
Stanley Furniture Company
200 North Hamilton Street
High Point, NC 27260

For questions or parts, contact your Young America retailer or our Customer
Service Center: 800-659-7297 Mon.-Fri. 8am-5pm, Sat 9am-3pm EST
www.youngamerica.com