

SS98NF • 15" Marine Crescent Ice Maker • Marine Series

FEATURES & BENEFITS



STAINLESS
SOLID
(NO FLANGE)

PERFORMANCE	<ul style="list-style-type: none"> • Uses less than 3 gallons (11,4 litres) of water to produce up to 25 lb (11,3 kg) of ice per day • Up to 25 lb (11,3 kg) in ice storage capacity • Crescent ice cube dimensions: 1/2" W x 3/4" H x 2 1/4" L (12,7 mm W x 19 mm H x 57 mm L) • On/Off switch is conveniently located on the grille • Available in 115 or 220-240 volts
INTERIOR/EXTERIOR	<ul style="list-style-type: none"> • No drain required • Door swing is field reversible • Standard travel package includes door latch, ensuring safe-at-sea storage • Corrosion and UV resistant components provide product longevity in harsh environments
INTEGRATION	<ul style="list-style-type: none"> • Unit is designed to be built-in or can be freestanding • Accepts a 1/4" (6,4 mm) custom insert panel

MODEL DETAILS

Model	Voltage/Hz	Door Swing	Finish	Shipping Weight
ULN-SS98NF-03A	115 / 60	Field Reversible (No Flange)	Stainless Solid	74 lb (34 kg)
ULN-SS98NF-20A	220-240 / 50	Field Reversible (No Flange)	Stainless Solid	73 lb (33 kg)

ACCESSORIES

Model	Description	Finish	Shipping Weight
80-54674-00	Braided water supply line kit	N/A	2 lb (0,9 kg)

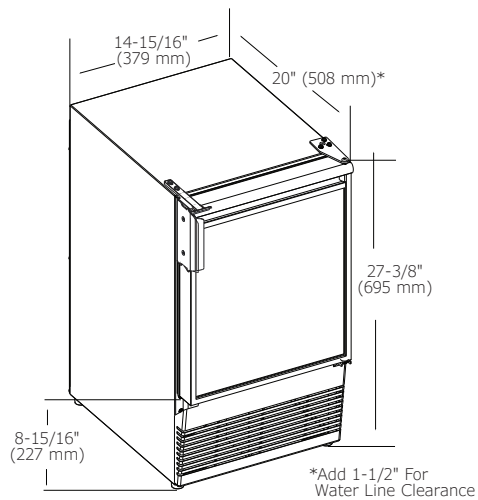
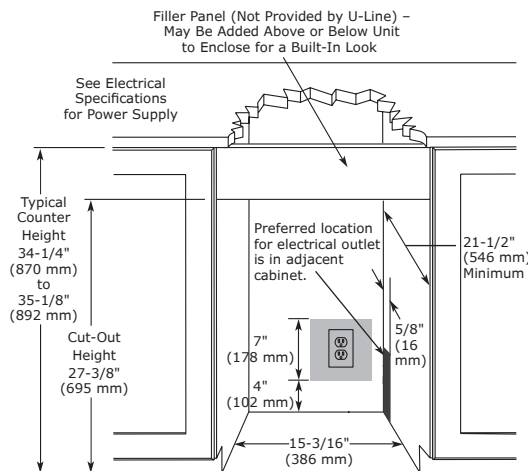
Marine Series • 15" Marine Crescent Ice Maker • SS98NF
DIMENSIONS

CABINET CUT-OUT

INSTALLATION NOTES

No additional clearance around sides, top or rear of unit is needed for ventilation.

Do not obstruct front grille air flow.

SPECIFICATIONS

Model	SS98NF
Amps: Running (115v)	2.5 amps
Amps: Running (220-240v)	1.2 amps
Amps: Max Start Up (115v)	18 amps
Amps: Max Start Up (220-240v)	6 amps
Control Type	On/Off Switch
Defrost Type	Manual
Dimensions: Product Depth	20" (508 mm)
Dimensions: Product Height	27 3/8" (695 mm)
Dimensions: Product Width	14 15/16" (379 mm)
ENERGY STAR	N/A
Panel Type	Insert
Panel Thickness	1/4" (6,4 mm)
Panel Height	15 15/16" (405 mm)
Panel Width	13 15/16" (354 mm)
Ice Production Per Day	25 lb (11,3 kg)
Ice Storage	25 lb (11,3 kg)
Product Weight: Max	68 lb (30,8 kg)
Refrigerant Type	R134A
Sabbath (Star K Certified)	No



UL listing only applies to 115 v models.

CE only applies to 220-240v models.

Please visit U-Line.com to view this model's User Guide.

All specifications are subject to change without notice.