

**VERTICAL WINDLASSES
4000 SERIES**

© Copyright: VETUS-Maxwell APAC Ltd.

All rights reserved

VETUS-Maxwell APAC Ltd. reserves the right to make engineering changes to all products without notice. Illustrations and specifications not binding as to detail.

P19159 Rev. 11.00

20/12/2016

Printed in New Zealand

Contents

1.0	INTRODUCTION.....	2
1.1	PRE-INSTALLATION NOTES.....	2
1.2	PRODUCT VARIATIONS.....	3
1.3	SPECIFICATIONS	4
2.0	INSTALLATION	6
2.1	SELECTION OF POSITION FOR THE WINDLASS	6
2.2	PREPARATION OF MOUNTING AREA	8
2.3	PREPARATION OF THE WINDLASS.....	8
2.4	INSTALLING THE WINDLASS	9
2.5	SELECTION OF MOTOR STARTER.....	11
2.6	POWER CONECTIONS TO AC MOTOR	12
2.7	POWER CONECTIONS TO DC MOTOR	12
2.8	POWER CONECTIONS TO HYDRAULIC MOTOR	13
2.9	INSTALLATION OF CONTROLS	13
2.10	NOTE TO BOAT BUILDER	14
3.0	USING THE WINDLASS.....	15
3.2	LOWERING THE ANCHOR UNDER POWER	15
3.3	RETRIEVING THE ANCHOR UNDER POWER.....	16
3.4	LOWERING THE ANCHOR UNDER MANUAL CONTROL	16
3.5	RETRIEVING THE ANCHOR UNDER MANUAL CONTROL.....	18
3.6	OPERATING THE WARPING DRUM INDEPENDENTLY.....	19
4.0	MAINTENANCE.....	20
4.1	WINDLASS MAINTENANCE.....	20
4.2	BAND BRAKE MAINTENANCE	21
4.3	RECOMMENDED LUBRICANTS	21
4.4	SPARE PARTS.....	22
4.5	TOOLS FOR MAINTENANCE.....	22
5.0	TROUBLESHOOTING.....	23
	APPENDIX A – Dimensional Drawings	25
	APPENDIX B – Spare Parts – Topworks	28
	Spare Parts – Bottomworks	30
	APPENDIX C – Installation Schematics	33

1.0 INTRODUCTION

1.1 PRE-INSTALLATION NOTES

- Read this manual thoroughly before installation and using the windlass. Failure to adhere to the correct procedures, recommendations and guidelines described in this Owner's Manual may invalidate the warranty.
- Be mindful that the correct selection of windlass for each application, together with correct installation, normal care in use and maintenance, are essential for long life and reliable performance.
- Inspect your windlass carefully when unpacked. Any damage or lack of components should be reported immediately to your Maxwell distributor.
- The windlass is supplied with chainwheel, as specified on purchase order. Make sure it is the appropriate one for the chain being used on board. Correct fit of the chain to chainwheel is essential for reliable and safe operation of the windlass. This can be guaranteed only when calibrated chain to a recognised international standard is used and the chain is correctly identified to Maxwell, or if a chain sample is provided to Maxwell to develop a custom chainwheel.
- The windlass is designed for use in conjunction with chain stopper and tensioner of the appropriate size. Their use is an important safety feature.
- For side pocket anchors, a chain roller should be installed above the hawse pipe to ensure smooth and quiet travel of the chain from deck to hawse pipe. The roller requires a central groove to align chain and flat faces (for longer chains) to support and avoid bending the chain links.
- The connection of the power lines and control circuitry to the windlass must be done by skilled technicians, to ensure reliable and safe operation of the windlass.

Note: For your nearest retailer, service agent or representative please refer to our website www.maxwellmarine.com

1.2 PRODUCT VARIATIONS

There are several options of above-deck arrangements or “topworks”, combined with three types of drives.

The types of topworks are:

- VWC - vertical windlass with chainpipe
- VWCLP - vertical windlass with chainpipe, low profile
- VW - vertical windlass

Each of the above topworks is available as clockwise or anticlockwise configuration (see description of Definition of rotation in Section 2.1).

Beside friction clutch, which can be used for controlling chain speed while free-falling anchor, the windlasses can also be equipped with an external band brake.

The types of drives are:

- Electric DC drive (24V)
- Electric AC drive (various voltages and frequencies)
- Hydraulic drive

For applications where deck is unusually thick, or is more convenient for drive to be positioned lower, Maxwell offers 2 extra deck clearance kits which will extend the drive by 75 or 225mm.

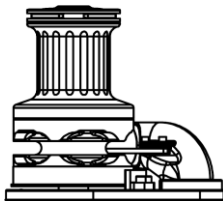

Picture 1.2
VWC Topworks

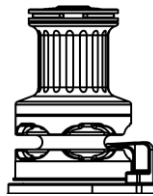

Picture 1.2
VW Topworks

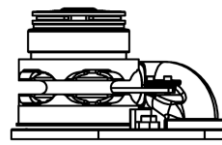

Picture 1.3
VWCLP Topworks

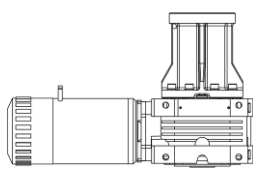

Picture 1.4
Picture Electric DC drive

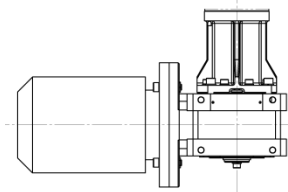

Picture 1.5
Electric AC drive

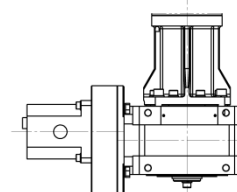

Picture 1.6
Hydraulic drive

1.3 SPECIFICATIONS

Note: Rated capacity and chain speed is based on the chainwheel for 10mm chain. The performance may vary by up to ±10% when other size chainwheels are used.

General	
Maximum stud link chain size	12.5mm (VW only)
Maximum short link chain size	14mm – VW 12.5mm – VWC VWCLP
Maximum pull capacity at chainwheel	1818kg (4000lb)

24V DC Drive	
Chain speed (at 200kg load)	15m/min (49ft/min)
Continuous pull capacity at chainwheel	420kg (925lb)
Current at continuous pull rating	80A
Motor power	2kW (2.7HP)
Weight of windlass	65kg (143lb)

AC Drive	
Chain speed (at 200kg load)	13m/min (44ft/min)
Continuous pull capacity at chainwheel	715kg (1753lb)
Current at continuous pull rating (@ 400V)	6.2A
Current at start up (@ 400V DOL)	41A
Motor power	3kW (4HP)
Weight of windlass	100kg (220lb)

Hydraulic Drive	
Chain speed (at recommended flow)	14 m/min (46 ft/min)
Recommended hydraulic oil flow	50 l/min (13.2 USgal/min)
Maximum hydraulic oil flow	61 l/min (17.7 USgal/min)
Continuous pull capacity at chainwheel	1818 kg (4000 lb)
Maximum hydraulic oil pressure	103.4 bar (1500psi)
Motor port size (pressure and return)	1 1/16" - 12 UN
Case drain port size	¼" BSP
Minimum size of oil supply/return lines	20mm (3/4")
Minimum size of case drain line	6mm (1/4")
Weight of windlass	47kg (104lb)

Hydraulic oil characteristics

Viscosity:

ISO 32 - 68 (at 20°C)

Suitable oils:

Shell Rimula X 15W-40

Shell Myrina M 15W-40

Penzoil SAE 10W-40

Texaco 2109 SAE 15W

Texaco 1814 SAE 10W-40

BP HLPHM 32-68

BP Autrans T0410

Castrol Hyspin AWS 32-68

Chainwheels

The chainwheel numbers consist of two parts: main part number and suffix, for example 3182-001. The main part number refers to the type of chainwheel and the suffix refers to size and type of chain.

Please refer to your closest VETUS-Maxwell agent or distributor (Appendix D), who will select the correct replacement chainwheel for your chain.

2.0 INSTALLATION

2.1 SELECTION OF POSITION FOR THE WINDLASS

Windlasses of this size will often be installed in pairs, giving an emergency backup in the event of mechanical or electrical failure. In this case one of the windlasses will normally be retrieving anchor running clockwise and the other anticlockwise.

Position of the windlass should be selected together with positions of hawse pipe and spurling pipe.

The deckplate should be installed pointing with its narrower end in the direction of the incoming chain. That allows the chain to have maximum engagement with the chainwheel.

Allow the chain a straight run from the bow roller to the chainwheel with no more than a 2° deviation from horizontal (Picture 2.1).

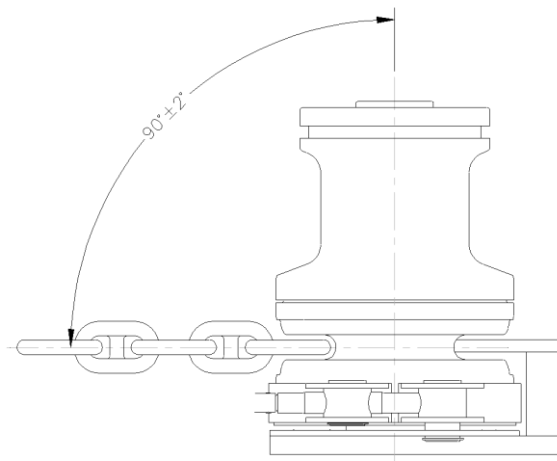

Picture 2.1
Direction of chain entering the Chain Wheel

The bow roller should have a vertical groove to suit the profile of the chain. Its centre line should be tangential to the chainwheel (Picture 2.2). This will align the chain so that it enters the chainwheel without twisting.

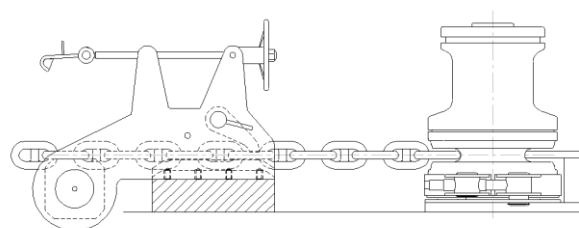

Picture 2.2
Correct height of Chain Stopper

When positioning the windlass, make sure that there is room to swing the clutch lever, so that it will clear the pulpit and life lines or bulwark.

The fitting of a chain stopper is essential to take the load off the windlass while the vessel is at anchor. It must be correctly aligned with the direction of chain and installed at appropriate height to avoid the chain rubbing over chain stopper body or pawl. Make sure the chain stopper clears the anchor stock.

A tensioner device to tension the anchor into its pocket is recommended. If the anchor is not snug in the pocket, it could cause damage to the pocket in a heavy seaway.

Ensure a minimum of 800mm (32") clearance between the end of spurling pipe and the chain piled up in the chain locker (Picture 2.3). This will assist kinks, which may develop in outgoing chain, to shake free.

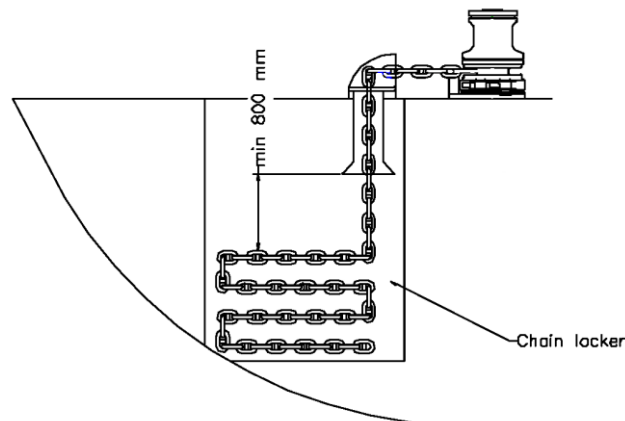

Picture 2.3
Recommended free space in chain locker

The chain must gravity feed into the locker. If the chainpipe cannot be positioned directly over the locker, a heavy wall pipe can be used to direct the chain to the required area. It is important that the chain slips through the pipe easily; completely unaided. Sharp corners should be avoided. It may be necessary to provide the pipe with a bell mouth or to bell mouth the entrance to the chainpipe from the locker to assist the free flow of the chain from the locker.

The chain locker must be of such a size and shape that the chain will heap up and feed out naturally without fouling.

If it can be arranged, the chain locker bulkhead should pass between the chainpipe outlet in the deckplate and the gearbox. This will keep the gearbox, motor and power lines dry and away from flaying chain. Access for servicing from inside the cabin area can usually be arranged through a locker.

Note that the gearbox can be indexed through a number of different angles in relation to the windlass deckplate (Picture 2.4). Be sure to select the most convenient arrangement at installation and ensure incoming chain well clears the gearbox, motor and power supply lines.

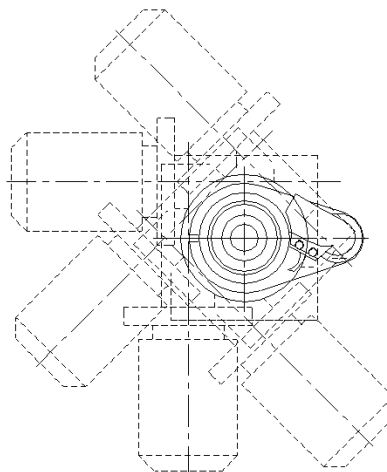

Picture 2.4
Positions of drive, relative to Topworks

To ensure safe position of the operator while tailing from the warping drum, footswitches should be positioned at least 500mm (20") away from the windlass.

The below deck portion of the footswitch should not be exposed to water or wet environment and the breather holes must be kept clear. The arrows on the footswitches should be arranged to indicate the direction of operation.

The motor starter (solenoid valves for hydraulic windlasses) should be located in a dry area in close proximity to the windlass. It must not be located in the wet environment of the chain locker.

The breaker/isolator panel (DC powered windlasses only) is selected to provide limited overload protection for the motor and full protection for the supply cables. It also provides the means for isolating the electrical system from the battery.

This should be mounted in a dry place within 1.8m (72") of cable length from battery.

This equipment or equivalent is mandatory to meet U.S.C.G. requirements.

2.2 PREPARATION OF MOUNTING AREA

It is of paramount importance that the vessel has sufficient deck reinforcing and total structural strength to sustain the loads that can be transmitted to the mounting area of the windlass and chain stopper. This should be equal to the loading of the equipment to beyond breaking strength of the chain.

The mounting area for the windlass must be perfectly flat and rigid. Structural grade fillers can be used to level this area if initial flatness is inadequate. Mounting area for the chain stopper should be prepared at the same time. The chain stopper has to be installed at an appropriate height to ensure that chain lays horizontally when it comes out of the chain stopper and into windlass. Maximum allowed angle deviation in vertical plane is $\pm 2^\circ$.

A deck cutout detail drawing is enclosed with these instructions to assist in marking out all the drilling and cutting required for installing the windlass. Before drilling and cutting, check the marked out area is dimensionally correct and make any necessary corrections.

The hole for mounting band brake guide (where applicable) should be marked and drilled after assembling the band brake on the windlass.

! Boats with steel/aluminium construction.

It is very important to insulate the deckplate from the boat with a non conductive gasket. Mounting studs and fixings under the deck should be insulated. Anchor and chain should also be insulated, including rubber lining, chain locker and fixing for the end of the chain to the hull.

Without these precautions severe electrolysis can occur. It is not necessary to separately earth the Windlass, as the electric motor is of the isolated earth type.

2.3 PREPARATION OF THE WINDLASS

Remove windlass from its packing case. Disassemble it in the following order (refer to drawing in Appendix B):

- Remove the cap (1) and o-ring (2) from the top of the windlass, taking care not to damage the chromed surface.
- Undo and remove the retaining screw (4) and retaining washer (5) under the cap, using a flat screw driver.
- Undo and remove clutch nut (6)
- For VW and VWC models only - remove drum (7)
- For extra drum height models only - remove spacer (8)
- Remove upper clutch cone (9) and disc spring (10).
- Undo screws (31) that retain chain stripper (33) and remove it.
- Remove chainwheel (11), disc spring (10), lower clutch cone (9), keys (18) and retaining clips (12).
- With non-band brake versions remove washer (13), spring (14) and emergency crank collar (15).
- Undo screws (16) and remove the deckplate (22).
- Refer to Appendix B of this Manual and identify all parts. If any parts are damaged or missing, contact your Maxwell distributor. Some smaller parts might not be assembled on the windlass by the factory, but supplied in a plastic bag in the packing case.

Maxwell strongly recommends generous application of a high quality anti-corrosive paste or coating to the mating sections of main shaft, drive key, flanges, screw threads, dowels and other surfaces that are likely to seize after being in contact for a prolonged period of time. Also ensure anti-corrosive coating is liberally applied to the inside wall of the spacer tube.

2.4 INSTALLING THE WINDLASS

Refer to the drawing in Appendix B for help with identifying components and installing them correctly. Extra care should be exercised when handling polished parts to avoid any damage to polished surfaces.

When assembling the parts, apply an anti-seize compound generously over all screw threads, keys and keyways, main shaft and inside the spacer tube.

Proceed with installation in the following order:

- After cutting holes for the windlass in the deck, apply an appropriate bedding/sealing compound and bolt the deckplate (22) to the deck using mounting studs (23), washers (24, 17) and nuts (25). Tighten them evenly to 35-40 Nm (25-30 ft lb). The chainpipe (33) and the pawl (28), if applicable, should already be assembled to the deckplate. (Picture 2.6 and 2.7)

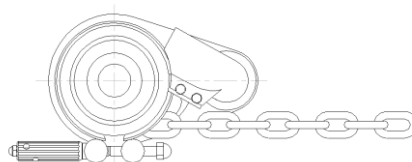

Picture 2.6
Clockwise Topworks

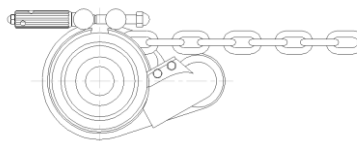

Picture 2.7
Anticlockwise Topworks

- Grease deck seal (38) and main shaft (41), offer up, from below deck, the drive assembly sliding the mainshaft through the deckplate, taking care not to damage the deck bearing.
- After aligning them correctly, bolt the deckplate and spacer tube together, from above deck, using the Hex screws (16) and spring Washers (17). Tighten them evenly to 35-40 Nm (25-30 ft lb).
- Re-check that the position of the drive assembly is satisfactory and convenient for connecting power supply lines to the motor. Also, make sure that the drive is not in the way of chain coming into the locker.
- If a chain counter is used, its sensor should be fitted into the Ø15mm hole in the deckplate, currently covered with a plastic plug (20). Make sure the deck is drilled below for the sensor cable. See brochure supplied with chain counter for detailed assembly instructions.
- Slide the emergency crank collar (15) over the mainshaft and then the spring (14) then the washer (13) on top of it. For band brake models, the emergency crank collar, spring and washer are not required. (picture 2.8).

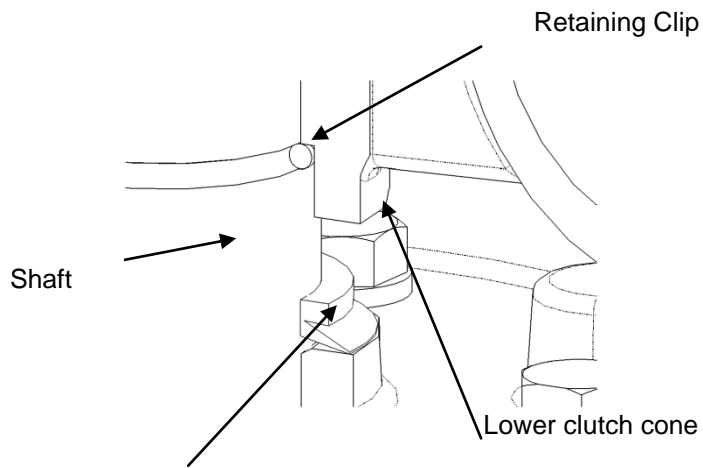

Seal (VW Band break versions only)

Picture 2.8
Clutch Cone / Retaining Clip / Seal Assembly

- Insert the two retaining clips (12) into the upper groove in the mainshaft; apply some grease to help keep them in position.
- Apply anti-seize compound generously over the mainshaft and keyway. Insert key(s) (18) into the keyway on the mainshaft.
- Assemble the lower clutch cone (9) making sure it sits nicely on the retaining clips (Picture 2.9). Apply lithium based marine grease generously to the conical surface of the clutch cone, to assist with free falling the anchor.

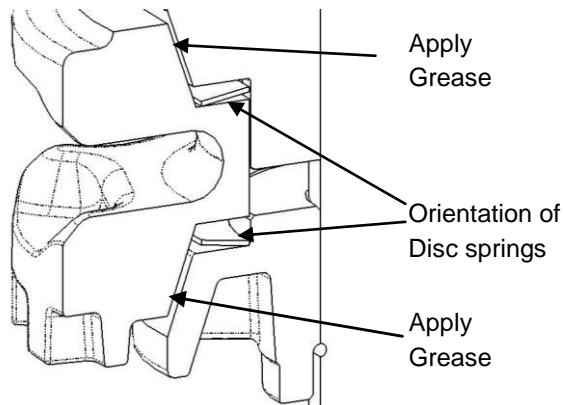

Picture 2.9
Greasing clutch cones and spring orientation.

- Put the disc spring (10) on top of the lower clutch cone (9) and install the chainwheel (11).
- Install band brake (if applicable) on the chainwheel, putting its fork over the pawl pin (30). The band brake can be assembled with its handle to either side of the windlass, choose more convenient option. (Picture 2.10)

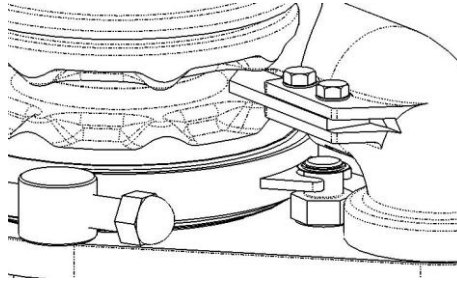

Picture 2.10
Band Brake Assembly

- Install upper clutch cone (9), after applying marine grease to its conical surface (see picture).
- For extra drum height models only – fit the spacer (8)
- Assemble drum (7) on top of the clutch cone (VW and VWC models only).
- Assemble clutch nut (6).
- Put retaining washer (5) on top of the mainshaft and secure it with the countersunk screw (4).
- Insert the cap (1) with o-ring (2) into the clutch nut.

! For effective operation of the band brake, the friction lining must remain free from contamination by any lubricant. Lithium complex base grease should, however, be applied to the lead screw thread.

! When installing the Windlass, the shaft MUST be coated in Shell Nautilus NLG12 Marine Grease, Castrol Boating Grease, Vavoline Val Plex EP or equivalent grease.

2.5 SELECTION OF MOTOR STARTER

Several AC motor starter options for windlasses are available, each with characteristic current demands and start load limitations. Maxwell recommends that selection of the best motor start system be entrusted to experienced persons familiar with anchoring procedures and the vessels generating capacity.

"Direct On Line" starter is the simplest way of starting an AC motor and it will allow the windlass to start under full rated load. However, this method requires relatively high momentary starting current, which the generators may have adverse effect to the rest of the electrical system on board. See specifications for current values at 400V in Section 1.3 and make sure to recalculate it for the voltage used on board. Start current may be limited to about half the above amount by using a "Star-Delta" starter. However, start torque is thereby limited to loads of about 25-30% of the windlass rated capacity.

"Star-delta" and "soft starters" are not recommended for starting windlass motors, as the motor torque is severely limited during start up period. Since these motors often have to start under load (when retrieving the ground tackle), they might not be able to move until they reach the full voltage and torque. The benefit of starting at lower current would therefore be lost. Also, the motor brake would release immediately on start-up, which could cause short movement of the chain in opposite direction.

The Variable Frequency Drives (VFD) offer accurate control of current during start up period while keeping high motor torque. They also offer various other benefits like:

- infinite speed control
- running the windlass over its nominal speed
- accurate current overload and thermal overload control

Both "Direct On Line" starters and Variable Frequency Drives are suitable and available from Maxwell, customised to suit the anchor windlass and stern capstan application.

! The selection of the type of motor starter should be done by a qualified electrical engineer, taking into consideration the power generating capacity on board. Maxwell offers both advice and different types of custom made starters to complement our windlasses.

! The “up” and “down” start contactors must be mechanically or electrically interlocked to safeguard the motor, in the event that an accidental attempt is made to start the motor in both directions simultaneously.

2.6 POWER CONNECTIONS TO AC MOTOR

Remove the motor terminal box cover and take care not to misplace the sealing gasket and screws.

Select a suitably sized, waterproof cable gland for the armoured supply cable. The selected gland fitting must fit the terminal box, be capable of anchoring the armoured cable, and allow an effective waterproof entry seal to be made.

Make the line connections to motor terminals. Make also an effective earth connection. Separately and similarly, enter the 2 thermistor cables to the motor terminal box, and connect to the two auxiliary terminal connectors of the thermistor circuit.

Check:

- Is the direction of rotation of the motor correct?
- Are cables satisfactorily fixed?
- Are cable entry points to motor terminal box satisfactorily waterproofed?

Spray the cable gland, cable entry points and motor terminal box with anti-corrosive waterproof coating "CRC 3013 Soft Seal" or equivalent.

2.7 POWER CONNECTIONS TO DC MOTOR

The main power system is a two cable, ungrounded, fully insulated, negative return system. The motor is of the isolated earth type. This system is selected to minimise electrolytic corrosion problems. The DC motor has four power terminals, marked “A1”, “A2”, “D1” & “D2”.

Terminal “D1” should be connected directly to “-” terminal on the battery, see wiring schematic in Appendix C.

Terminal “A1” should be connected to terminal “M2” on the starter (solenoid) box. When powered, the windlass should rotate clockwise.

Terminal “A2” should be connected to terminal “M1” on the starter (solenoid) box. When powered, the windlass should rotate anticlockwise.

See Table 2.1 to select the appropriate cable size for power supply. The recommendation assumes that the cable insulation has a minimum temperature rating of 90°C.

Cable lengths given are from the battery terminal to the terminal on the motor, via the solenoid box, and then back to the battery.

Where a portion of cable runs through the engine room, a size increase should be made as indicated. After connecting the cables, spray all terminals with anti-corrosive waterproof coating, “CRC 3013 Soft Seal” or equivalent

24v Systems				
Total Cable Length from battery to winch then back to battery	Wire Size		Engine Room Wire Size Correction*	
	mm ²	AWG	mm ²	AWG
Up to 18.3m (60')	22	4	25	3
From 18.3m – 30.6m (60' – 100')	50	1	-	-

2.8 POWER CONNECTIONS TO HYDRAULIC MOTOR

A basic hydraulic schematic is shown in Appendix C.

Port sizes on the hydraulic motor and minimum hose sizes are specified in Section 1.3.

The motor has pressure and return ports (bigger) and a case drain ports. The pressure and return ports should be connected to a solenoid controlled valve (not supplied by Maxwell).

After connecting the power lines, spray all ports and fittings with anti-corrosive waterproof coating, "CRC 3013 Soft Seal" or equivalent.

2.9 INSTALLATION OF CONTROLS

The windlass can be operated using:

- Deck mounted footswitches
- Hand held pendant controller (single or dual speed)
- Helm switch (single or dual speed)
- Chain counter

These control accessories are available from Maxwell customised to suit your windlass.

It is the choice of the designer/builder to use one, two or all three of these controls. They are wired in parallel to the directional valve (for hydraulic windlasses) or to the starter unit (for electric windlasses).

The controls can work on 12 or 24V power supply.

If footswitches are used, then an isolator switch for them must be installed in the wheelhouse, to prevent operating the windlass by someone accidentally stepping on the footswitch.

Hand held pendant controller is often the most convenient way of operating the windlass. Maxwell offers several variations of pendants, including single speed, dual speed, single pendant for running a pair of windlasses, pendants with auxiliary buttons which can be used for starting chain wash system, hydraulic pump etc. They are supplied with a plug on the other end of cable and a matching waterproof socket, which should be installed on a convenient location on the deck.

All units are supplied with detailed wiring instructions to assist installation.

Refer to wiring schematics in Appendix C for control circuits. All control wiring should be done using no smaller than 1.5mm² wire (AWG 16).

Where applicable, a manually re-settable, ignition proof 3A breaker or fuse should be installed on the power supply line for controls, within 1m (40") from the main breaker/isolator. These requirements are mandatory to meet USCG, ABYC and NMMA rules.

After connecting the power lines, spray all ports and fittings with anti-corrosive waterproof coating "CRC 3013 Soft Seal" or equivalent.



Picture 2.11
Hand Held Pendant Controller

2.10 NOTE TO BOAT BUILDER

Experience has shown that, on long ocean deliveries, sulphur from the ship's exhaust can settle on polished surfaces, which can affect the quality of the finish.

Please ensure that, upon completion of installation, the windlass is treated with suitable corrosion protective coating ("CRC 3097 Long Life") and wrapped in plastic film. This ensures that your customer receives the windlass from you in the same top quality condition as you received it from Maxwell.

3.0 USING THE WINDLASS

- As with all load carrying equipment, the consequences of heavy overload, neglect or misuse may be unexpected failure and exposure of crew and/or vessel to risk. Operate the windlass with extreme care at all times.
- Before testing the windlass for the first time, check that all the wiring has been done correctly.
- When using the windlass at all times practice good seamanship and adhere to the following rules in order to avoid any likelihood of injury or accident.
- At all times keep hands, feet, loose clothing, cordage and your hair WELL CLEAR.
- Never operate the windlass from a remote station without maintaining a clear view of it and having made sure that everyone is well clear of the windlass, anchor and chain.
- Never use the windlass under power with the clutch handle inserted into clutch nut or emergency crank collar.
- When engaging the pawl while chain is running, keep fingers away from the chain. Use clutch nut lever, underneath and guarded by the chainpipe.
- Always motor up to the anchor position before retrieving it from the bottom. Do not use the windlass to pull the boat to the anchor.
- If the anchor is fouled, do not use the windlass to break it out. With the chain stopper taking the load, use the boat's engine to break the anchor loose.
- When lowering the anchor under manual control, use the band brake or friction clutch (if fitted) to control the speed of the chain. Never lower the anchor without maintaining safe chain speed.
- When the windlass is not in use, make sure the power supply is isolated, making an accidental operation thereby impossible.
- Do not use the windlass as an anchoring point for the chain. Engage the chain stopper when the windlass is not in operation.
- Never proceed at speed without first ensuring that the chain stopper is engaged. Also engage the tensioner to keep the anchor snug in the pocket.
- When using the windlass, do not switch immediately from one direction of rotation to the other, without waiting for windlass to stop. Abuse is not covered by warranty.

3.2 LOWERING THE ANCHOR UNDER POWER

- Ensure the clutch is fully engaged by inserting the clutch nut lever in one of the slots on the clutch nut, and turning clockwise firmly. The windlass is equipped with a friction clutch, so it can be engaged in any position (there is no need to match the position of the opposite sides of the clutch before engaging it).
- Remove clutch handle.
- Release band brake or pawl (whichever is fitted).
- Disengage chain stopper and chain tensioner (if fitted). To disengage the chain stopper pawl the windlass may require momentary jogging in the up direction.
- The windlass may now be lowered under power by operating either the hand held pendant control, helm switch or footswitch.
- When finished, turn off the isolator switch for the controls.

! As a safety feature all buttons on the controls (pendant, toggle switch or footswitch) non-latching and the windlass will continue to operate up or down only while the switch is physically held in the engaged position.

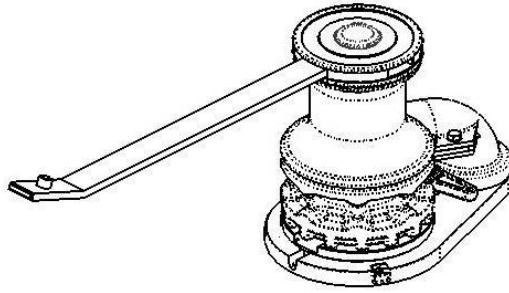

Picture 3.1
Engaging the clutch.

3.3 RETRIEVING THE ANCHOR UNDER POWER

- Ensure the clutch is engaged, as described above, and band brake or pawl is released.
- Remove clutch handle from the clutch nut.
- Release tensioner. If a pawl type chain stopper is used, it can be left ratcheting on the chain, so it will engage itself automatically when the windlass stops.
- The windlass may now be operated to raise the anchor.
- After retrieving the anchor, make sure the chain stopper and tensioner are engaged.
- Turn off the isolator switch for the controls.

! It is regarded as sound practice to motor over the anchor position and so reduce chain tension. This will also help the anchor to break out, reduce the power consumption and reduce load on the windlass and deck gear.

! Care should be exercised when docking the anchor to avoid damage to the anchor pocket. Jog in the last meter (3-4') of the chain carefully seating the anchor home.

3.4 LOWERING THE ANCHOR UNDER MANUAL CONTROL

This method will normally be employed to lower the anchor quickly, to lower it in "quiet ship" and in emergencies (power loss or control failure).

Proceed as follows:

- Tighten the clutch and band brake (if fitted).
- Release the chain stopper and chain tensioner. If the anchor has to be lowered in case of power loss and pawl on the chain stopper is engaged and under tension (by chain), to release it, pull the chain in slightly, using tensioner. Once the pawl is disengaged, release the tensioner and disengage it. If there is too much slack in the chain, it might be necessary to remove the domed nut from the end of lead screw and release the screw completely. If doing that, make sure the band brake and clutch is still engaged, for safety reasons (see Picture 3.2).

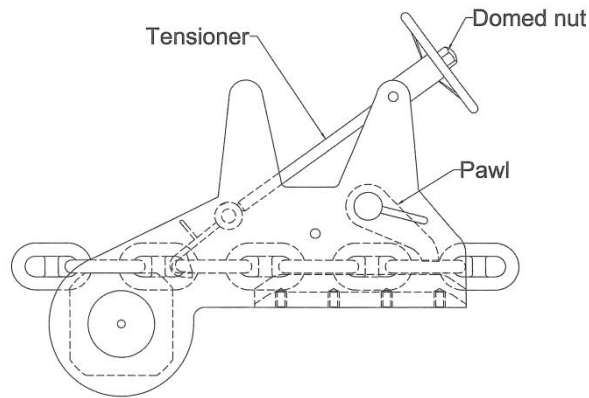

Picture 3.2
Chain roller-stopper-tensioner.

- Fully disengage the clutch by turning the clutch nut anticlockwise until it comes to a stop.
- Slowly release the band brake in a controlled manner. The chain should now release, the weight of self-launching anchor being sufficient to draw out the chain. Regulate the chain speed by gradually engaging/disengaging the band brake.
- When the required amount of chain is out, tighten the band brake and engage the chain stopper.
- If the band brake is not fitted, the speed of chain can be controlled by the clutch. In that case, after disengaging the chain stopper, slowly release the clutch by inserting the lever into the clutch nut and turning it anticlockwise. Regulate the chain speed by gradually engaging/disengaging the clutch.
- To apply more torque when engaging the band brake, the brake is equipped with a bar, which can be inserted into the brake handle as a lever (Picture 3.3). The bar is normally stored inside the handle.

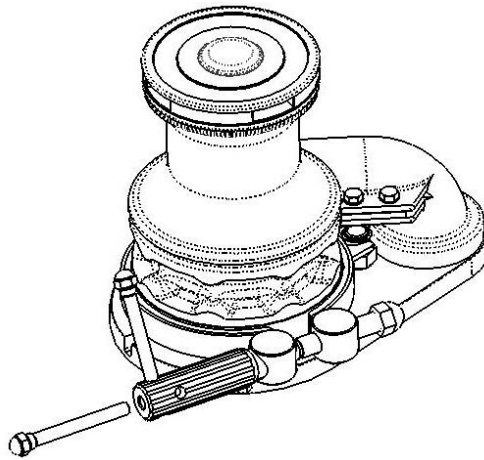

Picture 3.3
Using band brake lever.

! Chain roller-stopper-tensioner. It is considered potentially dangerous to allow the chain to free fall in an unrestricted manner -always control the chain speed.

3.5 RETRIEVING THE ANCHOR UNDER MANUAL CONTROL

The windlass (models without band brake only) is equipped with a cranking mechanism to retrieve the anchor in case of emergency. It involves operating the windlass manually under heavy load and extra care must be exercised when using it to avoid injury.

To use proceed as follows:

- Check that the chain stopper is engaged. If a chain stopper is not fitted, ensure that the pawl (28) is engaged with the chainwheel (11).
- Insert the clutch nut lever in the clutch nut and release clutch by turning the clutch nut in anticlockwise direction.
- Insert the clutch nut lever (the end with spigot) into the emergency crank collar (15) and engage the spigot with one of the dogs in the chainwheel in the furthest forward position (Picture 3.4).

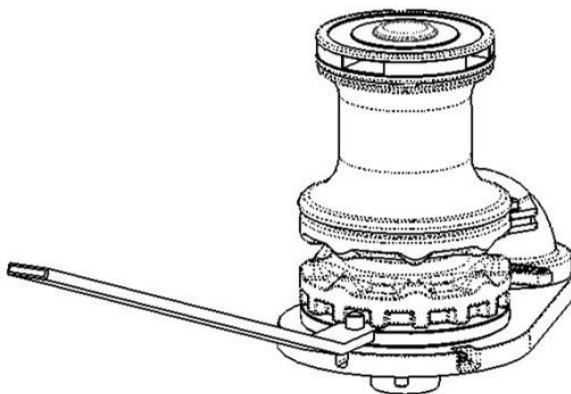

Picture 3.4
Emergency crank position.

- Pull the lever back as far as possible, bringing the chain in. Engage the pawl (28) and ease off the lever.
- Push lever to furthest forward position and re-engage with the chainwheel.

! Repeat the cycle until the anchor is retrieved. It is a very slow process and should be used only in emergencies.

! The chain slack between the tensioner and the windlass should be kept to less than the end travel of the tensioner. This allows for safe disengagement of the tensioner and transfer of load to the chainwheel.

3.6 OPERATING THE WARPING DRUM INDEPENDENTLY

This is applicable to VW and VWC models only. The drum can be operated independently of the chainwheel and can be used to manage docking lines or a second anchor. To use in this way, proceed as follows:

- Engage the chain stopper, the pawl or the band brake (whichever is fitted).
- Fully disengage the clutch as described in Section 3.4.

The drum may now be operated independently of the chainwheel. Maxwell recommends all warping operations be controlled by the footswitch. This makes it a one-person operation and offers better control of the capstan in case of emergency.

Take several turns of the warping line around the drum and pull on the rope tail with sufficient manual force to provide good grip of the line to the drum, whilst operating the footswitch. Make sure the drum is operated in the same direction as the line is wrapped around it.

Do not engage more turns on the drum than are necessary to accomplish the task. Whilst docking, wind and tide can impose sudden and excessive line tension. It is recommended to allow slipping to occur at the drum. This will protect the capstan, docking lines and vessel from damage.

! While handling docking lines with the capstan, ensure everyone stays well clear of the lines and the capstan.

! Take care not to allow “riding turns”. This is caused by the loaded line climbing on top of lower loaded coils on the drum. A riding turn can only be removed by paying the line out to the point where the riding turn is created.

4.0 MAINTENANCE

4.1 WINDLASS MAINTENANCE

Every Trip:

- The above deck parts should be washed down with fresh water.

Every 6 months:

- Disassemble the above deck components of the windlass (up to the deckplate) as described in Section 2.3.
- Clean all components and check for damage.
- Grease the components using lithium complex base, water proof grease.
- Clean chromed surfaces with a cloth, damp with kerosene. After cleaning spray them with "CRC 3037 Long Life" or alternatively, with "CRC 6-66" or "WD-40". Regular use of "CRC3097 Long Life" will assist in maintaining the bright chrome finish.
- Apply anti-seize compound on screw threads and keyways.
- Re-assemble in the reversed order.
- Split gearbox from the spacer tube. Clean and re-grease mating faces.
- Inspect the components below deck for corrosion, chipped paint etc, clean them and touch up the paint if necessary. Spray them for protection with "CRC 3013 Soft Seal".
- Spray fresh water into the drainage slot (see picture 4.1) of gear box to breakdown and flush away any build up of salt/debris, which may have accumulated.
- Check the electric power connections and spray them with "CRC 3013 Soft Seal" for protection.
- Check the oil level in gearbox and top up if necessary. (See Section 4.3).

Every 12 months:

- Service Motor. The motors can be detached safely, without draining oil from the gearbox. If removing the motor, spray its shaft with an anti-corrosion spray before reassembling.
- Split gearbox from the spacer tube. Clean and re-grease mating faces.

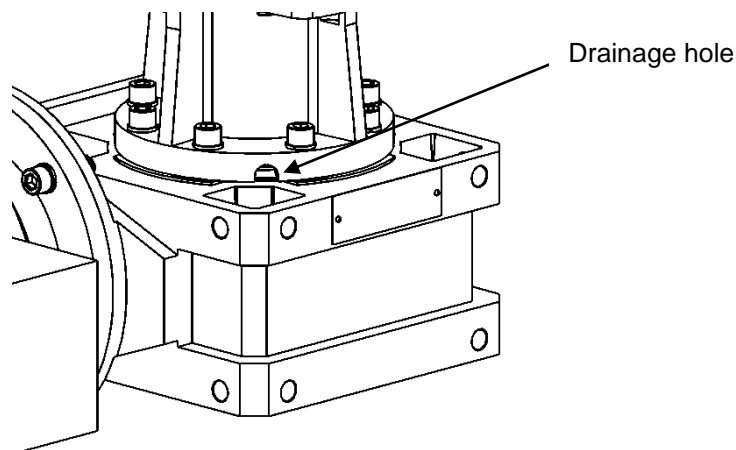

Picture 4.1
Spacer tube drainage hole

! Before doing any maintenance work on electric motor, starter units and wiring, make sure the power supply is switched off.

4.2 BAND BRAKE MAINTENANCE

The frequency of brake lining renewal will depend entirely on its usage. Should visual inspection reveal that the lining thickness has worn to below 2mm or if the ends of brake band can touch each other when tight, then it is necessary to renew the brake lining.

Grease the band brake lead screw at least every three months.

Avoid grease contamination of brake friction linings.

4.3 RECOMMENDED LUBRICANTS

Greases

Lithium complex base NLG1 consistency No. 2

- CASTROL LMX
- DUCKHAMS Keenol
- FINA CERAN WR 2
- SHELL Retinex LX
- MOBIL Mobilgrease HP

Gearbox Oils

ISO 3448 VG 320

- CASTROL Alpha MAX 320
- SHELL Tivela Oil
- MOBIL Mobilgear 632
- BP MACH GR XP 320

Quantity

AC, DC and Hydraulic drives : 0.9 litres

Anti-Corrosive Coatings

- CRC 3013 Soft Seal
- Boeshield T9
- Lanocote

Anti-Seize Coating

- International Paints Res-Q-Steel

! Never mix greases, use only one type. If in doubt, remove the previous lubricant and clean the parts thoroughly before applying the new one.

! Use synthetic oils only. Never mix two oils, even if they are from the same manufacturer.

4.4 SPARE PARTS

Maxwell recommends a modest quantity of spare parts to be ordered as familiarity with the windlass is developed during installation. As small parts can be lost during maintenance, keeping spares (and spare tools) is recommended.

We recommend the following list of spare parts per windlass to be carried on board:

Part No.	Description	Qty
P104750	Kit SS Cap and O_ring	
Includes:		
7191	Cap	1
SP2790	O-Ring	1
2311	Retaining clip	2
5953	Disc Spring	2
3150	Key (VW, VWC version only)	2
3207	Key (VWCLP version only)	1
4573	Gearbox Key	1
5198	Retaining washer	1
SP0466	Spring washer	1
SP0166	Cap Screw	1
7068*	Washer	1
2310*	Spring	1

* These items are not required with band brake versions.

If any other spare part is required, please refer to Appendix B for the correct part number and contact one of our distributors worldwide (Appendix D). When ordering spare parts, please quote:

- Windlass model
- Serial number of the windlass
- Part number (see Appendix B)
- Part description
- Quantity required

4.5 TOOLS FOR MAINTENANCE

We recommend the following tools be kept on board for disassembling and assembling the windlass:

- Set of metric hexagon keys (Allen keys), sizes 8 and 10mm
- Ring / open end spanner 17mm, 19mm 13mm and 9/16"
- Flat screwdriver 10mm blade width
- Circlip pliers

5.0 TROUBLESHOOTING

Problem	Possible Cause	Solution
Windlass does not rotate.	No electric power to controls.	<p>Make sure the isolator switch for the windlass controls is ON.</p> <p>Check the fuse on power supply to controls.</p> <p>Make sure the wiring is correct and check it for damage.</p> <p>If there is more than one type of control (pendant unit, footswitch, helm switch), check them all in an effort to isolate the problem</p> <p>Check isolator switch and fuse on Variable Frequency Motor Control, if supplied.</p> <p>Check the power supply to controls from the source, step by step, and identify the point where it stops.</p>
	Incorrect or incomplete wiring.	Check wiring against diagrams supplied.
	Damaged thermistors on the motor.	To confirm, check resistance across thermistors, it should be between 50 and 500 ohms. When doing that, do not use voltage.
	Faulty thermistor relay	To confirm, check resistance between terminals 21 and 22. If it is above 500 ohms, contact Maxwell.
	No power supply to the windlass.	<p>Check power supply lines.</p> <p>Check main isolator switch.</p> <p>Check hydraulic pump.</p>
Windlass is not able to pull the specified load.	Motor voltage does not match the power supply on board.	Check name plate on the motor. If confirmed, contact Maxwell.
	Hydraulic relief valve not set correctly.	Check valve setting.
Electric motor stops after prolonged heavy use.	The motor has been overloaded and has reached its maximum operating temperature.	Electric DC motors: Leave it to cool down and reset the circuit breaker.
		Electric AC motors: Leave it to cool down and thermistor relay will reset itself.
Windlass runs but the chainwheel stays stationary.	The clutch is not fully engaged.	Tighten the clutch up, as described in Section 3.2. If the problem persists, contact Maxwell.
	Band brake is engaged.	Release band brake.
	Topworks key(s) (18) not installed.	Install the key

The anchor does not free fall.	The clutch cones are not greased.	Disassemble the cones (9), clean and grease them as described in Section 2.4.
	The clutch is not fully disengaged.	Disengage the clutch fully.
	The band brake is not disengaged.	Disengage the band brake fully.
	Disc springs (10) not fitted.	Fit disc springs as described in 2.4.
	Pawl (28) engaged.	Disengage pawl.
Chain jumps / slips on the chainwheel.	The chainwheel not selected correctly.	Contact Maxwell with correct identification of the chain used on board.
	Chain twisted between windlass and bow roller.	Untwist the chain.
	Vertical angle of incoming chain bigger than 2 degrees (see Picture 2.1).	Check the installation. If the problem persists, some height adjustments might have to be made.

APPENDIX A – Dimensional Drawings

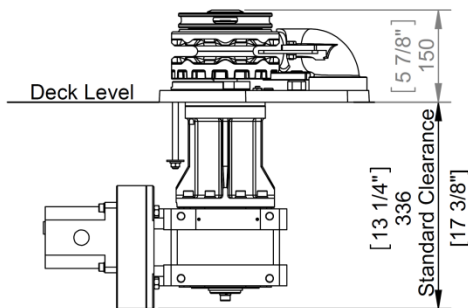
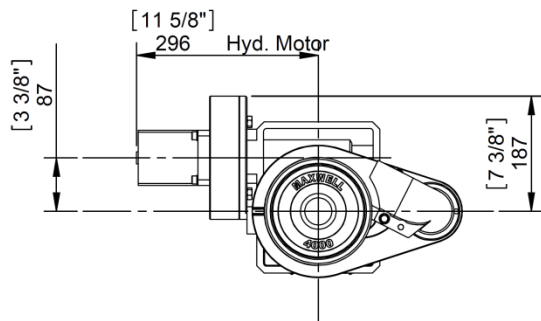
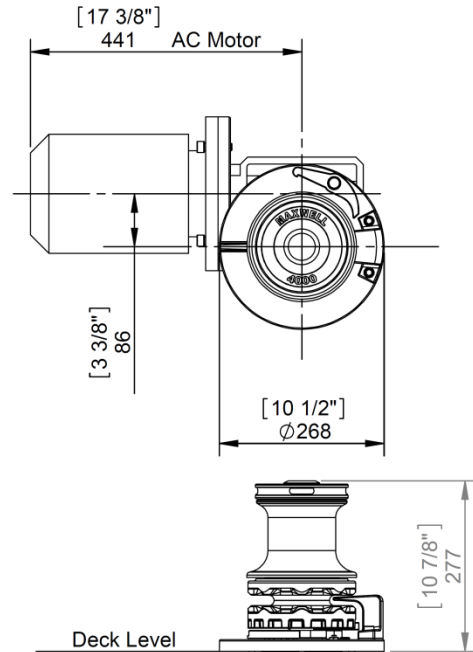
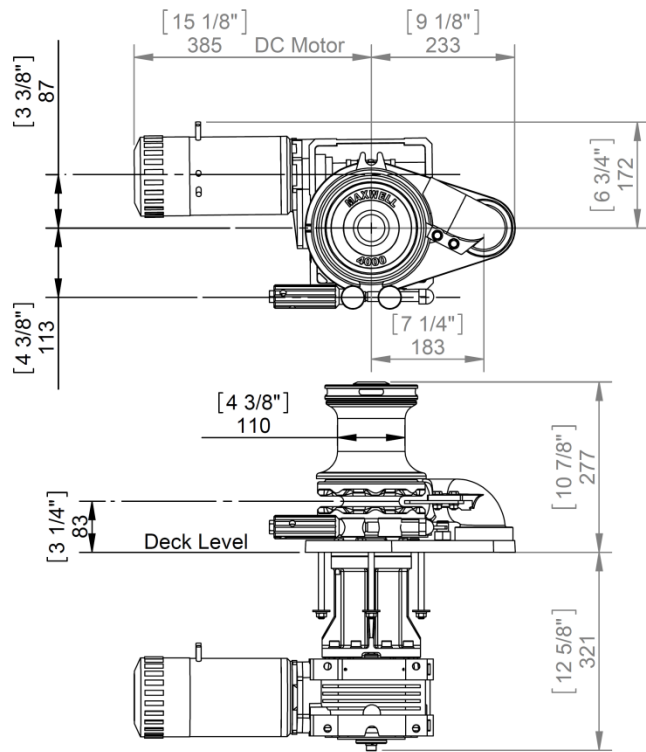

75mm Extra deck clearance
 [22 1/8"]
 561
 225 Extra Deck Clearance

Note:
 Dimensions are typical withing range.
 Each type of topworks, with or without band brake,
 can be combined with each type of drive.
 Use the deck level as a reference point to read
 dimensions for other combinations.

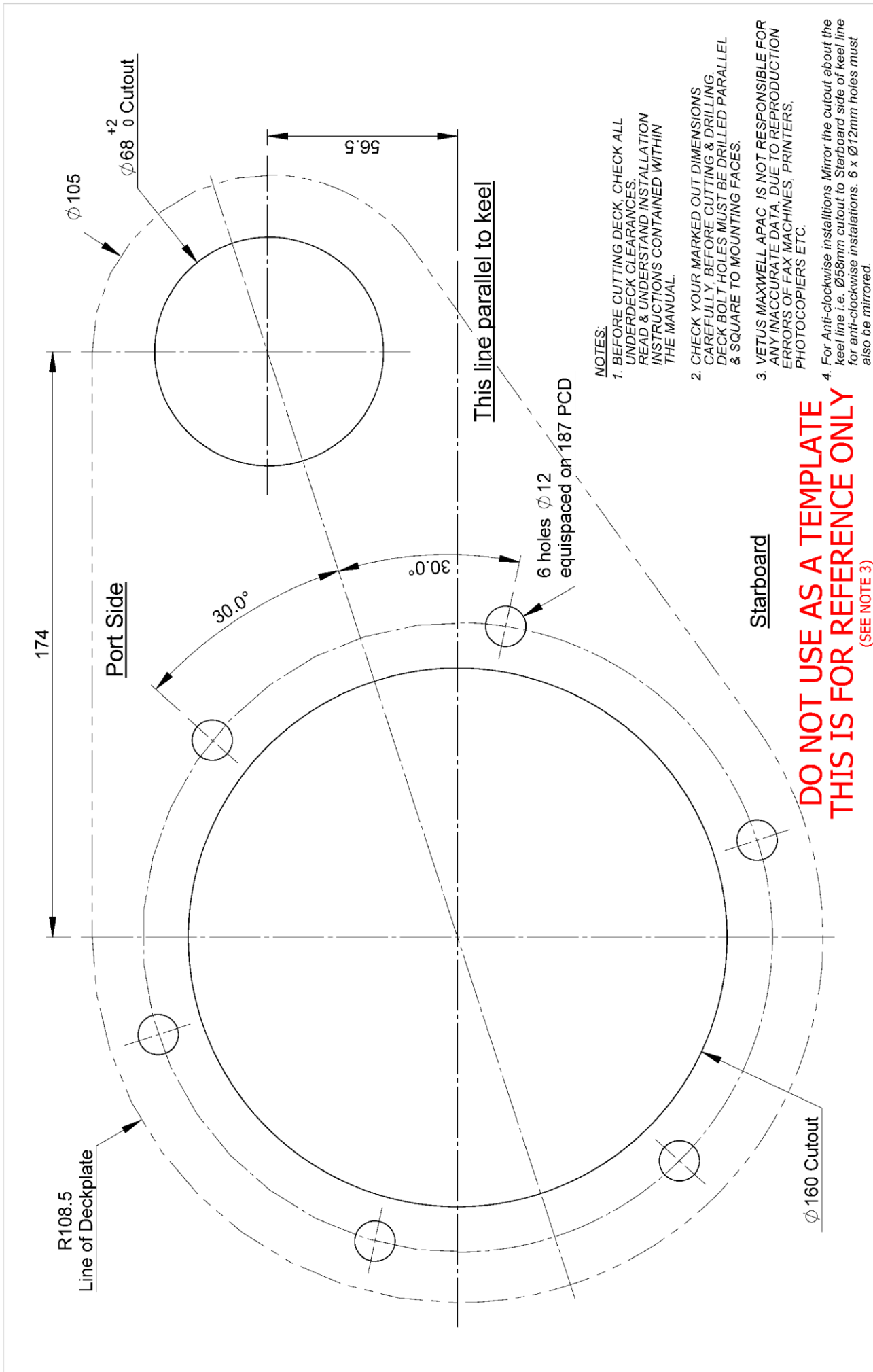

NOTES:

- BEFORE CUTTING DECK, CHECK ALL UNDERDECK CLEARANCES. READ & UNDERSTAND INSTALLATION INSTRUCTIONS CONTAINED WITHIN THE MANUAL.
- CHECK YOUR MARKED OUT DIMENSIONS CAREFULLY, BEFORE CUTTING & DRILLING DECK BOLT HOLES MUST BE DRILLED PARALLEL & SQUARE TO MOUNTING FACES.
- VETUS MAXWELL APAC IS NOT RESPONSIBLE FOR ANY INACCURATE DATA, DUE TO REPRODUCTION ERRORS OF FAX MACHINES, PRINTERS, PHOTOCOPIERS ETC.
- For Anti-clockwise installations Mirror the cutout about the keel line i.e. Ø58mm cutout to Starboard side of keel line for anti-clockwise installations. 6 x Ø12mm holes must also be mirrored.

**DO NOT USE AS A TEMPLATE
THIS IS FOR REFERENCE ONLY
(SEE NOTE 3)**

Revision	Issued in CAD	Change	Made on	Des/Drawn
6.00			29/06	RP
7.00	Template note added. Notes revised		29/06	RP
8.00	Main cutout hole changed from Ø132 to Ø160mm to suit stainless steel deckplate, sensor hole engulged		22/7/13	GB

Description:	
Deck Cutout Details - 3500 4000 VWCLP-VWC	Ordering No: 3338
Material: N/A	Revision No: 8.00
Tolerances if none specified	Sheet Size A3
0 DECIMAL (X) ±0.5	Scale N/A
1 DECIMAL (X.X) ±0.2	ALL ANGLES ±0.5°
2 DECIMAL (X.XX) ±0.1	

Revision	Sheet
1 of 1	1 of 1

This drawing is protected by copyright and the design and/or details contained therein are the confidential property of Maxwell Marine Ltd. This drawing must not be copied, loaned or have its contents communicated to any other persons, including subcontractors, without the consent in writing from Maxwell Marine Ltd. This drawing must not be used for any other purpose other than that for which it was originally supplied.

Rev.	Issued in cad	Change	Made on	Des/Drawn
2.00			8/3/06	RP
3.00	Template note added. Notes revised		29/3/06	RP

**DO NOT USE AS A TEMPLATE
THIS IS FOR REFERENCE ONLY
(SEE NOTE 3)**

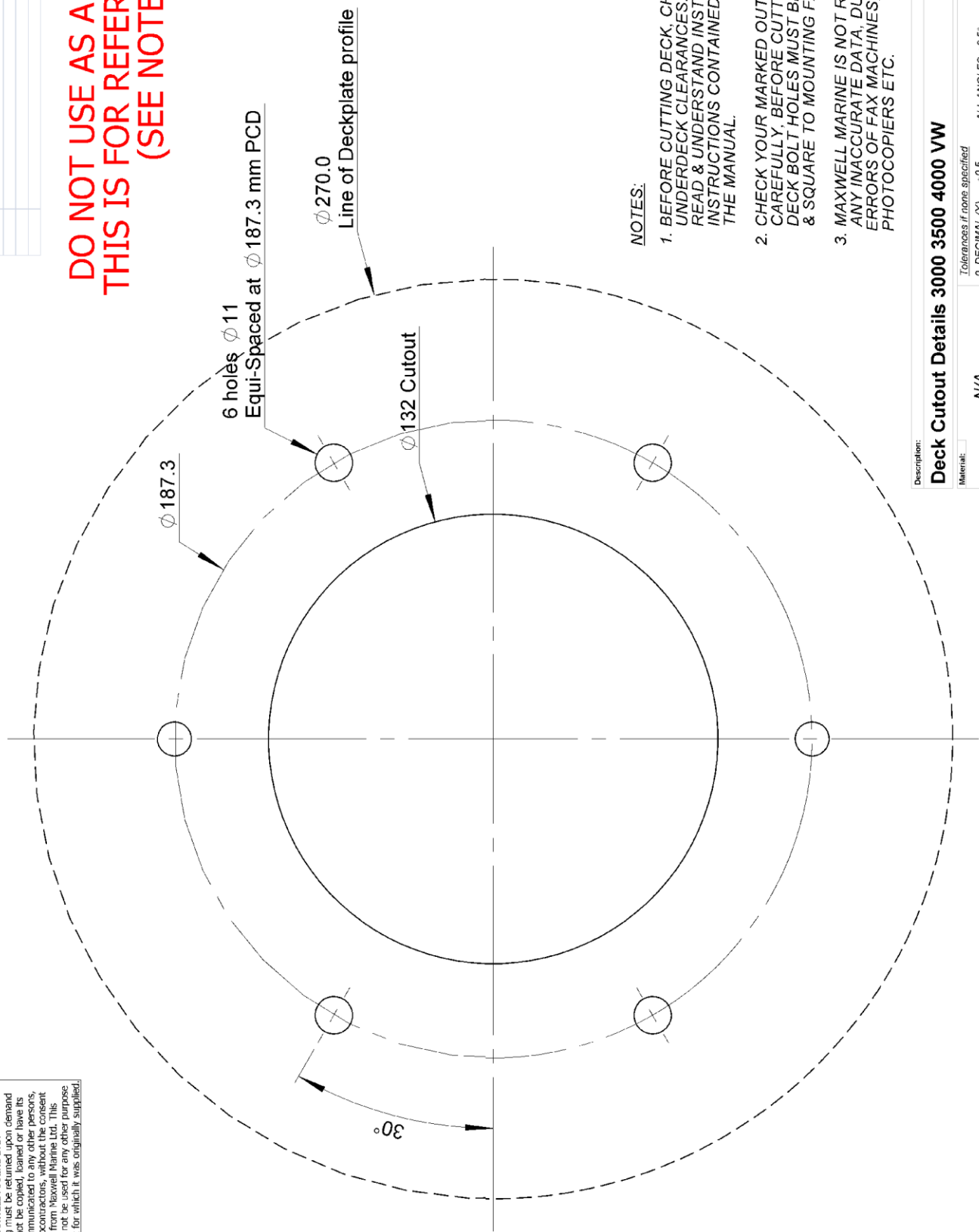

NOTES:

- BEFORE CUTTING DECK, CHECK ALL UNDERDECK CLEARANCES. READ & UNDERSTAND INSTALLATION INSTRUCTIONS CONTAINED WITHIN THE MANUAL.
- CHECK YOUR MARKED OUT DIMENSIONS. CAREFULLY, BEFORE CUTTING & DRILLING. DECK BOLT HOLES MUST BE DRILLED PARALLEL & SQUARE TO MOUNTING FACES.
- MAXWELL MARINE IS NOT RESPONSIBLE FOR ANY INACCURATE DATA. DUE TO REPRODUCTION ERRORS OF FAX MACHINES, PRINTERS, PHOTOCOPIERS ETC.

This drawing is protected by copyright, and the design and or details contained therein are the confidential property of MAXWELL MARINE LTD.
This drawing must be returned upon demand and must not be copied, loaned or have its contents communicated to any other persons, including subcontractors, without the consent in writing from Maxwell Marine Ltd. This drawing must not be used for any other purpose other than that for which it was originally supplied.

Description:		Revision No:	
Deck Cutout Details 3000 3500 4000 VW		4305	
Material:	N/A	Sheet Size	A3
Tolerances if none specified		Scale	N/A
0 DECIMAL (X) ±0.5		ALL ANGLES ±0.5°	
1 DECIMAL (X.X) ±0.2			
2 DECIMAL (X.XX) ±0.1			
		Revision No:	3.00
		Sheet	1 of 1



APPENDIX B – Spare Parts – Topworks

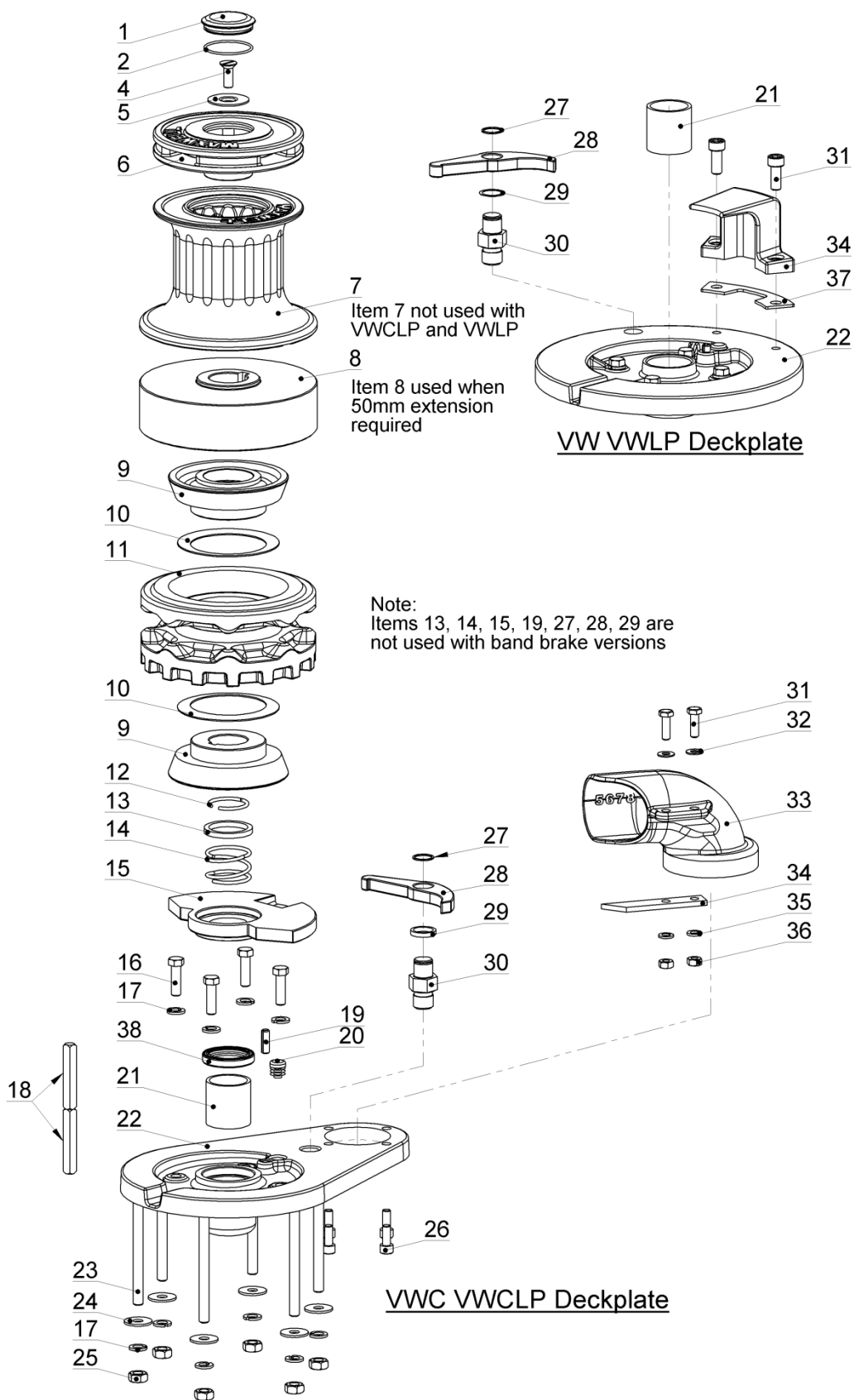

Item	Description	Qty	Part No.
1	Cap	1	7191
2	O-Ring	1	SP2790
4	Screw – Csk 3/8 x 1”	1	SP0040
5	Retaining Washer	1	3267
6	Clutch nut VWC, VW VWCLP, VWLP	1 1	5954 5675
7	Drum	1	8303
8	Spacer – with 50mm extension only	1	5185
9	Clutch cone	2	6061
10	Disc spring	2	5953
11	Chainwheel Non band brake version Band brake version	1 1	3182C 5437C
12	Retaining clip	2	2311
13	Washer – (Non band brake version only)	1	7068
14	Spring – (Non band brake version only)	1	2310
15	Emergency crank collar – (Non band brake version only)	1	3158
16	Hex Hd. Bolt – 3/8 x 1 ¼”	4	SP0287
17	Spring washer	10	SP0466
18	Keys – VWC, VW VWCLP, VWLP VWC – with 50mm extension only	2 1 3	3150 3207 3150
19	Pin – (Non band brake version only)	1	SP0544
20	Plug	1	SP0875
21	Bearing	1	SP0657
22	Deckplate VWC, VWCLP – Stainless Steel VW, VWLP - Chrome	1 1	5680 4279C
23	Stud – M10 100 TDC 175 TDC 325 TDC	6 6 6	5225 7482 7556
24	Washer – Flat	6	3843
25	Nut – M10	6	SP0371
26	Cap screws M8 x 20	4	SP0167
27	Retaining Ring	1	SP0871
28	Pawl	1	2324
29	Wavy washer	1	SP0463
30	Pawl Pin	1	3435
31	Cap screws M10 x 25 – VW, VWLP Hex. Hd Bolts M8 x 25 – VWC, VWCLP	2 2	SP0166 SP0288
32	Flat washers	2	SP0428
33	Chainpipe Clockwise configuration Anticlockwise configuration	1 1	5678 5804
34	Stripper VWC VWCLP VW	1 1	6980 4278C
35	Spring washer – M8	2	SP0467
36	Hex. Hd. Nut – M8	2	SP0366
37	Spacer – VW only	1	5671
38	Deck seal	1	SP2799

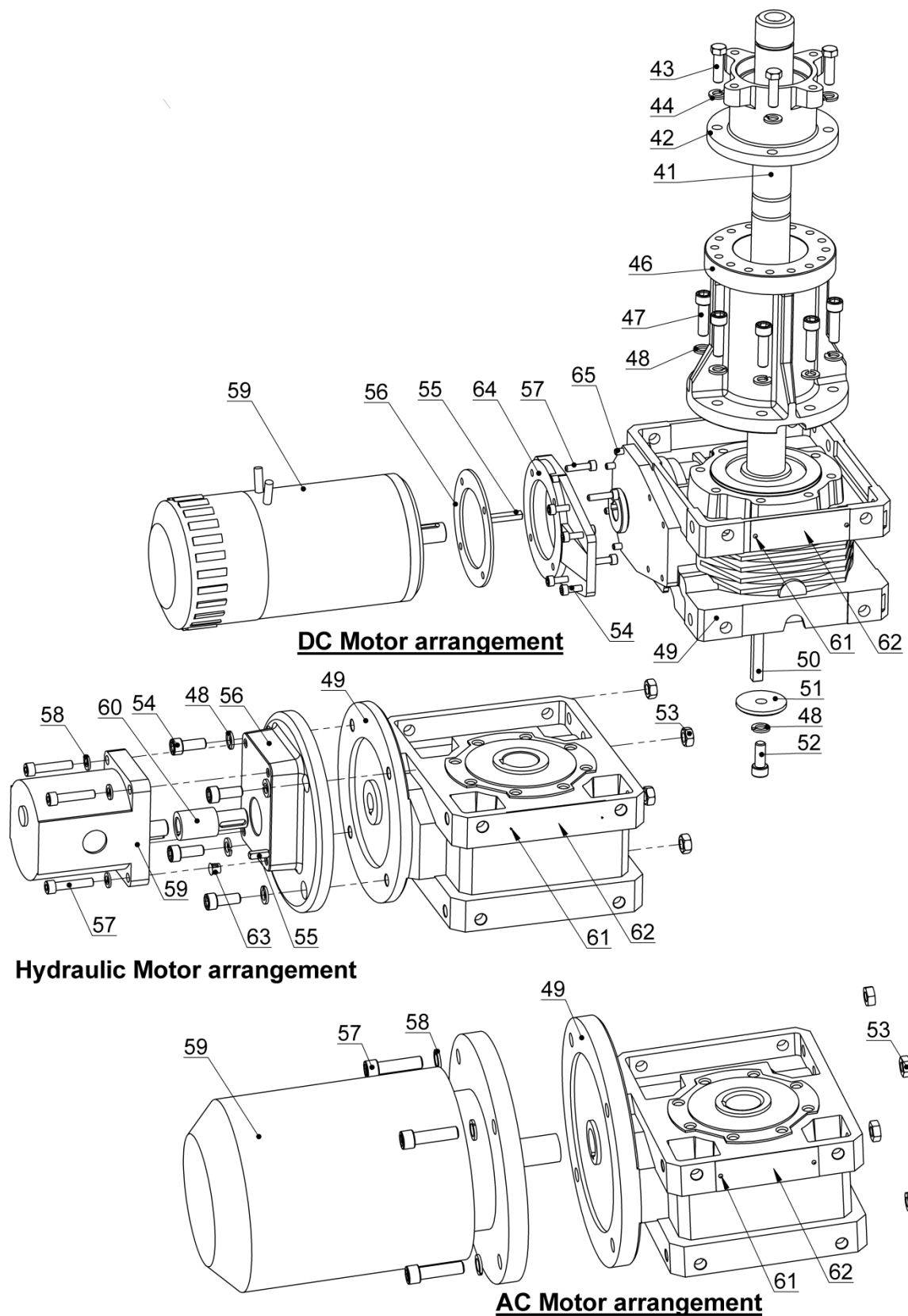

Item	Description	Qty	Part No.
41	Mainshaft		
	VWC 100TDC (Standard deck clearance)	1	4632
	VWC 175TDC (75mm extra deck clearance)	1	4980
	VWC 325TDC (225mm extra deck clearance)	1	4942
	VW	1	4632
	VWLP, VWCLP	1	4695
	VWC Standard deck clearance – 50mm spacer	1	5184
42	Spacer tube extension		
	175TDC (75mm extra deck clearance)	1	4824
	325TDC (225mm extra deck clearance)	1	4822
43	Bolts – with extra deck clearance only - 3/8" UNC x 1-1/4"	4	SP0287
44	Spring washers – with extra deck clearance only – M10	4	SP0457
46	Spacer tube	1	4570
47	Cap screws - M10 x 35	8	SP2451
48	Spring washers - M10		
	DC and AC Motors	9	SP0466
	Hydraulic Motors	13	SP0466
49	Gearbox		
	DC	1	SP5025
	Hydraulic Motors	1	SP2902
	AC Motors	1	SP3374
50	Key	1	4573
51	Retaining washer	1	5198
52	Cap screw - M10 x 25	1	SP0166
53	Hex. Hd. Nuts		
	M10 –Hydraulic Motors	1	SP0371
	M12 – AC Motor	1	SP2451
54	Cap screws		
	DC Motor – M6 x 16	4	SP0170
	Hydraulic motor – M10 x 25	4	SP0166
55	Key		
	DC Motors	1	4577
	Hydraulic Motors	1	4673
56	Adapter Plate		
	DC Motors	1	7942
	Hydraulic Motors	1	6942
57	Cap screws		
	DC Motors – M6x25	4	SP0175
	Hydraulic Motors - M8 x 40	4	SP0151
	AC Motors - M12 x 45	4	SP3206
58	Spring Washer		
	M8 - Hydraulic motor	4	SP0467
	M12 – AC motor	4	SP0475
59	Motor		
	Hydraulic	1	SP2250
	24V DC	1	SP5027
	220-400V 50HZ 3kW	1	SP2194
	208V 60HZ 3kW	1	SP2928
	480V 60HZ 3kW	1	SP2904
	440V 60Hz 3kW	1	SP5003
60	Coupling - (Hydraulic motor only)	1	6943
61	Hammer screws	2	SP0523
62	Serial label	1	5478
63	Plug	1	SP3519
64	Flange – (DC motor only)	1	SP5026
65	Cap screw M16 x 30	4	SP2459

Spare Parts – Band Brake

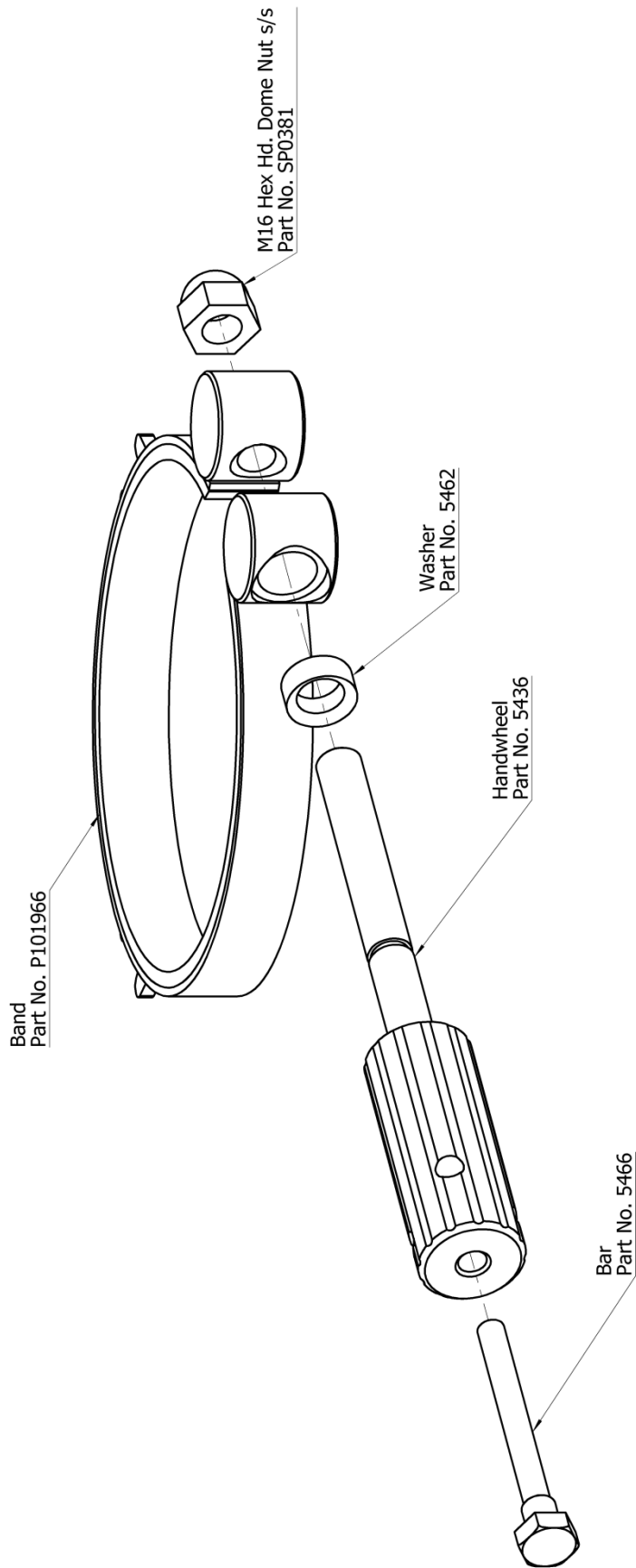

P101967 Band brake Assembly

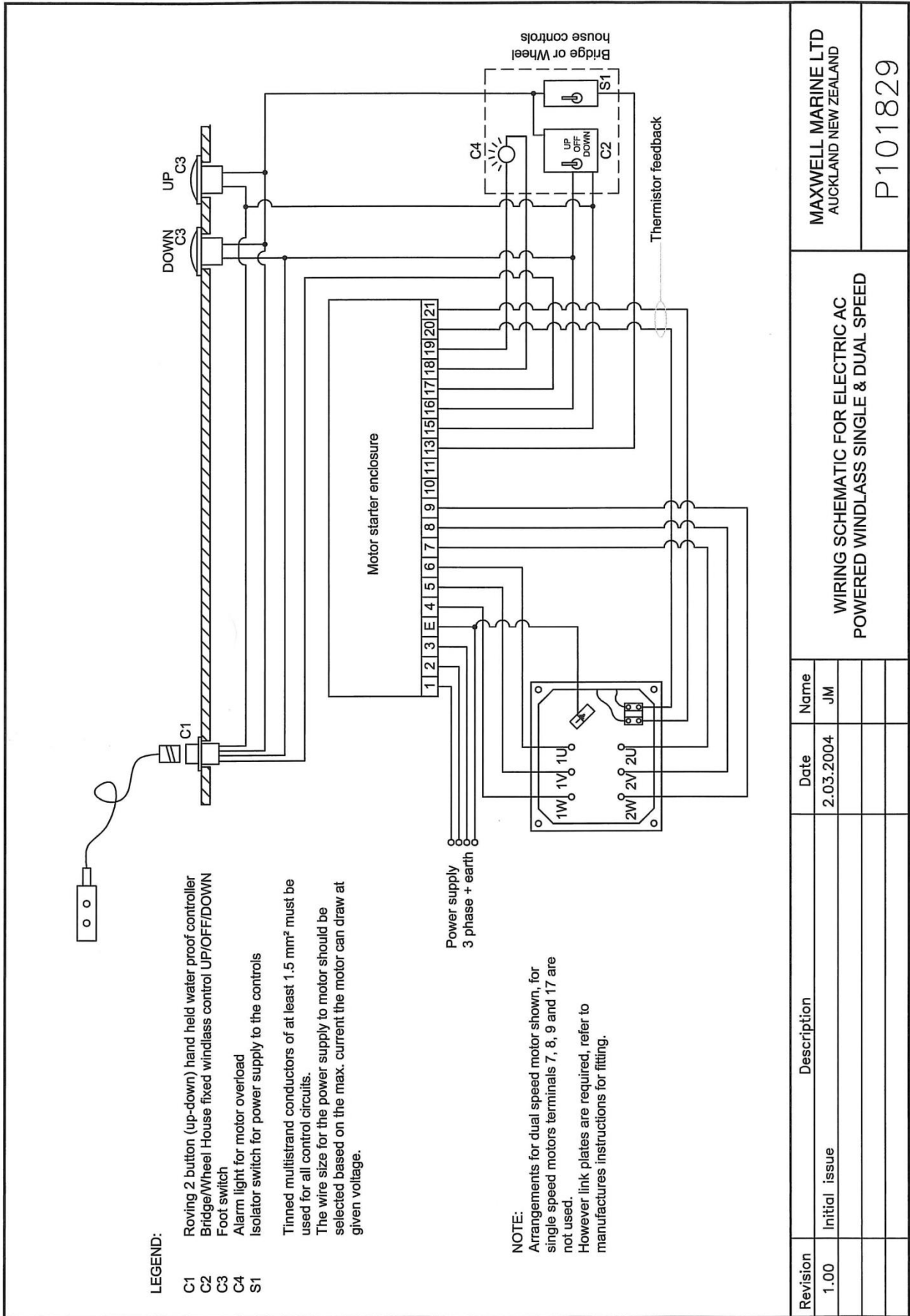

MAXWELL MARINE LTD
 AUCKLAND NEW ZEALAND

WIRING SCHEMATIC FOR ELECTRIC AC
 POWERED WINDLASS SINGLE & DUAL SPEED

P101829

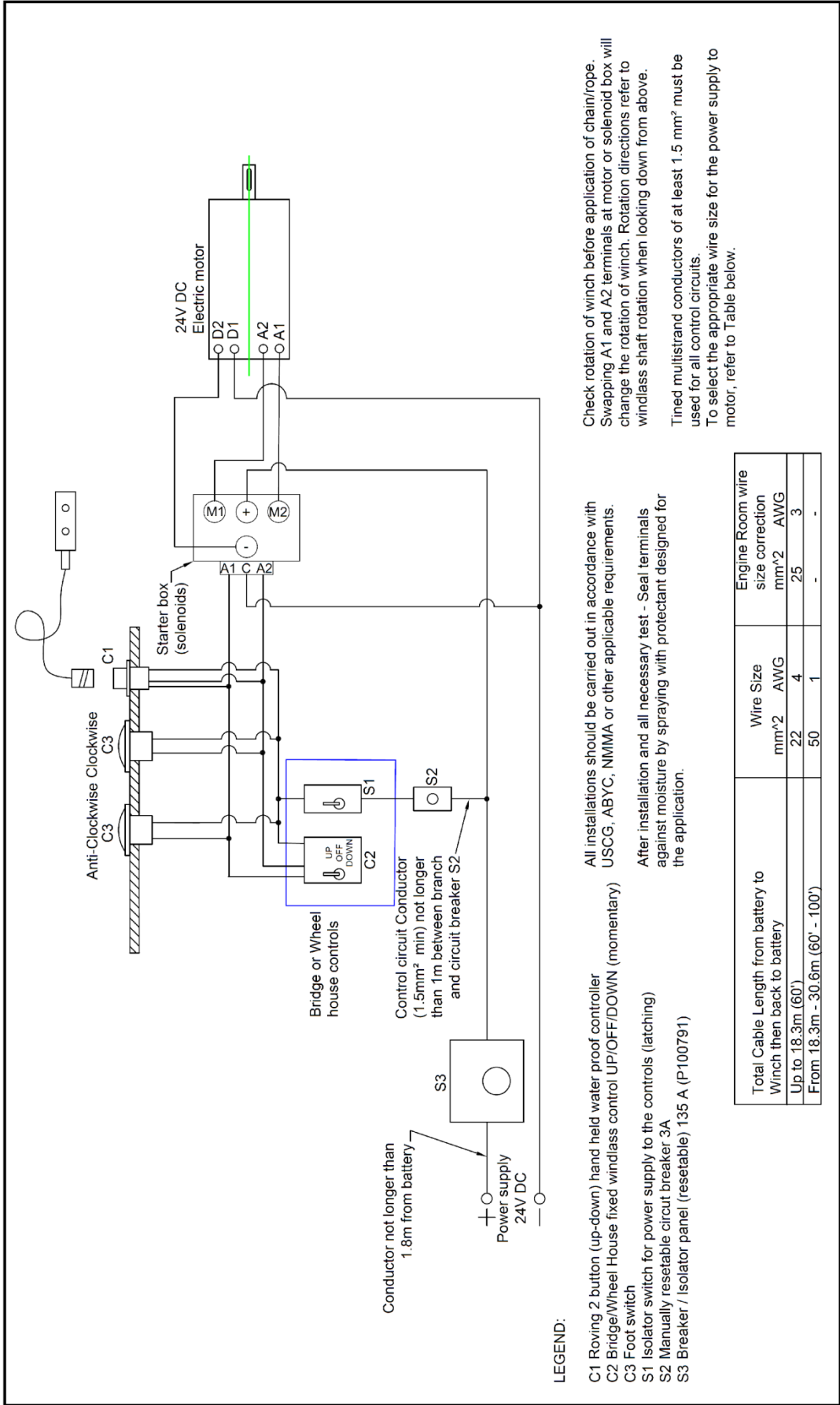

MAXWELL MARINE LTD
AUCKLAND NEW ZEALAND

WIRING SCHEMATIC FOR 4 TERMINAL
ELECTRIC DC POWERED WINDLASS

P101862

Check rotation of winch before application of chain/rope.
Swapping A1 and A2 terminals at motor or solenoid box will change the rotation of winch. Rotation directions refer to windlass shaft rotation when looking down from above.
Tined multistrand conductors of at least 1.5 mm² must be used for all control circuits.
To select the appropriate wire size for the power supply to motor, refer to Table below.

All installations should be carried out in accordance with USCG, ABYC, NMMA or other applicable requirements.
After installation and all necessary test - Seal terminals against moisture by spraying with protectant designed for the application.

Total Cable Length from battery to Winch then back to battery	Wire Size mm ² AWG	Engine Room wire size correction mm ² AWG
Up to 18.3m (60')	22 4	25 3
From 18.3m - 30.6m (60' - 100')	50 1	- -

Revision	Description	Date	Name
1.00	Initial issue	13/8/2014	GB

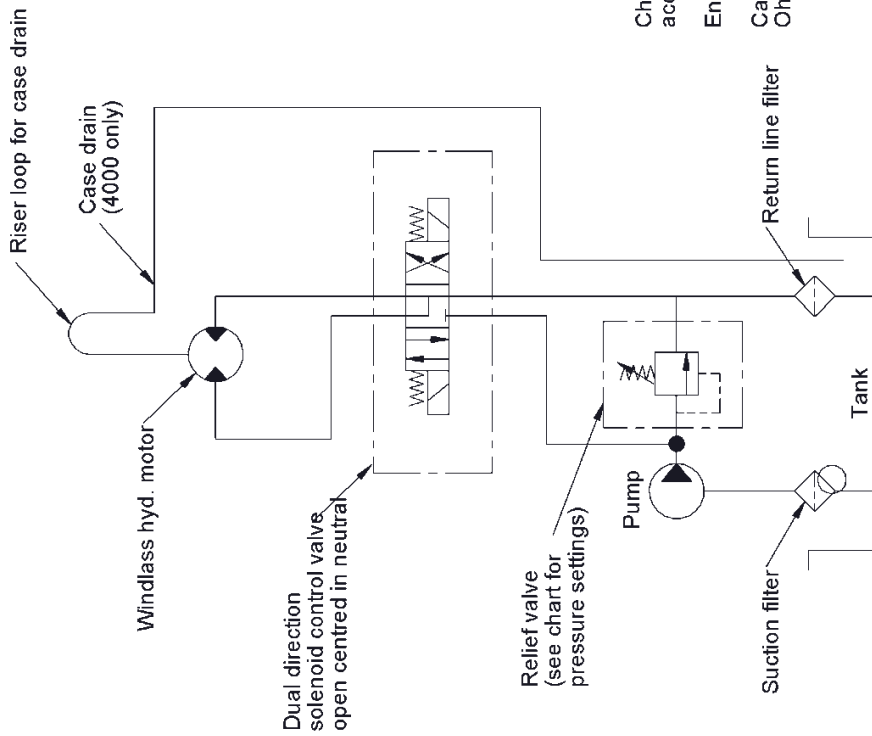

Series	Windlass		Recommended flow		Relief valve pressure setting	
	Motor	l/min	US gal/min	PSI	bar	
1000	P14366	20	5.3	1450	100	
1500	P14366	20	5.3	2000	138	
2200	P14369	36	9.5	1970	135	
2500	P14369	36	9.5	1970	135	
Liberty	P14368	32	8.5	2000	138	
RC12	P14368	40	11	2000	138	
3500	P14368	40	11	2000	138	
4000	SP2250 Galtech 2SM-A-19	50	13.2	1500	103	

Chart refers to MAXWELL "standard build". Lower flow or lower pressure can be accommodated - refer to manual or consult MAXWELL.

Ensure that selected hydraulic components are adequate for recommended flow rate.

Case drain can only connect to return line if return line pressure is below 25 PSI. Otherwise case drain must connect to tank

HYDRAULIC SCHEMATIC WINDLASSES 1000 - 4000

MAXWELL WINCHES LTD.
AUCKLAND NEW ZEALAND

P101820

Revision	Description	Date	Name
8.00	Directional control valve changed back	22/10/04	JE
9.00	4000 motor changed from SP2224 to SP2250	20/03/07	JE
10.00	Riser loop for case drain added	08/10/09	RP/JE
11.00	Motor for 2500 changed from P14368 to P14369	09/03/12	GB/DH

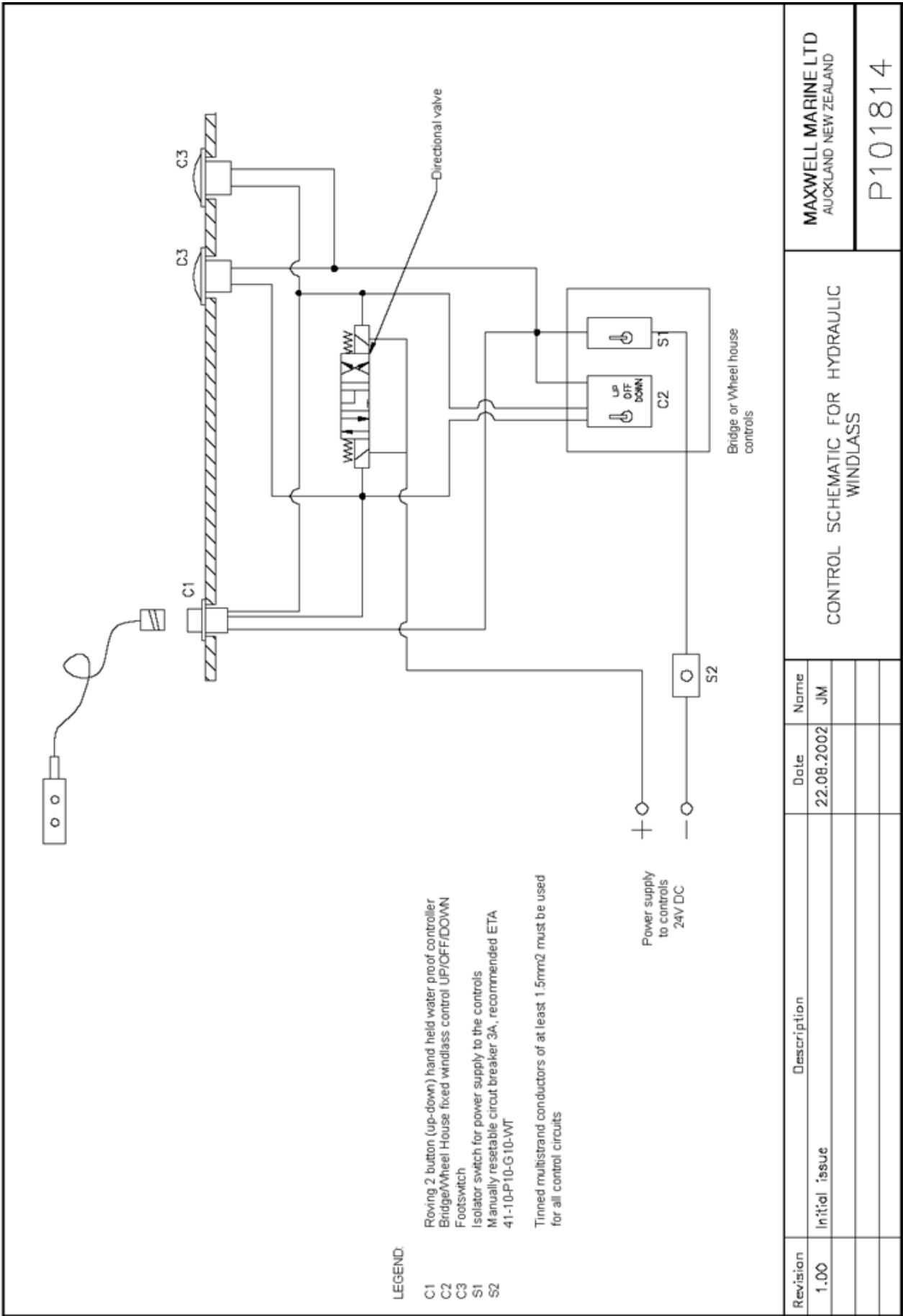

MAXWELL MARINE LTD
AUCKLAND NEW ZEALAND

P101814

CONTROL SCHEMATIC FOR HYDRAULIC WINDLASS

Revision	Description	Date	Name
1.00	Initial issue	22.08.2002	JM

(This page intentionally left blank)

LIMITED WARRANTY

Warranty: VETUS-Maxwell APAC Ltd (Maxwell) provides a three year limited warranty on all windlasses for pleasure boat usage, and a one year limited warranty for those systems used on commercial or charter vessels. Warranty, service and parts are available around the world. Contact your nearest Maxwell office for a complete list of service centres and distributors.

This warranty is subject to the following conditions and limitations:

1. This Warranty will be null and void if
 - a. there is any neglect or failure to properly maintain and service the products.
 - b. the products are serviced, repaired or maintained improperly or by unauthorised persons.
 - c. loss or damage is attributed to any act, matter or omission beyond the reasonable control of Maxwell or the purchaser.
2. Maxwell's liability shall be limited to repair or replacement (as determined by Maxwell) of the goods or parts defective in materials or workmanship.
3. Determination of the suitability of the product and the materials for the use contemplated by the buyer is the sole responsibility of the buyer, and Maxwell shall have no responsibility in connection with such suitability.
4. Maxwell shall not be liable for any loss, damages, harm or claim attributed to:
 - a. use of the products in applications for which the products are not intended.
 - b. corrosion, wear and tear or improper installation.
 - c. improper use of the product.
5. This Warranty applies to the original purchaser of the products only. The benefits of the Warranty are not transferable to subsequent purchasers.
6. Maxwell shall not be responsible for shipping charges or installation labour associated with any warranty claims.
7. There are no warranties of merchantability, fitness for purpose, or any other kind, express or implied, and none shall be implied by law. If any such warranties are nonetheless implied by law for the benefit of the customer they shall be limited to a period of three years from the original purchase by the user.
8. Maxwell shall not be liable for consequential damages to any vessel, equipment, or other property or persons due to use or installation of Maxwell equipment.
9. This Warranty sets out your specific legal rights allowed by Maxwell; these may be varied by the laws of different countries. In addition, the purchaser may also have other legal rights which vary from country to country.
10. To make a claim under this Warranty, contact your nearest Maxwell office or distributor. Proof of purchase and authorisation from Maxwell will be required prior to any repairs being attempted.

To be eligible for warranty protection, please either complete the form below at the time of purchase and return it to the appropriate retailer or supplier of the goods, or fill out the electronic warranty form on our website, www.maxwellmarine.com

Purchaser

Name:

Address:

Telephone: Facsimile

Supplier / Dealer

Name:

Address:

Telephone: Facsimile

Windlass Model

Serial Number

Date of Purchase

Boat Type

Windlasses Supplied

With boat

Fitted by boat yard/dealer

Purchased from dealer/chandler

Name L.O.A.

Built by

