

**3500 VW VWC VWCLP
OWNERS MANUAL**

VETUS-MAXWELL APAC Ltd

© Copyright Vetus-Maxwell APAC Ltd. All rights reserved.

Vetus-Maxwell APAC Ltd reserves the right to make engineering refinements on all products without notice. Always consult manual supplied with product as details may have been revised.

Illustrations and specifications are not binding as to detail.

Contents

1.0	INTRODUCTION	2
1.1	PRE-INSTALLATION NOTES	2
1.2	PRODUCT VARIATIONS	3
1.3	SPECIFICATIONS	4
2.0	INSTALLATION	6
2.1	SELECTION OF POSITION FOR THE WINDLASS	6
2.2	PREPARATION OF MOUNTING AREA	7
2.3	PREPARATION OF THE WINDLASS	8
2.4	INSTALLING THE WINDLASS	8
2.5	POWER CONNECTIONS TO DC MOTOR	10
2.6	POWER CONNECTIONS TO HYDRAULIC MOTOR	11
2.7	INSTALLATION OF CONTROLS	11
2.8	NOTE TO BOAT BUILDER	12
3.0	USING THE WINDLASS	13
3.1	PERSONAL SAFETY WARNINGS	13
3.2	LOWERING THE ANCHOR UNDER POWER	14
3.3	RETRIEVING THE ANCHOR UNDER POWER	14
3.4	LOWERING THE ANCHOR UNDER MANUAL CONTROL	14
3.5	RETRIEVING THE ANCHOR UNDER MANUAL CONTROL	15
3.6	OPERATING THE WARPING DRUM INDEPENDENTLY	15
4.0	MAINTENANCE	17
4.1	WINDLASS MAINTENANCE	17
4.2	BANDBRAKE MAINTENANCE	18
4.3	RECOMMENDED LUBRICANTS	18
4.4	SPARE PARTS	19
4.5	TOOLS FOR MAINTENANCE	19
5.0	TROUBLESHOOTING	20
	APPENDIX A - Dimensional drawings	22
	APPENDIX B - Spare Parts	26
	APPENDIX C - Installation schematics	31
	APPENDIX D - Warranty Form	36

1.0 INTRODUCTION

1.1 PRE-INSTALLATION NOTES

- Read this manual thoroughly before installation and using the windlass. Failure to adhere to the correct procedures, recommendations and guidelines described in this Owner's Manual may invalidate the warranty.
- Be mindful that the correct selection of windlass for each application, together with correct installation, normal care in use and maintenance, are essential for long life and reliable performance.
- Inspect your windlass carefully when unpacked. Any damage or lack of components should be reported immediately to your Maxwell distributor.
- The windlass is supplied with chainwheel, as specified on purchase order. Make sure it is the appropriate one for the chain being used on board. Correct fit of the chain to chainwheel is essential for reliable and safe operation of the windlass. This can be guaranteed only when calibrated chain to a recognised international standard is used and the chain is correctly identified to Maxwell, or if a chain sample is provided to Maxwell to develop a custom chainwheel.
- The windlass is designed for use in conjunction with chain stopper and tensioner of the appropriate size. Their use is an important safety feature.
- For side pocket anchors, a chain roller should be installed above the hawse pipe to ensure smooth and quiet travel of the chain from deck to hawse pipe. The roller requires a central groove to align chain and flat faces (for longer chains) to support and avoid bending the chain links.
- The connection of the power lines and control circuitry to the windlass must be done by skilled technicians, to ensure reliable and safe operation of the windlass.

1.2 PRODUCT VARIATIONS

There are several options of above-deck arrangements or “topworks”, combined with three types of drives.

The types of topworks are:

VWC - vertical windlass with chainpipe

VWCLP - vertical windlass with chainpipe, low profile

VW - vertical windlass

Each of the above topworks is available as clockwise or anticlockwise configuration (see description of Definition of rotation in Section 2.1).

Beside friction clutch, which can be used for controlling chain speed while free-falling anchor, the windlasses can also be equipped with an external band brake.

The types of drives are:

Electric DC drive (24V or 12V)

Hydraulic drive

For applications where deck is unusually thick, or is more convenient for drive to be positioned lower, Maxwell offers an extra deck clearance version which extends the drive by 100mm.

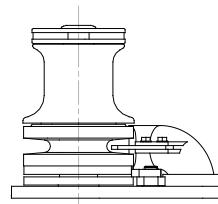

Picture 1.1
VWC Topworks

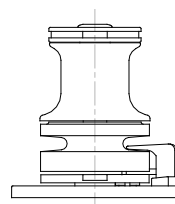

Picture 1.2
VW Topworks

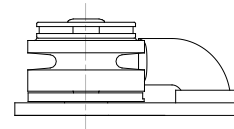

Picture 1.3
VWCLP Topworks

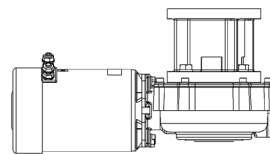

Picture 1.4
Electric DC drive

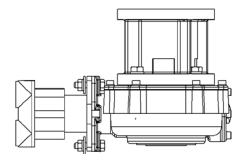

Picture 1.5
Hydraulic drive

1.3 SPECIFICATIONS

General	
Maximum stud link chain size	12.5mm (VW only)
Maximum short link chain size	14mm – VW 12.5mm – VWC VWCLP
Maximum pull capacity at chainwheel	1590kg (3500lb)

Electric DC Drive		
	12V	24V
Chain speed (at 200kg load)	15m/min (50ft/min)	15m/min (50ft/min)
Continuous pull capacity at chainwheel	533kg (1173lb)	533kg (1173lb)
Current at continuous pull rating	130-160A	66-82A
Motor power	1.2kW (1.6HP)	1.2kW (1.6HP)
Weight of windlass	65kg (143lb)	65kg (143lb)

Hydraulic Drive	
Chain speed (at recommended flow)	15 m/min (50 ft/min)
Recommended hydraulic oil flow	42 l/min (11 USgal/min)
Maximum hydraulic oil flow	48 l/min (13 USgal/min)
Continuous pull capacity	1590 kg (3500 lb)
Maximum hydraulic oil pressure	138 bar (2000psi)
Motor port size (pressure and return)	7/8" - 14 UNF
Minimum size of oil supply/return lines	16mm (5/8")
Weight of windlass	47kg (104lb)

Hydraulic oil characteristics

Viscosity:

ISO 32 - 68 (at 20°C)

Suitable oils:

Shell Rimula X 15W-40

Shell Myrina M 15W-40

Penzoil SAE 10W-40

Texaco 2109 SAE 15W

Texaco 1814 SAE 10W-40

BP HLPHM 32-68

BP Autrans T0410

Castrol Hyspin AWS 32-68

Chainwheels

The chainwheel numbers consist of two parts: main part number and suffix, for example 3182-001.

The main part number refers to the type of chainwheel and the suffix refers to size and type of chain.

Please refer to your closest Maxwell Marine agent or distributor (Appendix D), who will select the correct replacement chainwheel for your chain.

2.0 INSTALLATION

2.1 SELECTION OF POSITION FOR THE WINDLASS

Windlasses of this size will often be installed in pairs, giving an emergency backup in the event of mechanical or electrical failure. In this case one of the windlasses will normally be retrieving anchor running clockwise and the other anticlockwise.

Position of the windlass should be selected together with positions of hawse pipe and spurling pipe.

The deckplate should be installed pointing with its narrower end in the direction of the incoming chain. That allows the chain to have maximum engagement with the chainwheel.

Allow the chain a straight run from the bow roller to the chainwheel with no more than a 2° deviation from horizontal (Picture 2.1).

The bow roller should have a vertical groove to suit the profile of the chain. Its centre line should be tangential to the chainwheel (Picture 2.2). This will align the chain so that it enters the chainwheel without twisting.

When positioning the windlass, make sure that there is room to swing the clutch lever, so that it will clear the pulpit and life lines or bulwark.

The fitting of a chain stopper is essential to take the load off the windlass while the vessel is at anchor. It must be correctly aligned with the direction of chain and installed at appropriate height to avoid the chain rubbing over chain stopper body or pawl. Make sure the chain stopper clears the anchor stock.

A tensioner device to tension the anchor into its pocket is recommended. If the anchor is not snug in the pocket, it could cause damage to the pocket in a heavy seaway.

Ensure a minimum of 800mm (32") clearance between the end of spurling pipe and the chain piled up in the chain locker (Picture 2.3). This will assist kinks, which may develop in outgoing chain, to shake free.

The chain must gravity feed into the locker. If the chainpipe cannot be positioned directly over the locker, a heavy wall pipe can be used to direct the chain to the required area. It is important that the chain slips through the pipe easily; completely unaided. Sharp corners should be avoided. It may be necessary to provide the pipe with a bell mouth or to bell mouth the entrance to the chainpipe from the locker to assist the free flow of the chain from the locker.

The chain locker must be of such a size and shape that the chain will heap up and feed out naturally without fouling.

If it can be arranged, the chain locker bulkhead should pass between the chainpipe outlet in the deckplate and the gearbox. This will keep the gearbox, motor and power lines dry and away from flaying chain. Access for servicing from inside the cabin area can usually be arranged through a locker.

Note that the gearbox can be indexed through a number of different angles in relation to the windlass deckplate (Picture 2.4). Be sure to select the most convenient arrangement at installation and ensure

! **Definition of rotation**
Clockwise and anticlockwise rotation is defined as viewed from above the windlass. Most windlasses are used in one direction only.

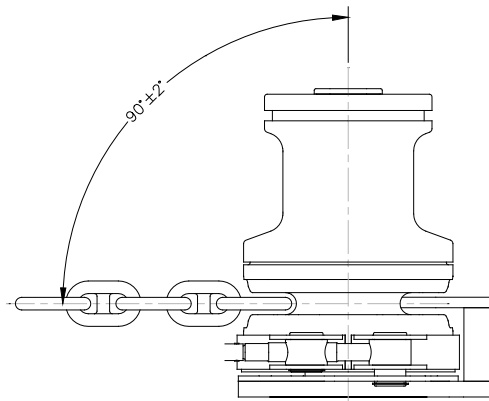

Picture 2.1

Direction of chain entering the chain wheel.

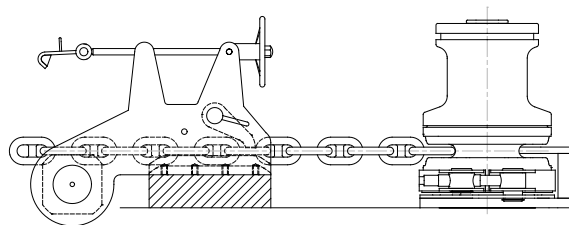

Picture 2.2

Correct height of Chain Stopper.

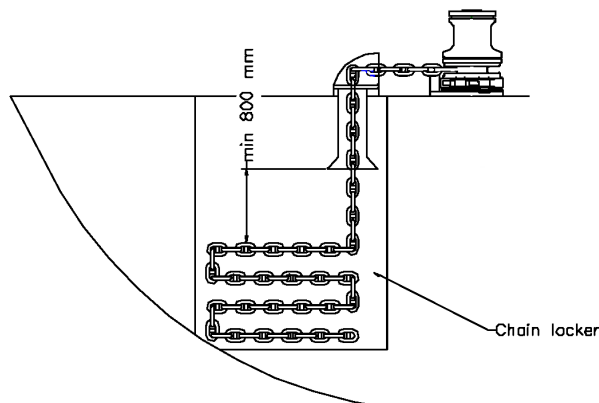

Picture 2.3

Recommended free space in chain locker.

incoming chain well clears the gearbox, motor and power supply lines.

To ensure safe position of the operator while tailing from the warping drum, footswitches should be positioned at least 500mm (20") away from the windlass.

The below deck portion of the footswitch should not be exposed to water or wet environment and the breather holes must be kept clear. The arrows on the footswitches should be arranged to indicate the direction of operation.

The motor starter (solenoid valves for hydraulic windlasses) should be located in a dry area in close proximity to the windlass. It must not be located in the wet environment of the chain locker.

The breaker/isolator panel (DC powered windlasses only) is selected to provide limited overload protection for the motor and full protection for the supply cables. It also provides the means for isolating the electrical system from the battery.

This should be mounted in a dry place within 1.8m (72") of cable length from battery.

This equipment or equivalent is mandatory to meet U.S.C.G. requirements.

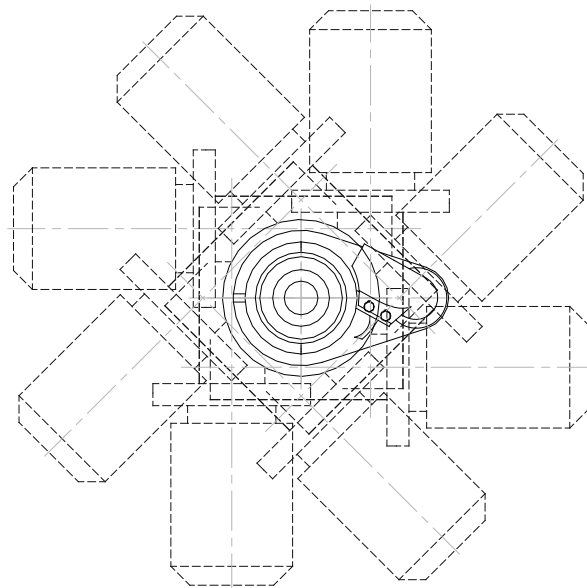

Picture 2.4

Positions of drive, relative to topworks.

2.2 PREPARATION OF MOUNTING AREA

It is of paramount importance that the vessel has sufficient deck reinforcing and total structural strength to sustain the loads that can be transmitted to the mounting area of the windlass and chain stopper. This should be equal to the loading of the equipment to beyond breaking strength of the chain.

The mounting area for the windlass must be perfectly flat and rigid. Structural grade fillers can be used to level this area if initial flatness is inadequate. Mounting area for the chain stopper should be prepared at the same time. The chain stopper has to be installed at an appropriate height to ensure that chain lays horizontally when it comes out of the chain stopper and into windlass. Maximum allowed angle deviation in vertical plane is $\pm 2^\circ$.

If hawse pipe is angled outboard from deck to anchor pocket, the chain stopper should also be angled by half of the angle of the hawse pipe (Picture 2.5). That will help to reduce twisting of the chain between the chain stopper and the windlass and ensure good fit of the chain into the chainwheel. The chain stopper can be installed vertically if the hawse pipe angle is less than 4° .

A deck cutout detail drawing is enclosed with these instructions to assist in marking out all the drilling and cutting required for installing the windlass. Before drilling and cutting, check the marked out area is dimensionally correct and make any necessary corrections.

The hole for mounting band brake guide (where applicable) should be marked and drilled after assembling the band brake on the windlass.

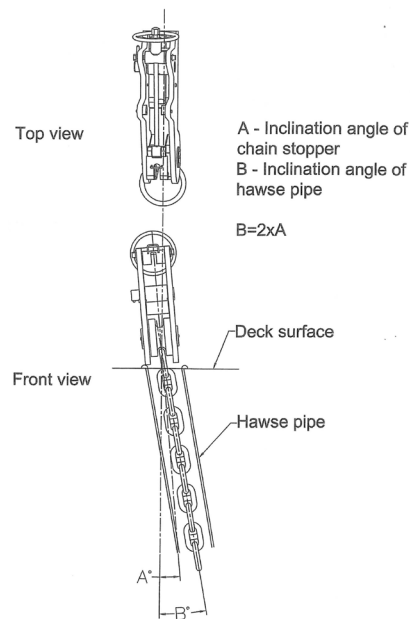

Picture 2.5

Installation angle of chainstopper

! Boats with steel/aluminium construction.

It is very important to insulate the deckplate from the boat with a non conductive gasket.

Mounting studs and fixings under the deck should be insulated. Anchor and chain should also be insulated, including rubber lining, chain locker and fixing for the end of the chain to the hull.

Without these precautions severe electrolysis can occur.

It is not necessary to separately earth the Windlass, as the electric motor is of the isolated earth type.

2.3 PREPARATION OF THE WINDLASS

Remove windlass from its packing case. Disassemble it in the following order (refer to drawing in Appendix B):

- Remove the cap (1) from the top of the windlass, taking care not to damage the chromed surface.
- Undo and remove the retaining screw (3) and retaining washer (4) under the cap, using a flat screw driver.
- Undo and remove clutch nut (5)
- For VW and VWC models only - remove drum (6),
- Remove upper clutch cone (7) and disc spring (8).
- Undo screws (29) that retain chain stripper (31) and remove it.
- Remove chainwheel (9), disc spring (8), lower clutch cone (7), keys (16) and retaining clips (10).
- With non-band brake versions remove washer (11), spring (12) and emergency crank collar (13).
- Undo screws (14) and remove the deckplate (19).
- Refer to Appendix B of this Manual and identify all parts. If any parts are damaged or missing, contact your Maxwell distributor. Some smaller parts might not be assembled on the windlass by the factory, but supplied in a plastic bag in the packing case.

Maxwell strongly recommends generous application of a high quality anti-corrosive paste or coating to the mating sections of main shaft, drive key, flanges, screw threads, dowels and other surfaces that are likely to seize after being in contact for a prolonged period of time.

Also ensure anti-corrosive coating is liberally applied to the inside wall of the spacer tube.

2.4 INSTALLING THE WINDLASS

Refer to the drawing in Appendix B for help with identifying components and installing them correctly. Extra care should be exercised when handling polished parts to avoid any damage to polished surfaces.

When assembling the parts, apply an anti-seize compound generously over all screw threads, keys and keyways, main shaft and inside the spacer tube.

Proceed with installation in the following order:

- After cutting holes for the windlass in the deck, apply an appropriate bedding/sealing compound and bolt the deckplate (19) to the deck using mounting studs (21), washers (22, 15) and nuts (23). Tighten them evenly to 35-40 Nm (25-30 ft lb). The chainpipe (30) and the pawl (26), if applicable, should already be assembled to the deckplate.
- Offer up, from below deck, the drive assembly sliding the mainshaft through the deckplate, taking care not to damage the deck bearing.

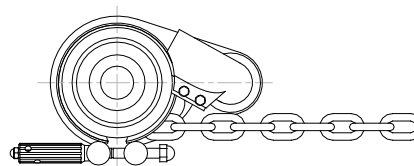

Picture 2.6
Clockwise topworks.

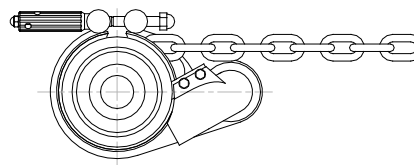

Picture 2.7
Anticlockwise topworks.

! When installing the Windlass, the shaft MUST be coated in Shell Nautilus NLG12 Marine Grease, Castrol Boating Grease, Vavoline Val Plex EP or equivalent grease.

- After aligning them correctly, bolt the deckplate and spacer tube together, from above deck, using the hex head screws (14) and spring Washers (15). Tighten them evenly to 35-40 Nm (25-30 ft lb).
- Re-check that the position of the drive assembly is satisfactory and convenient for connecting power supply lines to the motor. Also, make sure that the drive is not in the way of chain coming into the locker.
- If a chain counter is used, its sensor should be fitted into the Ø15mm hole in the deckplate, currently covered with a plastic plug (18). Make sure the deck is drilled below for the sensor cable. See brochure supplied with chain counter for detailed assembly instructions.
- Slide the emergency crank collar (13) over the mainshaft and then the spring (12) on top of it. For band brake models, the emergency crank collar and spring is not required and a seal would be used in place of the washer (picture 2.8).
- Insert the two retaining clips (11) into the upper groove in the mainshaft; apply some grease to help keep them in position.
- Apply anti-seize compound generously over the mainshaft and keyway. Insert key(s) (16) into the keyway on the mainshaft.
- Assemble the lower clutch cone (7) making sure it sits nicely on the retaining clips (Picture 2.8). Apply lithium based marine grease generously to the conical surface of the clutch cone, to assist with free falling the anchor.
- Put the disc spring (8) on top of the lower clutch cone (7) and install the chainwheel (9).
- Install band brake (if applicable) on the chainwheel, putting its fork over the pawl pin (28). The band brake can be assembled with its handle to either side of the windlass, choose more convenient option.
- Install upper clutch cone (7), after applying marine grease to its conical surface (see picture).
- Assemble drum (6) on top of the clutch cone (VW and VWC models only).
- Assemble clutch nut (5).
- Put retaining washer (4) on top of the mainshaft and secure it with the countersunk screw (3).
- Insert the cap (1) into the clutch nut.

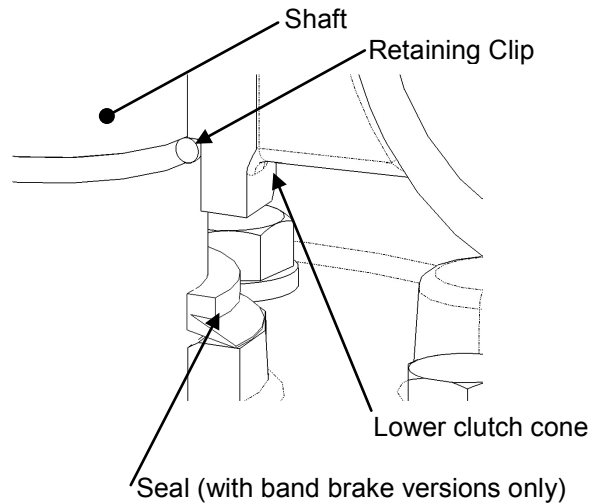

Picture 2.8
Clutch Cone / Retaining Clip / Seal Assembly

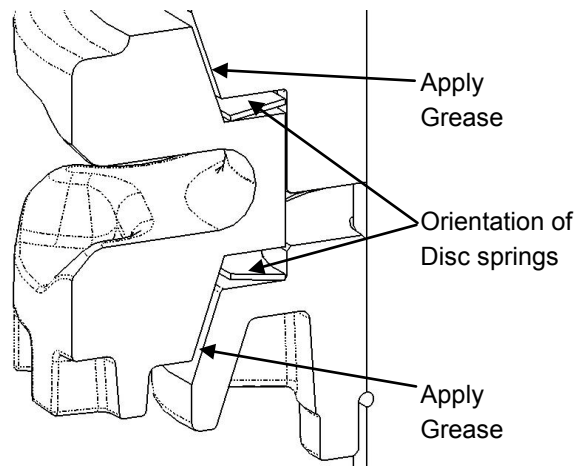

Picture 2.9
Greasing clutch cones and spring orientation.

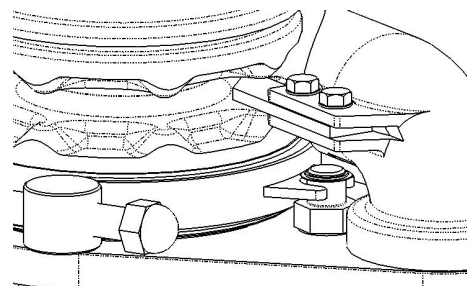

Picture 2.10
Band Brake Assembly.

! For effective operation of the band brake, the friction lining must remain free from contamination by any lubricant. Lithium complex base grease should, however, be applied to the lead screw thread.

2.5 POWER CONECTIONS TO DC MOTOR

The main power system is a two cable, ungrounded, fully insulated, negative return system. The motor is of the isolated earth type. This system is selected to minimise electrolytic corrosion problems.

The DC motor has three power terminals, marked "F1", "-" and "F2". Terminal "-" should be connected directly to "-" terminal on the battery, see wiring schematic in Appendix C. Terminal "F1" is for clockwise rotation of the motor and "F2" is for anticlockwise rotation. Depending on the desired direction of rotation, one of these terminals should be connected to solenoid.

See Table 2.1 to select the appropriate cable size for power supply. The recommendation assumes that the cable insulation has a minimum temperature rating of 90°C and sizes allow for a maximum 10% voltage drop over the total length.

Cable lengths given are from the battery terminal to the terminal on the motor, via the solenoid box, and then back to the battery.

Where a portion of cable runs through the engine room, a size increase should be made as indicated.

After connecting the cables, spray all terminals with anti-corrosive waterproof coating, "CRC 3013 Soft Seal" or equivalent.

! When tightening the cables to the motor, ensure the lower nut is secure against turning when tightening the upper nut. This will prevent damage occurring within the motor.

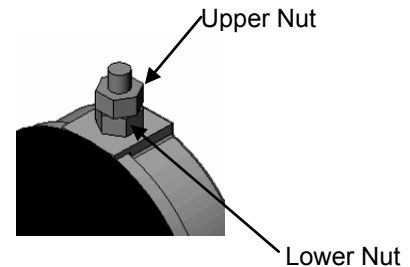

Picture 2.11
Motor Connections

12v Systems				
Total Cable Length from battery to winch then back to battery	Wire Size		Engine Room Wire Size Correction*	
	mm ²	AWG	mm ²	AWG
Up to 12.2m (40')	34	2	42	1
From 12.2m – 15.3m (40' – 50')	42	1	-	-
From 15.3m – 21.4m (50' – 70')	54	0	-	-
From 21.4m – 24.4m (70' – 80')	67	00	-	-
From 24.4m – 30.6m (80' – 100')	85	000	-	-

24v Systems				
Total Cable Length from battery to winch then back to battery	Wire Size		Engine Room Wire Size Correction*	
	mm ²	AWG	mm ²	AWG
Up to 18.3m (60')	16	6	22	4
From 18.3m – 30.6m (60' – 100')	22	4	-	-

Table 2.1
Recommended wire sizes

2.6 POWER CONECTIONS TO HYDRAULIC MOTOR

A basic hydraulic schematic is shown in Appendix C. Port sizes on the hydraulic motor and minimum hose sizes are specified in Section 1.3.

The motor has pressure and return ports (bigger) and a case drain ports. The pressure and return ports should be connected to a solenoid controlled valve (not supplied by Maxwell).

After connecting the power lines, spray all ports and fittings with anti-corrosive waterproof coating, "CRC 3013 Soft Seal" or equivalent.

2.7 INSTALLATION OF CONTROLS

The windlass can be operated using:

- Deck mounted footswitches
- Hand held pendant controller (single or dual speed)
- Helm switch (single or dual speed)
- Chain counter

These control accessories are available from Maxwell customised to suit your windlass.

It is the choice of the designer/builder to use one, two or all three of these controls. They are wired in parallel to the directional valve (for hydraulic windlasses) or to the starter unit (for electric windlasses). The controls can work on 12 or 24V power supply.

If footswitches are used, then an isolator switch for them must be installed in the wheelhouse, to prevent operating the windlass by someone accidentally stepping on the footswitch.

Hand held pendant controller is often the most convenient way of operating the windlass. Maxwell offers several variations of pendants, including single speed, dual speed, single pendant for running a pair of windlasses, pendants with auxiliary buttons which can be used for starting chain wash system, hydraulic pump etc. They are supplied with a plug on the other end of cable and a matching waterproof socket, which should be installed on a convenient location on the deck.

All units are supplied with detailed wiring instructions to assist installation.

Refer to wiring schematics in Appendix C for control circuits. All control wiring should be done using no smaller than 1.5mm² wire (AWG 16).

Where applicable, a manually re-settable, ignition proof 3A breaker or fuse should be installed on the power supply line for controls, within 1m (40") from the main breaker/isolator. These requirements are mandatory to meet USCG, ABYC and NMMA rules.

After connecting the power lines, spray all ports and fittings with anti-corrosive waterproof coating "CRC 3013 Soft Seal" or equivalent.



Picture 2.12
Hand Held Pendant controller.

2.8 NOTE TO BOAT BUILDER

Experience has shown that, on long ocean deliveries, sulphur from the ship's exhaust can settle on polished surfaces, which can affect the quality of the finish.

Please ensure that, upon completion of installation, the windlass is treated with suitable corrosion protective coating ("CRC 3097 Long Life") and wrapped in plastic film. This ensures that your customer receives the windlass from you in the same top quality condition as you received it from Maxwell.

3.0 USING THE WINDLASS

3.1 PERSONAL SAFETY WARNINGS

- As with all load carrying equipment, the consequences of heavy overload, neglect or misuse may be unexpected failure and exposure of crew and/or vessel to risk. Operate the windlass with extreme care at all times.
- Before testing the windlass for the first time, check that all the wiring has been done correctly.
- When using the windlass at all times practice good seamanship and adhere to the following rules in order to avoid any likelihood of injury or accident.
- At all times keep hands, feet, loose clothing, cordage and your hair WELL CLEAR.
- Never operate the windlass from a remote station without maintaining a clear view of it and having made sure that everyone is well clear of the windlass, anchor and chain.
- Never use the windlass under power with the clutch handle inserted into clutch nut or emergency crank collar.
- When engaging the pawl while chain is running, keep fingers away from the chain. Use clutch nut lever, underneath and guarded by the chainpipe.
- Always motor up to the anchor position before retrieving it from the bottom. Do not use the windlass to pull the boat to the anchor.
- If the anchor is fouled, do not use the windlass to break it out. With the chain stopper taking the load, use the boat's engine to break the anchor loose.
- When lowering the anchor under manual control, use the band brake or friction clutch (if fitted) to control the speed of the chain. Never lower the anchor without maintaining safe chain speed.
- When the windlass is not in use, make sure the power supply is isolated, making an accidental operation thereby impossible.
- Do not use the windlass as an anchoring point for the chain. Engage the chain stopper when the windlass is not in operation.
- Never proceed at speed without first ensuring that the chain stopper is engaged. Also engage the tensioner to keep the anchor snug in the pocket.
- When using the windlass, do not switch immediately from one direction of rotation to the other, without waiting for windlass to stop. Abuse is not covered by warranty.

3.2 LOWERING THE ANCHOR UNDER POWER

- Ensure the clutch is fully engaged by inserting the clutch nut lever in one of the slots on the clutch nut, and turning clockwise firmly. The windlass is equipped with a friction clutch, so it can be engaged in any position (there is no need to match the position of the opposite sides of the clutch before engaging it).
- Remove clutch handle.
- Release band brake or pawl (whichever is fitted).
- Disengage chain stopper and chain tensioner (if fitted). To disengage the chain stopper pawl the windlass may require momentary jogging in the up direction.
- The windlass may now be lowered under power by operating either the hand held pendant control, helm switch or footswitch.
- When finished, turn off the isolator switch for the controls.

!

As a safety feature all buttons on the controls (pendant, toggle switch or footswitch) non-latching and the windlass will continue to operate up or down only while the switch is physically held in the engaged position.

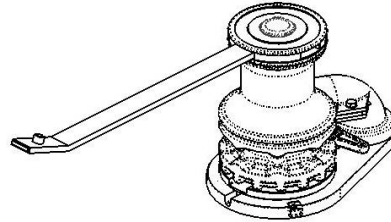

Picture 3.1

Engaging the clutch.

3.3 RETRIEVING THE ANCHOR UNDER POWER

- Ensure the clutch is engaged, as described above, and band brake or pawl is released.
- Remove clutch handle from the clutch nut.
- Release tensioner. If a pawl type chain stopper is used, it can be left ratcheting on the chain, so it will engage itself automatically when the windlass stops.
- The windlass may now be operated to raise the anchor.
- After retrieving the anchor make sure the chain stopper and tensioner are engaged.
- Turn off the isolator switch for the controls.

!

It is regarded as sound practice to motor over the anchor position and so reduce chain tension. This will also help the anchor to break out, reduce the power consumption and reduce load on the windlass and deck gear.

!

Care should be exercised when docking the anchor to avoid damage to the anchor pocket. Jog in the last meter (3-4') of the chain carefully seating the anchor home.

3.4 LOWERING THE ANCHOR UNDER MANUAL CONTROL

This method will normally be employed to lower the anchor quickly, to lower it in "quiet ship" and in emergencies (power loss or control failure).

Proceed as follows:

- Tighten the clutch and band brake (if fitted).
- Release the chain stopper and chain tensioner. If the anchor has to be lowered in case of power loss and pawl on the chain stopper is engaged and under tension (by chain), to release it, pull the chain in slightly, using tensioner. Once the pawl is disengaged, release the tensioner and disengage it. If there is too much slack in the chain, it might be necessary to remove the domed nut from the end of lead screw and release the screw completely. If doing that, make sure the band brake and clutch is still engaged, for safety reasons (see Picture 3.2).
- Fully disengage the clutch by turning the clutch nut anticlockwise until it comes to a stop.
- Slowly release the band brake in a controlled

!

It is considered potentially dangerous to allow the chain to free fall in an unrestricted manner - always control the chain speed.

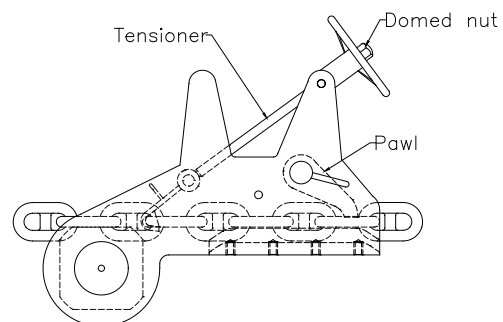

Picture 3.2

Chain roller-stopper-tensioner.

manner. The chain should now release, the weight of self-launching anchor being sufficient to draw out the chain. Regulate the chain speed by gradually engaging/disengaging the band brake.

- When the required amount of chain is out, tighten the band brake and engage the chain stopper.
- If the band brake is not fitted, the speed of chain can be controlled by the clutch. In that case, after disengaging the chain stopper, slowly release the clutch by inserting the lever into the clutch nut and turning it anticlockwise. Regulate the chain speed by gradually engaging/disengaging the clutch.
- To apply more torque when engaging the band brake, the brake is equipped with a bar, which can be inserted into the brake handle as a lever (Picture 3.3). The bar is normally stored inside the handle.

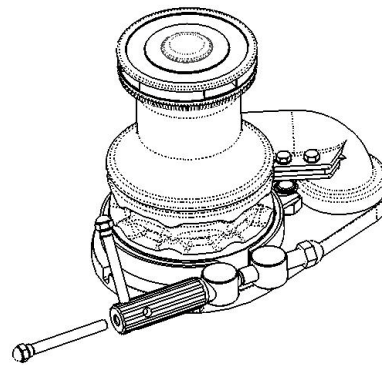

Picture 3.3
Using band brake lever.

3.5 RETRIEVING THE ANCHOR UNDER MANUAL CONTROL

The windlass (models without band brake only) is equipped with a cranking mechanism to retrieve the anchor in case of emergency. It involves operating the windlass manually under heavy load and extra care must be exercised when using it to avoid injury. To use proceed as follows:

- Check that the chain stopper is engaged. If a chain stopper is not fitted, ensure that the pawl (26) is engaged with the chainwheel (9).
- Insert the clutch nut lever in the clutch nut and release clutch by turning the clutch nut in anticlockwise direction.
- Insert the clutch nut lever (the end with spigot) into the emergency crank collar (13) and engage the spigot with one of the dogs in the chainwheel in the furthest forward position (Picture 3.4).
- Pull the lever back as far as possible, bringing the chain in. Engage the pawl (26) and ease off the lever.
- Push lever to furthest forward position and re-engage with the chainwheel.
- Repeat the cycle until the anchor is retrieved. It is a very slow process and should be used only in emergencies.

! The chain slack between the tensioner and the windlass should be kept to less than the end travel of the tensioner. This allows for safe disengagement of the tensioner and transfer of load to the chainwheel.

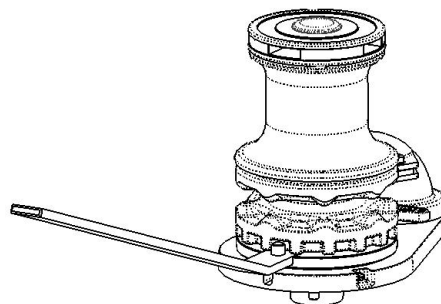

Picture 3.4
Emergency crank position.

3.6 OPERATING THE WARPING DRUM INDEPENDENTLY

This is applicable to VW and VWC models only. The drum can be operated independently of the chainwheel and can be used to manage docking lines or a second anchor. To use in this way, proceed as follows:

- Engage the chain stopper, the pawl or the band brake (whichever is fitted).
- Fully disengage the clutch as described in Section 3.4.

The drum may now be operated independently of the

! While handling docking lines with the capstan, ensure everyone stays well clear of the lines and the capstan.

chainwheel. Maxwell recommends all warping operations be controlled by the footswitch. This makes it a one-person operation and offers better control of the capstan in case of emergency.

Take several turns of the warping line around the drum and pull on the rope tail with sufficient manual force to provide good grip of the line to the drum, whilst operating the footswitch. Make sure the drum is operated in the same direction as the line is wrapped around it.

Do not engage more turns on the drum than are necessary to accomplish the task. Whilst docking, wind and tide can impose sudden and excessive line tension. It is recommended to allow slipping to occur at the drum. This will protect the capstan, docking lines and vessel from damage.

! Take care not to allow “riding turns”. This is caused by the loaded line climbing on top of lower loaded coils on the drum. A riding turn can only be removed by paying the line out to the point where the riding turn is created.

4.0 MAINTENANCE

4.1 WINDLASS MAINTENANCE

Every Trip:

- The above deck parts should be washed down with fresh water.

Every 6 months:

- Disassemble the above deck components of the windlass (up to the deckplate) as described in Section 2.3.
- Clean all components and check for damage.
- Grease the components using lithium complex base, water proof grease.
- Clean chromed surfaces with a cloth, damp with kerosene. After cleaning spray them with "CRC 3037 Long Life" or alternatively, with "CRC 6-66" or "WD-40". Regular use of "CRC3097 Long Life" will assist in maintaining the bright chrome finish.
- Apply anti-seize compound on screw threads and keyways.
- Re-assemble in the reversed order.
- Split gearbox from the spacer tube. Clean and re-grease mating faces.
- Inspect the components below deck for corrosion, chipped paint etc, clean them and touch up the paint if necessary. Spray them for protection with "CRC 3013 Soft Seal".
- Spray fresh water into the drainage slot of gear box to breakdown and flush away any build up of salt/debris, which may have accumulated.
- Check the electric power connections and spray them with "CRC 3013 Soft Seal" for protection.
- Check the oil level in gearbox and top up if necessary. (See Section 4.3).

Every 12 months:

- Service Motor. The motors can be detached safely, without draining oil from the gearbox. If removing the motor, spray its shaft with an anti-corrosion spray before reassembling. The drive pin is press fit into the motor shaft and can be replaced if necessary.

Every 3 years:

- Remove gearbox and replace oil and seals.
- The quantity is indicated in Section 4.3.

! Failure to carry out the maintenance and service, as described herein, will invalidate warranty.

! Before doing any maintenance work on electric motor, starter units and wiring, make sure the power supply is switched off.

! Use synthetic oils only. Never mix two oils, even if they are from the same manufacturer.

4.2 BAND BRAKE MAINTENANCE

The frequency of brake lining renewal will depend entirely on its usage. Should visual inspection reveal that the lining thickness has worn to below 2mm or if the ends of brake band can touch each other when tight, renewal of brake lining is necessary.

Grease the band brake lead screw at least every three months.

Avoid grease contamination of brake friction linings.

4.3 RECOMMENDED LUBRICANTS

Greases

- Lithium complex base NLG1 consistency No. 2

- CASTROL LMX
- DUCKHAMS Keenol
- FINA CERAN WR 2
- SHELL Retinex LX
- MOBIL Mobilgrease HP

Gearbox Oils

- ISO 3448 VG 320

- CASTROL Alpha MAX 320
- SHELL Tivela Oil
- MOBIL Mobilgear 632
- BP MACH GR XP 320

Quantity-

DC and Hydraulic drives : 0.35 litres

Anti-Corrosive Coatings

- CRC 3013 Soft Seal
- Boeshield T9
- Lanocote

Anti-Seize Coating

- International Paints Res-Q-Steel

Never mix greases, use only one type. If in doubt, remove the previous lubricant and clean the parts thoroughly before applying the new one.

4.4 SPARE PARTS

Maxwell recommends a modest quantity of spare parts to be ordered as familiarity with the windlass is developed during installation. As small parts can be lost during maintenance, keeping spares (and spare tools) is recommended.

We recommend the following list of spare parts per windlass to be carried on board:

Part No.	Description	Qty
2311	Retaining clip	2
3227	Plastic cap	1
5953	Disc Spring	2
3207	VW, VWC Topworks key	2
3207	VWCLP Topworks key	1
SP0846	External Circlips	1
SP0740*	Seal	1
7068**	Washer	1
2310**	Spring	1

* This item is only required with band brake versions.

**These items are not required with band brake versions.

If any other spare part is required, please refer to Appendix B for the correct part number and contact one of our distributors worldwide (Appendix D). When ordering spare parts, please quote:

- Windlass model
- Serial number of the windlass
- Part number (see Appendix B)
- Part description
- Quantity required

4.5 TOOLS FOR MAINTENANCE

We recommend the following tools be kept on board for disassembling and assembling the windlass:

- Set of metric hexagon keys (Allan keys), sizes 8 and 10mm
- Ring / open end spanner 17mm, 19mm 8mm and 9/16"
- Flat screwdriver 10mm blade width
- Circlip pliers

5.0 TROUBLESHOOTING

Problem	Possible Cause	Solution
Windlass does not rotate.	No electric power to controls.	<p>Make sure the isolator switch for the windlass controls is ON.</p> <p>Check the fuse on power supply to controls.</p> <p>Make sure the wiring is correct and check it for damage.</p> <p>If there is more than one type of control (pendant unit, footswitch, helm switch), check them all in an effort to isolate the problem</p> <p>Check the power supply to controls from the source, step by step, and identify the point where it stops.</p>
	Incorrect or incomplete wiring.	Check wiring against diagrams supplied.
	No power supply to the windlass.	<p>Check power supply lines.</p> <p>Check main isolator switch.</p> <p>Check hydraulic pump.</p>
Windlass is not able to pull the specified load.	Motor voltage does not match the power supply on board.	Check name plate on the motor. If confirmed, contact Maxwell.
	Hydraulic relief valve not set correctly.	Check valve setting.
DC motor draws high current but struggles to pull the load.	The mounting bolts of the motor are touching the motor winding.	Make sure the bolts have spring washers and/or adjust bolt lengths.
Electric motor stops after prolonged heavy use.	The motor has been overloaded and has reached its maximum operating temperature.	Electric DC motors: Leave it to cool down and reset the circuit breaker.
Windlass runs but the chainwheel stays stationary.	The clutch is not fully engaged.	Tighten the clutch up, as described in Section 3.2. If the problem persists, contact Maxwell.
	Band brake is engaged.	Release band brake.
	Topworks key(s) (16) not installed.	Install the key.
The anchor does not free fall.	The clutch cones are not greased.	Disassemble the cones (7), clean and grease them as described in Section 2.4.
	The clutch is not fully disengaged.	Disengage the clutch fully.
	The band brake is not disengaged.	Disengage the band brake fully.
	Disc springs (8) not fitted.	Fit disc springs as described in 2.4.
	Pawl (26) engaged.	Disengage pawl.

Chain jumps / slips on the chainwheel.	The chainwheel not selected correctly.	Contact Maxwell with correct identification of the chain used on board.
	Chain twisted between windlass and bow roller.	Untwist the chain.
	Vertical angle of incoming chain bigger than 2 degrees (see Picture 2.1).	Check the installation. If the problem persists, some height adjustments might have to be made.

APPENDIX A – Dimensional Drawings

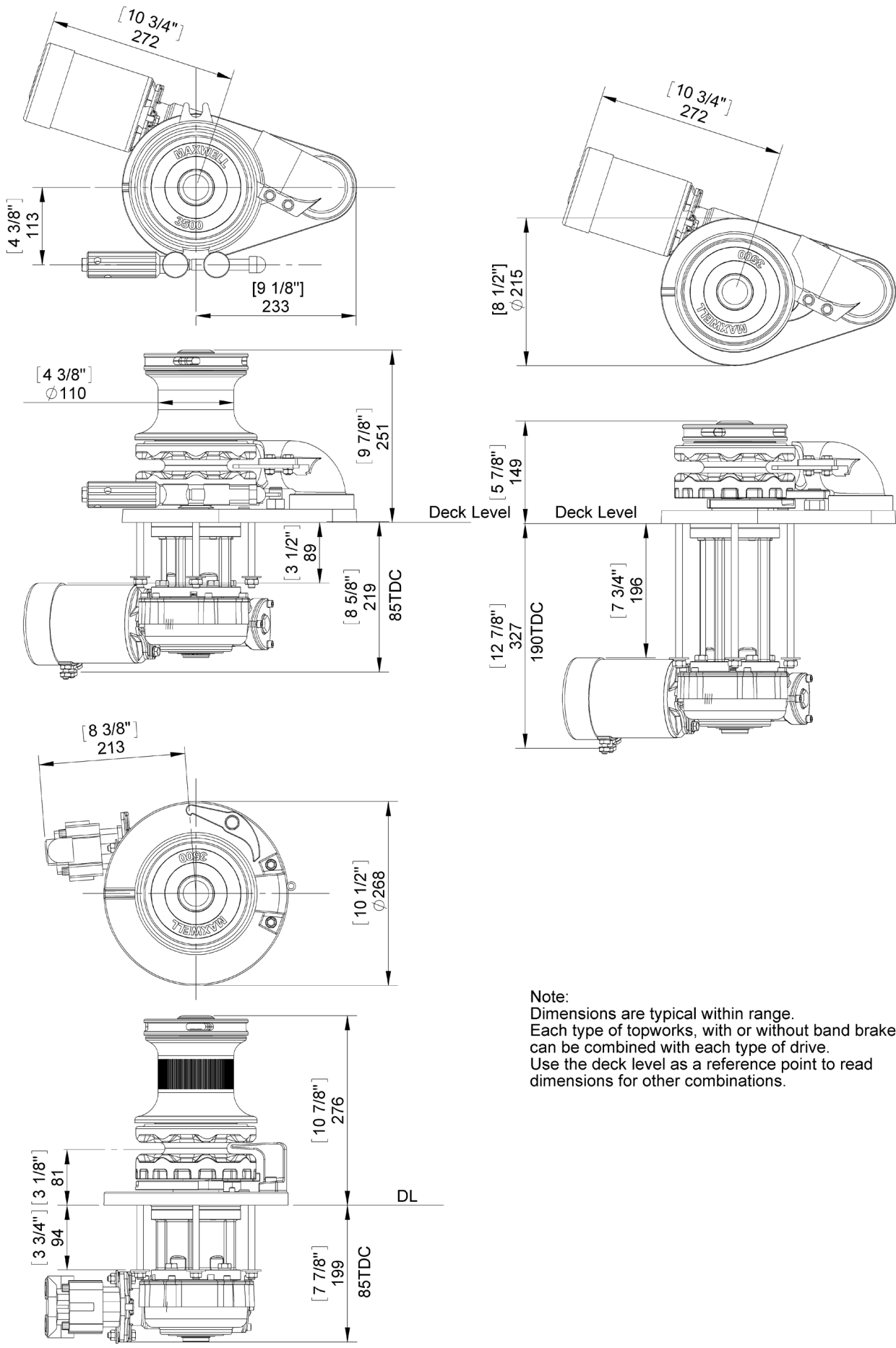

Note:
 Dimensions are typical within range.
 Each type of topworks, with or without band brake,
 can be combined with each type of drive.
 Use the deck level as a reference point to read
 dimensions for other combinations.

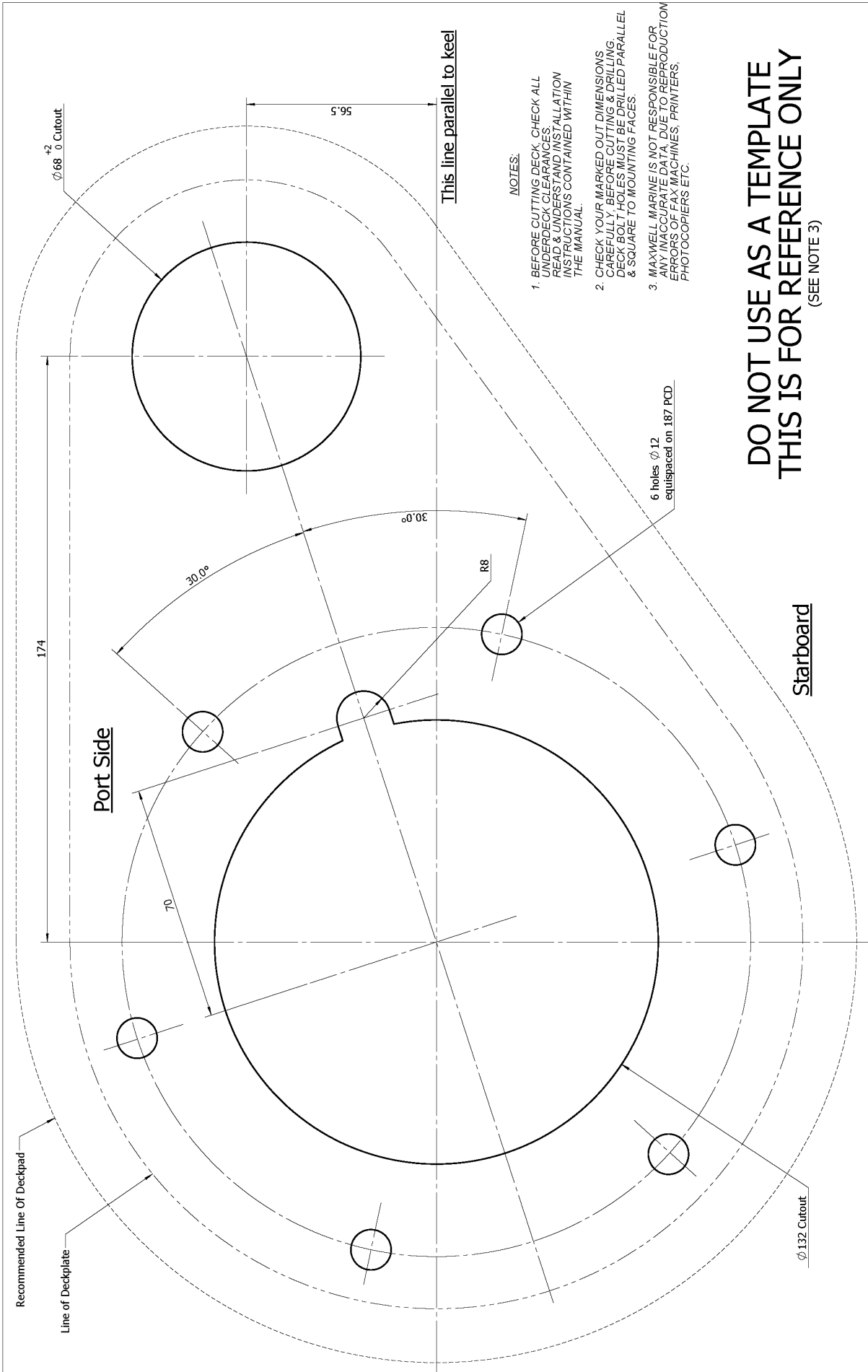

NOTES:

1. BEFORE CUTTING DECK, CHECK ALL UNDERDECK CLEARANCES READ & UNDERSTAND INSTALLATION INSTRUCTIONS CONTAINED WITHIN THE MANUAL.
2. CHECK YOUR MARKED OUT DIMENSIONS CAREFULLY BEFORE CUTTING. DRILLING DECK BOLT HOLES MUST BE DRILLED PARALLEL & SQUARE TO MOUNTING FACES.
3. MAXWELL MARINE IS NOT RESPONSIBLE FOR ANY INACCURATE DATA, DUE TO REPRODUCTION ERRORS OF FAX MACHINES, PRINTERS, PHOTOCOPIERS ETC.

**DO NOT USE AS A TEMPLATE
THIS IS FOR REFERENCE ONLY**
(SEE NOTE 3)

Revision	Made on/Drawn	Change	Description	Drawing No.	Revision No.
6.00	Issued in CAD	RP	Deck Cutout Details - 3000 3500 4000 VWCLP-VWC	3338	7.00
7.00	Template note added. Notes revised	RP			
Tolerances: <i>If none specified</i> 0 DECIMAL (X) ±0.5 1 DECIMAL (X.X) ±0.2 2 DECIMAL (X.XX) ±0.1			Material: N/A	Sheet Size: A3	Scale: 1:1
					Sheet: 1 of 1

This drawing is protected by copyright and the design and/or details contained herein are the property of MAXWELL MARINE LTD.
This drawing must be returned upon demand and must not be copied, loaned, reproduced, or otherwise used without the consent in writing from Maxwell Marine Ltd. This drawing must not be used for any other purpose other than that for which it was originally supplied.

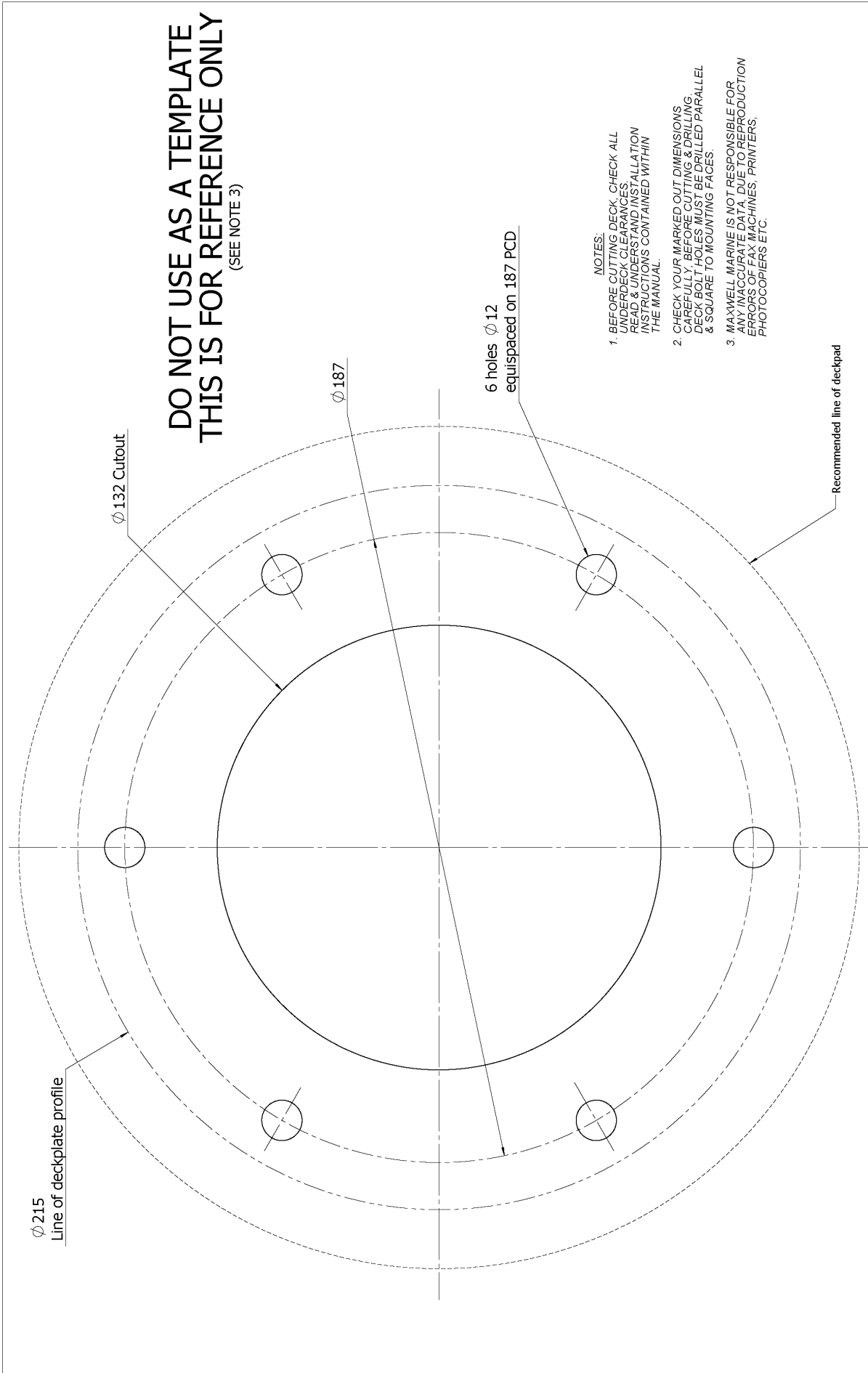

**DO NOT USE AS A TEMPLATE
THIS IS FOR REFERENCE ONLY**
(SEE NOTE 3)

NOTES:

1. BEFORE CUTTING DECK, CHECK ALL UNDERDECK CLEARANCES. READ & UNDERSTAND INSTALLATION INSTRUCTIONS CONTAINED WITHIN THE MANUAL.
2. CHECK YOUR MARKED OUT DIMENSIONS CAREFULLY, BEFORE CUTTING & DRILLING. DECK BOLT HOLES MUST BE DRILLED PARALLEL & SQUARE TO MOUNTING FACES.
3. MAXWELL MARINE IS NOT RESPONSIBLE FOR ANY INCURRING DAMAGE TO PRODUCTION ERRORS OF FAX MACHINES, PRINTERS, PHOTOCOPIERS ETC.

Revision	Change	Material	Description	Drawing No.	Revision No.
2.00	Issued in CAD			3341	3.00
3.00	Template note added. Notes revised		Deck Cutout Details - 3000 3500 4000 VC		Sheet
		N/A	Tolerances: if none specified 0 DECIMAL (X) ±0.5 1 DECIMAL (X.X) ±0.2 2 DECIMAL (X.XX) ±0.1		1 of 1
					Scale
					1:1
					Sheet Size
					A3

This drawing is protected by copyright and the design and or details contained herein are the confidential property of Maxwell Marine. This drawing must be returned upon demand and must not be copied, loaned or have its contents communicated to any other persons, including subcontractors, without the consent in writing from Maxwell Marine. We accept no liability for any errors or omissions for any purpose other than that for which it was originally supplied.

Revision	Change	Material	Description	Drawing No.	Revision No.
2.00	Issued in CAD			3341	3.00
3.00	Template note added. Notes revised		Deck Cutout Details - 3000 3500 4000 VC		Sheet
		N/A	Tolerances: if none specified 0 DECIMAL (X) ±0.5 1 DECIMAL (X.X) ±0.2 2 DECIMAL (X.XX) ±0.1		1 of 1
					Scale
					1:1
					Sheet Size
					A3

MAXWELL

Rev.	Issued in cad	Change	Made on Des/Drawn
2.00			8/3/05 RP
3.00	Template note added.	Notes revised	29/3/06 RP

This drawing is protected by copyright and the design and or details contained therein are the confidential property of MAXWELL MARINE LTD.
 This drawing must be returned upon demand and must not be copied, loaned or have its contents disclosed to any third party, including subcontractors, without the consent in writing from Maxwell Marine Ltd. This drawing must not be used for any other purpose other than that for which it was originally supplied.

Line of deckbearing profile

6 holes $\phi 10$ equispaced at $\phi 187.3$ mm PCD

$\phi 132$ Cutout

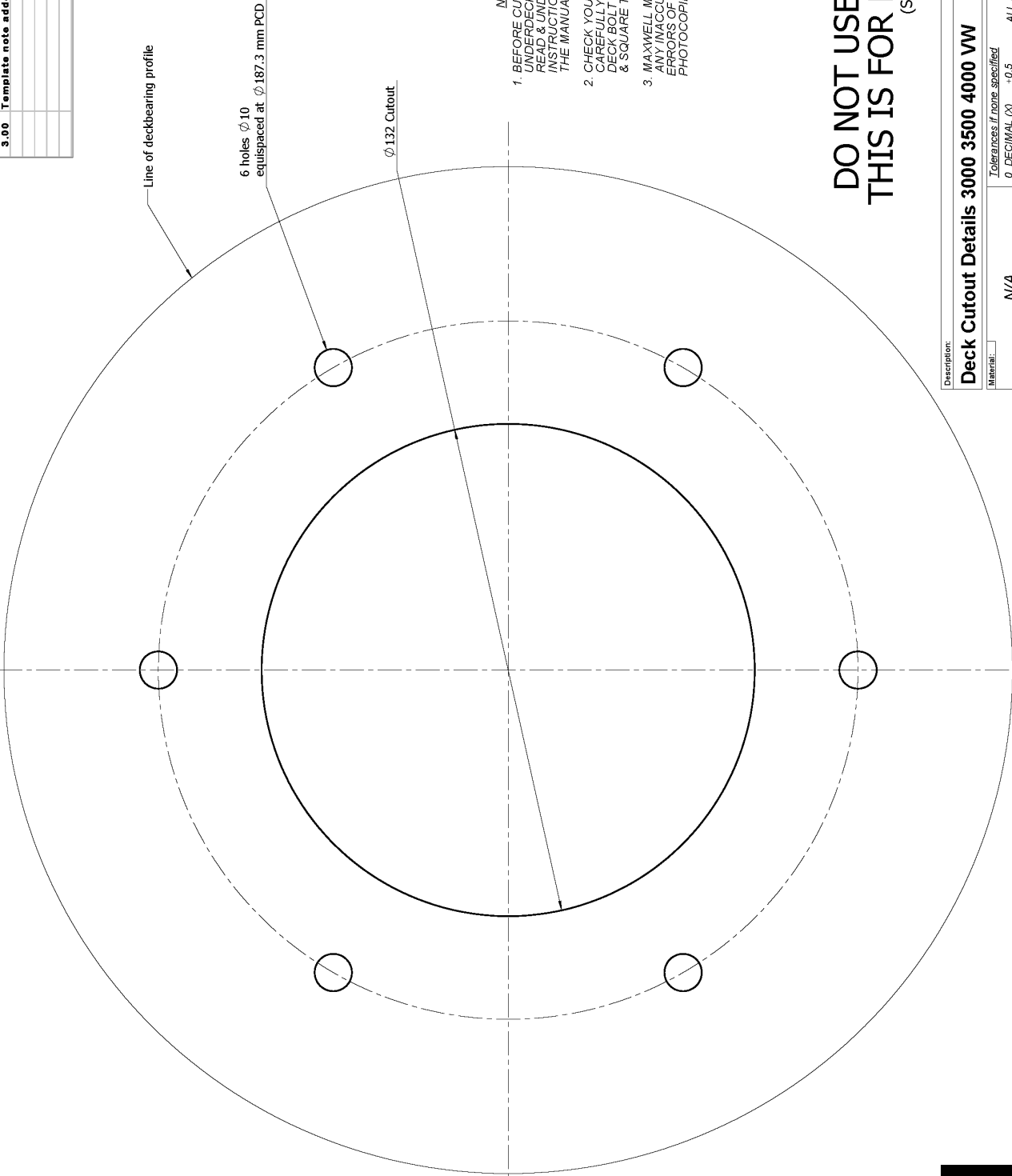

NOTES:

1. BEFORE CUTTING DECK, CHECK ALL UNDERDECK CLEARANCES. READ & UNDERSTAND INSTALLATION INSTRUCTIONS CONTAINED WITHIN THE MANUAL.
2. CHECK YOUR MARKED OUT DIMENSIONS CAREFULLY, BEFORE CUTTING & DRILLING. DECK BOLT HOLES MUST BE DRILLED PARALLEL & SQUARE TO MOUNTING FACES.
3. MAXWELL MARINE IS NOT RESPONSIBLE FOR ANY DAMAGE TO DATA, DUPLICATION ERRORS OF FAX MACHINES, PRINTERS, PHOTOCOPIERS ETC.

**DO NOT USE AS A TEMPLATE
 THIS IS FOR REFERENCE ONLY**
 (SEE NOTE 3)

Description:	Deck Cutout Details 3000 3500 4000 VW	Drawing No:	4305	Revision No:	3.00
Material:	N/A	Sheet Size	A3	Scale	1:1
Tolerances: If none specified		Sheet			
0 DECIMAL (X)	± 0.5	1 of 1			
1 DECIMAL (X.X)	± 0.2				
2 DECIMAL (X.XX)	± 0.1				

APPENDIX B – Spare Parts – Topworks

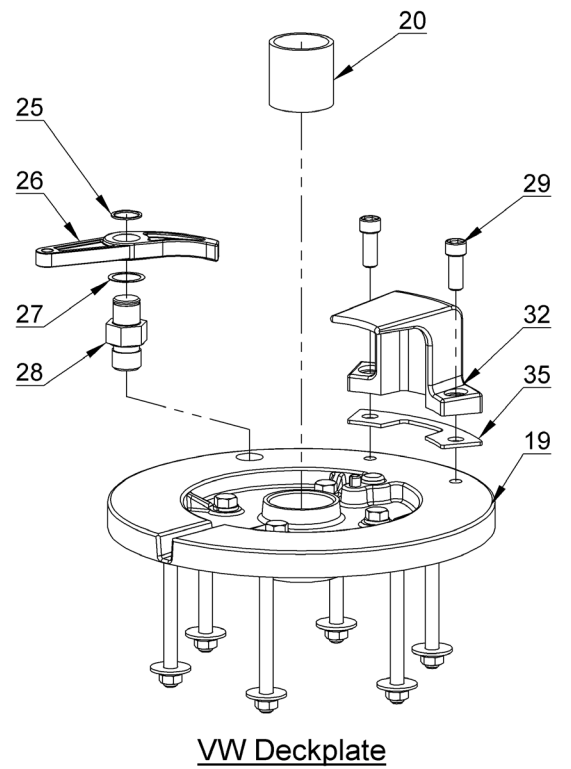
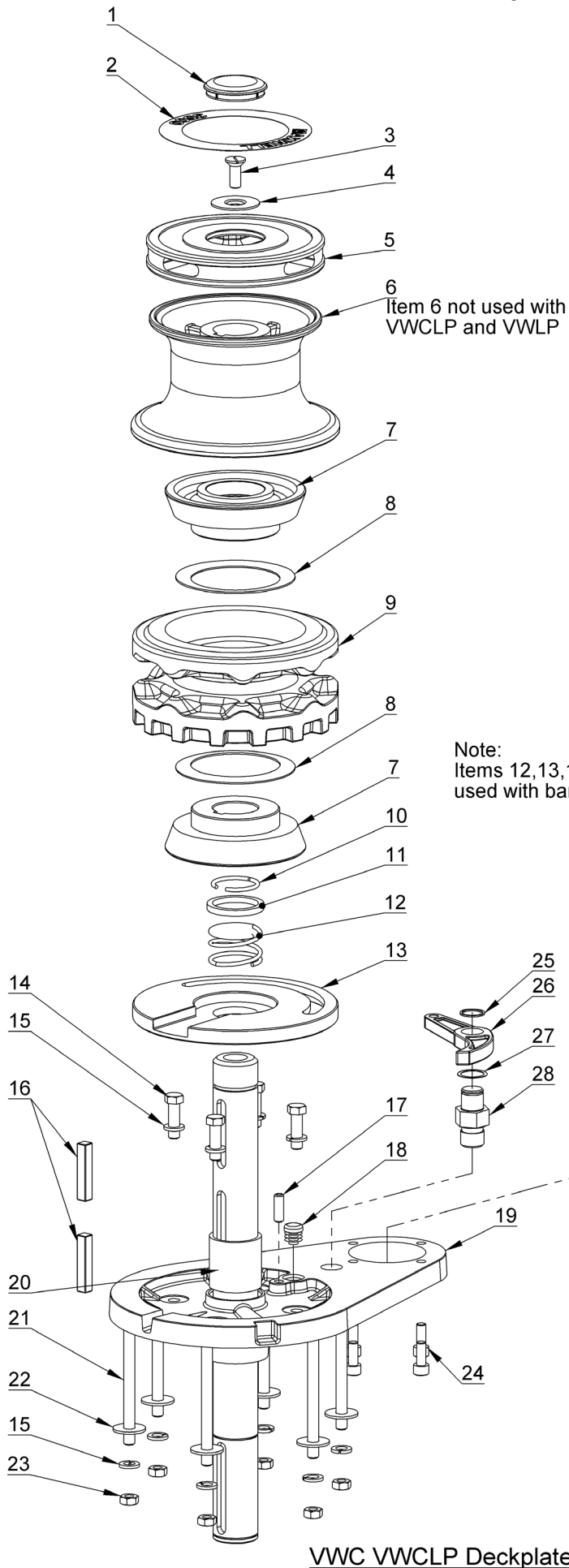

Note:
Items 12, 13, 17, 25, 26 and 27 are not used with band brake versions

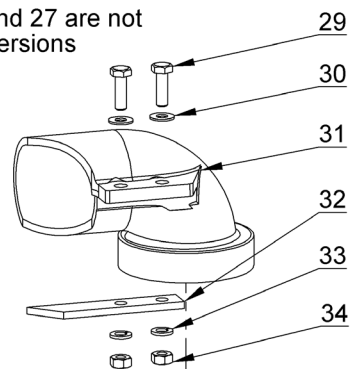

Item	Description	Qty	Part No.
1	Cap	1	3227
2	Label	1	3856
3	Screw – Csk 3/8 x 1” stainless steel	1	SP0040
4	Retaining Washer	1	3267
5	Clutch Nut	1	3181C
6	Drum VW VWC, VWCLP	1 1	4288C 2304C
7	Clutch cone	2	6061
8	Disc spring	2	5953
9	Chainwheel Non band brake version Band brake version	1 1	3182C 5437C
10	Retaining clip	2	2311
11	Washer – Non-band brake versions Seal – Band brake versions	1 1	7068 SP0740
12	Spring – Non-band brake versions	1	2310
13	Emergency crank collar – Non-band brake versions	1	3158
14	Hex Hd. Bolt – M10x35 stainless steel	4	SP3221
15	Spring washer – M10 stainless steel	10	SP0466
16	Keys – VWC, VW VWCLP, VWLP	2 1	3207 3207
17	Pin – Non-band brake versions	1	SP0544
18	Plug	1	SP0875
19	Deckplate VWC, VWCLP VW, VWLP	1 1	1506C 4279C
20	Bearing	1	SP0657
21	Stud 85 TDC 190 TDC	6 6	7652 7482
22	Washer – Flat – 28 x 10 x 2 stainless steel	6	3843
23	Nut – M10 stainless steel	6	SP0371
24	Cap screws M8 x 20 stainless steel	4	SP0167
25	Retaining Ring – Non-band brake versions	5	SP0871
26	Pawl – Non-band brake versions	1	2324
27	Wavy washer – Non-band brake versions	1	SP0463
28	Pawl Pin	1	3435
29	Cap screws M10 x 25 stainless steel – VW, VWLP Hx. Hd Bolts M8 x 25 stainless steel – VWC, VWCLP	2 2	SP0166 SP0288
30	Flat washer – M8 stainless steel	2	SP0428
31	Chainpipe Clockwise configuration Anticlockwise configuration	1 1	3191C 3192C
32	Stripper VWC VWCLP VW	1 1	6980 4278C
33	Spring washer – M8 stainless steel	2	SP0467
34	Hex. Hd. Nut – M8 stainless steel	2	SP0366
35	Spacer	1	5671

Spare Parts – Bottomworks

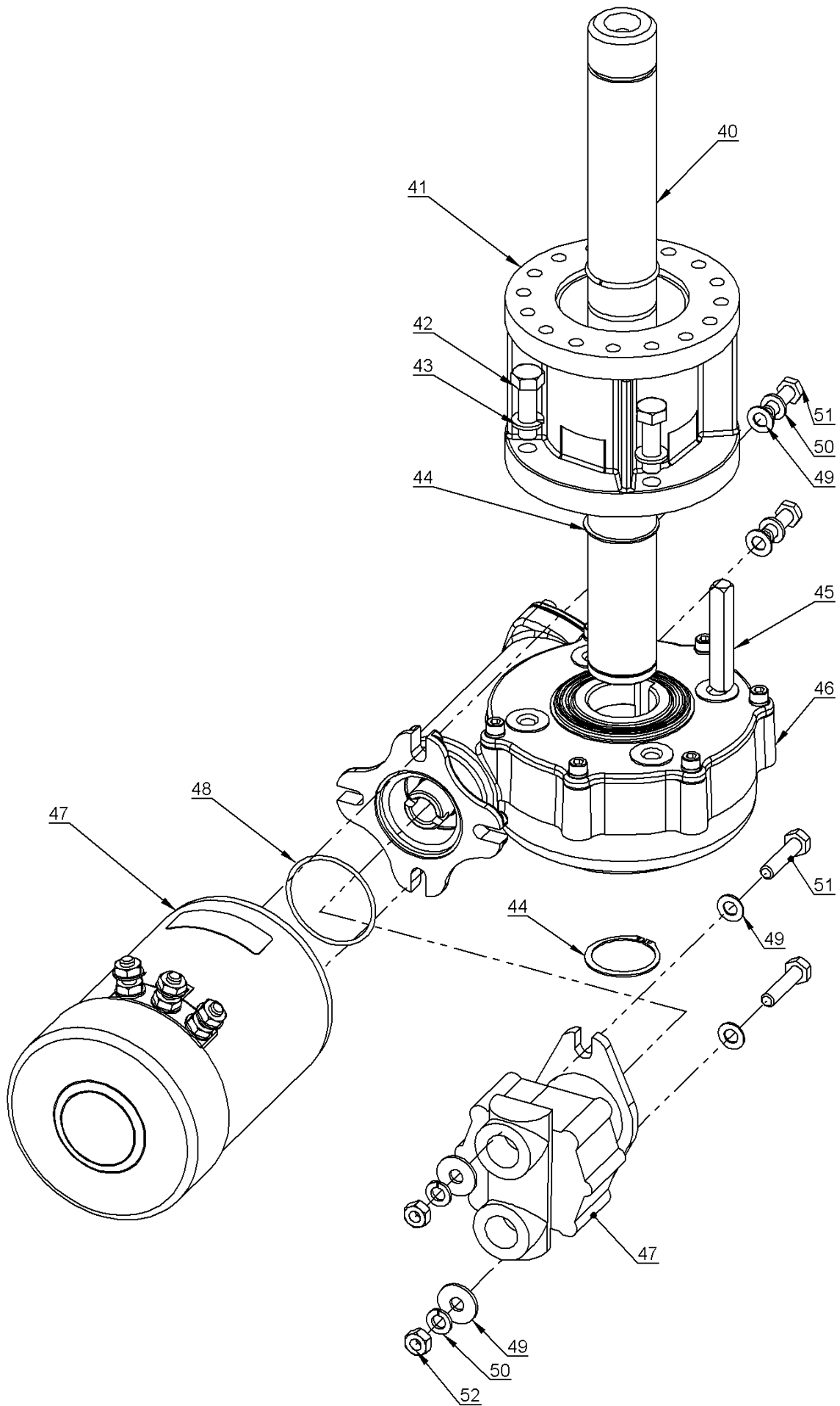

Item	Description	Qty	Part No.
40	Mainshaft		
	VWC	1	3171
	VWC 100mm extra deck clearance	1	3219
	VW	1	4287
	VWLP, VWCLP	1	3206
	VWCLP 100mm extra deck clearance	1	3218
41	Spacer tube		
	Standard deck clearance	1	7433
	100 extra deck clearance	1	7434
42	Hex Bolt M10 x 35	4	SP3221
43	Spring Washer M10	4	SP0466
44	Circlip	2	SP0846
45	Key	1	3150
46	Gearbox	1	P102181
47	Motor		
	12V DC	1	P11165
	24V DC	1	P11166
	Hydraulic	1	P14368
48	Motor Bolt Kit – DC Motor – consists of:	1	P12487
	O-Ring	2	SP0288
49	Flat washer	2	SP0467
50	Spring washer – M8 stainless steel	2	SP0413
51	Hx. Hd Bolts M8 x 25 stainless steel	1	SP2787
	Motor Bolt Kit – Hydraulic Motor – consists of:	1	P12488
49	Flat washer	2	SP0279
50	Spring washer – M8 stainless steel	4	SP0413
51	Hx. Hd Bolts M8 x 30 stainless steel	2	SP0467
52	Hex. Hd. Nut – M8 stainless steel	2	SP0366

Spare Parts – Band Brake

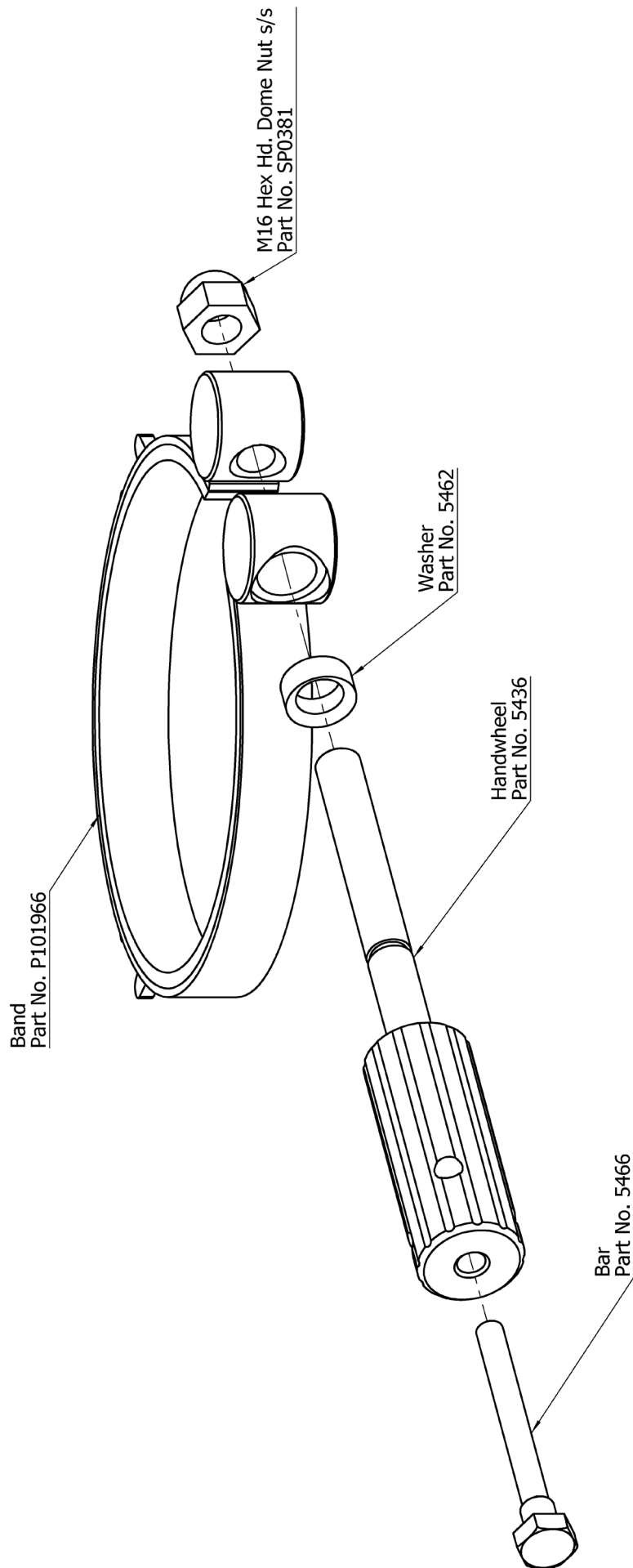

APPENDIX C – Installation Schematics

This drawing is protected by copyright and the design and or details contained therein are the intellectual property of Maxwell Marine Ltd. This drawing must be returned upon demand and must not be copied, leased or have its contents communicated to any other persons, including subcontractors, without the consent in writing from Maxwell Marine Ltd. This drawing must not be used for any other purpose other than that for which it was originally supplied.

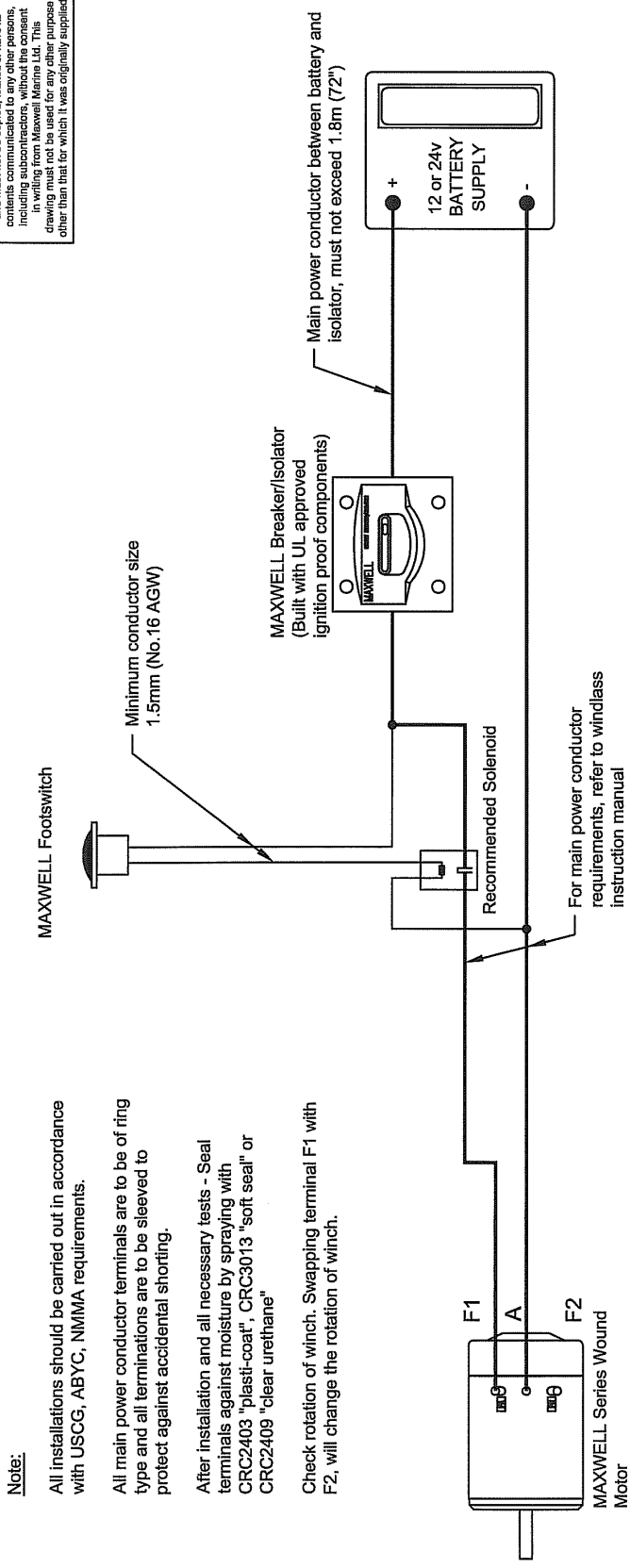

Note:
 All installations should be carried out in accordance with USCG, ABYC, NIMMA requirements.
 All main power conductor terminals are to be of ring type and all terminations are to be sleeved to protect against accidental shorting.
 After installation and all necessary tests - Seal terminals against moisture by spraying with CRC2403 "plasticoat", CRC3013 "soft seal" or CRC2409 "clear urethane"
 Check rotation of winch. Swapping terminal F1 with F2, will change the rotation of winch.

Rev.	Change	Made On	Des/Drawn	Checked	BV7/Dwg No.	Description	Assy No.
1.00	Initial Issue	21/7/04	D/RP		N/A	Wiring Diagram - Typical For Single Direction Series Wound Motor	P101844
2.00	Removed permanent magnet motor	24/1/08	RP	JE	BVT View		
					N/A		
					Sheet Size		
					A4		
					Scale		
					NTS		
					Sheet 1 of 1		

This drawing is protected by copyright and the design and/or details contained therein are the confidential property of Maxwell Ltd. This drawing must be returned, amended and must not be copied, loaned or have its contents communicated to any other persons, including subcontractors, without the consent in writing from Maxwell Marine Ltd. This drawing must not be used for any other purpose other than that for which it was originally supplied.

Note:
 All installations should be carried out in accordance with USCG, ABYC, NMMA requirements.
 All main power conductor terminals are to be of ring type and all terminations are to be sleeved to protect against accidental shorting.
 After installation and all necessary tests - Seal terminals against moisture by spraying with CRC2403 "plasti-coat", CRC3013 "soft seal" or CRC2409 "clear urethane"
 Check rotation of winch before application of chain/rope. Swapping F1 and F2 terminals or connection 1 and 3 on solenoid box will change the rotation of winch.

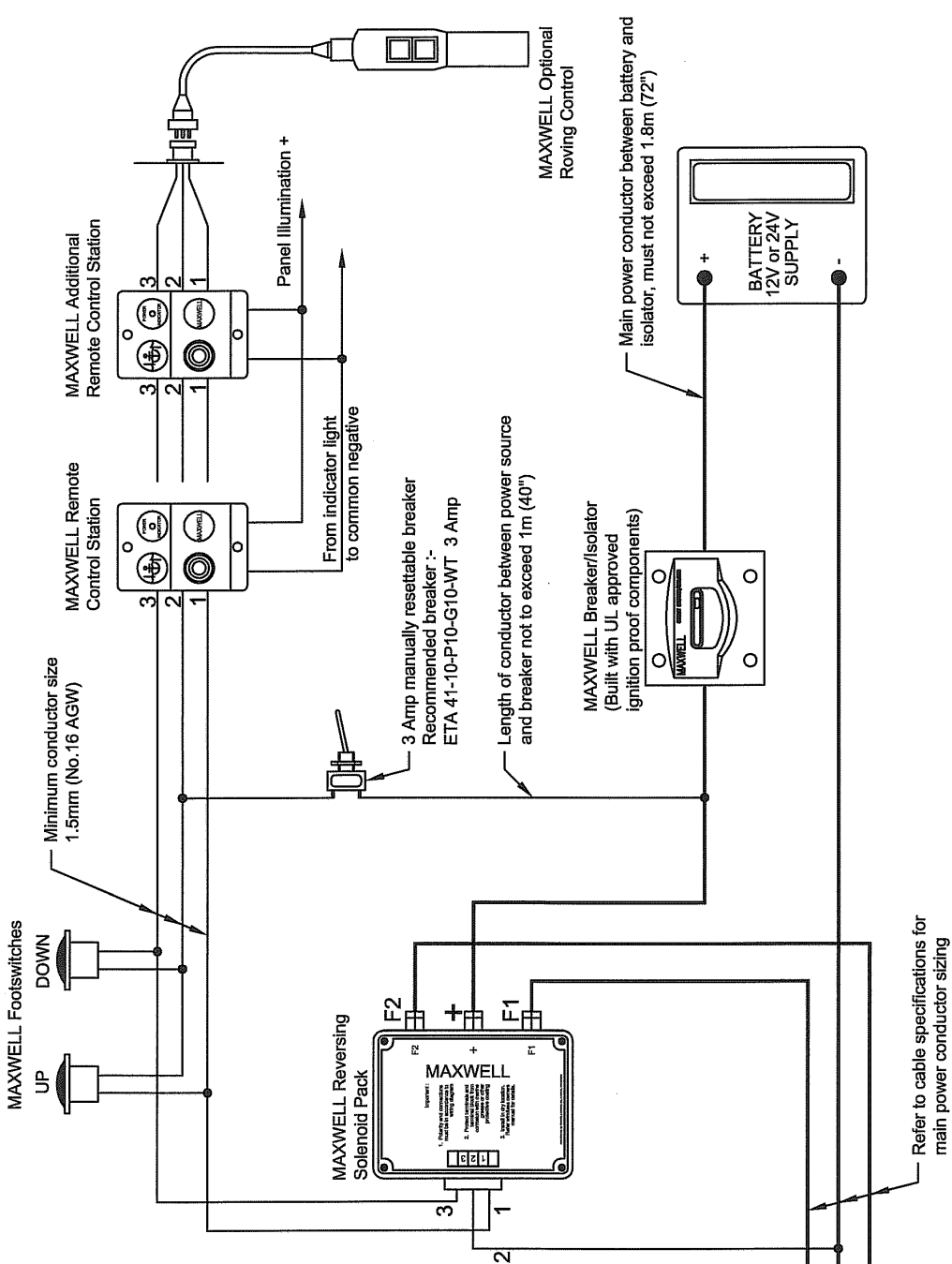

Revision	Change	Made On	Des/Drawn	Checked	BVT/Dwg No.	Description	Assy No.
1.00	Initial Issue	21/7/2004	D/IRP	GB	N/A	Wiring Diagram - Typical For Series Wound Motors	P101840
2.00	Terminal 3 routing from solenoid box corrected	25/05/2005	RP	GB	BVT View		
					N/A		
					Sheet Size		
					A4		
					Scale		
					NTS		
					Sheet 1 of 1		

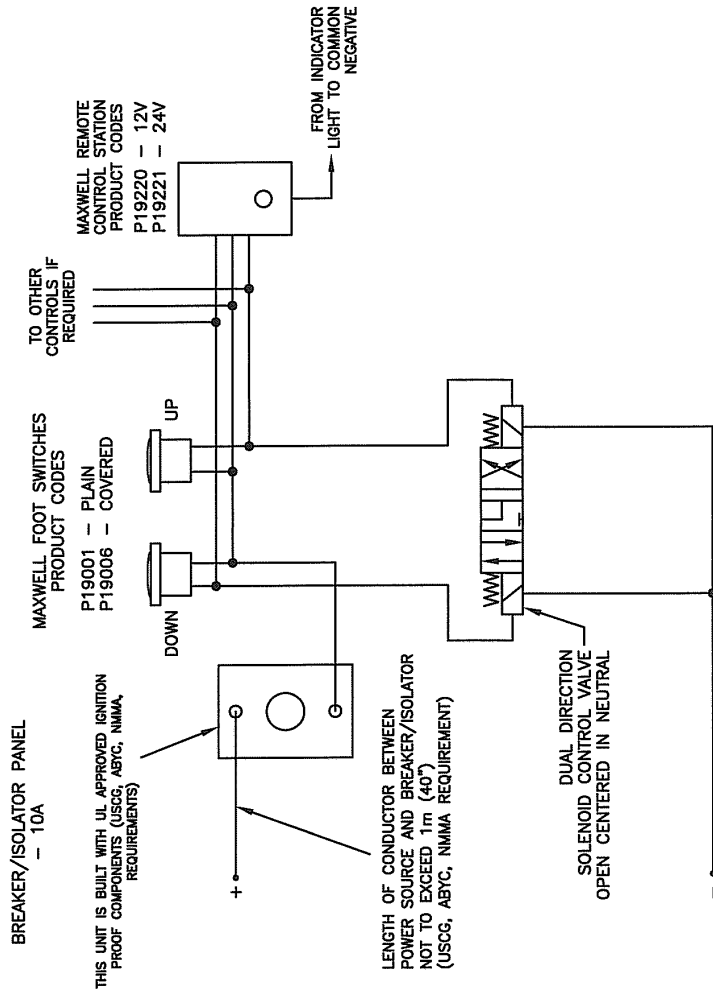

ALL INSTALLATIONS SHOULD BE CARRIED OUT IN ACCORDANCE WITH USCG, ABYC, NMMA, OR CLASSIFICATION SOCIETY REQUIREMENTS.

MINIMUM CONDUCTOR SIZE 1.5mm² (AWG 16)
(USCG, ABYC, NMMA REQUIREMENT)

Rev.	Description	Date	Name	Checked
3.00	Removed clutch relay	29/04/03	DRW	
4.00	Control Station Codes corrected	07/06/07	RP	JE

ELECTRIC CONTROL WIRING DIAGRAM FOR HYDRAULIC WINDLASSES

MAXWELL WINCHES LTD.
AUCKLAND NEW ZEALAND

P101821

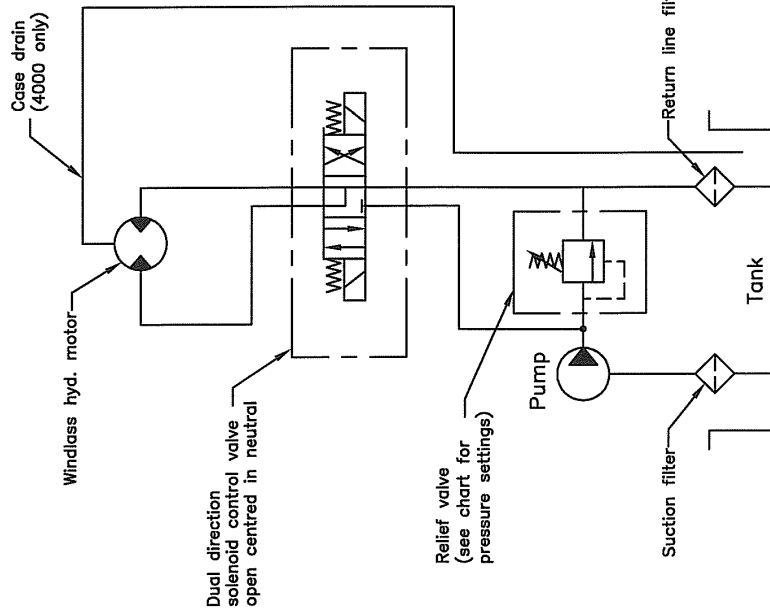

Series	Windlass		Recommended flow		Relief valve pressure setting	
	Motor		l/min	US gal/min	PSI	bar
1000	GRESEN MGG2-16		20	5.3	1450	100
1500	GRESEN MGG2-16		20	5.3	2000	138
2200	GRESEN MGG2-30		36	9.5	1800	124
2500	GRESEN MGG2-25		32	8.5	2000	138
Liberty	GRESEN MGG2-25		32	8.5	2000	138
3500	GRESEN MGG2-25		40	11	2000	138
4000	Galtech 2SM-A-19		50	13.2	1500	103

Chart refers to MAXWELL "standard build". Lower flow or lower pressure can be accommodated - refer to manual or consult MAXWELL.

Ensure that selected hydraulic components are adequate for recommended flow rate.

Case drain can only connect to return line if return line pressure is below 25 PSI. Otherwise case drain must connect to tank

Revision	Description	Date	Name
7.00	Removed pressure switch, Added liberty	29/04/03	DRW
8.00	Directional control valve changed back	22/10/04	JE
9.00	4000 motor changed from SP2224 to SP2250	20/03/07	JE
HYDRAULIC SCHEMATIC WINDLASSES 1000 - 4000			
MAXWELL WINCHES LTD. AUCKLAND NEW ZEALAND			
P101820			

LIMITED WARRANTY

Warranty: Vetus-Maxwell APAC Ltd provides a three year limited warranty on windlasses for pleasure boat usage, and a one year limited warranty for those systems used on commercial or charter vessels. Warranty, service and parts are available around the world. Contact your nearest Vetus-Maxwell office for a complete list of service centres and distributors.

This warranty is subject to the following conditions and limitations:

1. This Warranty will be null and void if
 - (a) there is any neglect or failure to properly maintain and service the products.
 - (b) the products are serviced, repaired or maintained improperly or by unauthorised persons.
 - (c) loss or damage is attributed to any act, matter or omission beyond the reasonable control of Vetus-Maxwell or the purchaser.
2. Vetus-Maxwell APAC Ltd liability shall be limited to repair or replacement (as determined by Vetus-Maxwell) of the goods or parts defective in materials or workmanship.
3. Determination of the suitability of the product and the materials for the use contemplated by the buyer is the sole responsibility of the buyer, and Vetus-Maxwell shall have no responsibility in connection with such suitability.
4. Vetus-Maxwell shall not be liable for any loss, damages, harm or claim attributed to:
 - (a) use of the products in applications for which the products are not intended.
 - (b) corrosion, wear and tear or improper installation.
 - (c) improper use of the product.
5. This Warranty applies to the original purchaser of the products only. The benefits of the Warranty are not transferable to subsequent purchasers.
6. Vetus-Maxwell shall not be responsible for shipping charges or installation labour associated with any warranty claims.
7. There are no warranties of merchantability, fitness for purpose, or any other kind, express or implied, and none shall be implied by law. If any such warranties are nonetheless implied by law for the benefit of the customer they shall be limited to a period of three years from the original purchase by the user.
8. Vetus-Maxwell shall not be liable for consequential damages to any vessel, equipment, or other property or persons due to use or installation of Vetus-Maxwell equipment.
9. This Warranty sets out your specific legal rights allowed by Vetus-Maxwell APAC Ltd ; these may be varied by the laws of different countries. In addition, the purchaser may also have other legal rights which vary from country to country.
10. To make a claim under this Warranty, contact your nearest Vetus-Maxwell or distributor. Proof of purchase and authorisation from Vetus-Maxwell will be required prior to any repairs being attempted.



To be eligible for warranty protection, please either complete the form below at the time of purchase and return it to the appropriate retailer or supplier of the goods, or fill out the electronic Warranty Form on our website, www.maxwellmarine.com

Purchaser

Name:

Address:

Telephone:

Facsimile

Supplier / Dealer

Name:

Address:

Telephone:

Facsimile

Windlass Model

Serial Number

Date of Purchase

Boat Type

Windlasses Supplied

Name

L.O.A.

With boat

Fitted by boat yard/dealer

Purchased from dealer/chandler

Built by



