



**TYPE R REMOTE DRIVE
FOR AUXILIARY
KICKER MOTORS**

INSTALLATION MANUAL

OC15374

Revision History

Revision	Description
NEW	First Edition
A	Second Edition
B	Updated per CMP DCR # 2462
C	Third Edition

© 2013 Canada Metal (Pacific) Limited. All rights reserved.

The information contained in this document is the sole property of Canada Metal (Pacific) Limited. Any reproduction in part or whole without the written permission of Canada Metal (Pacific) Limited is prohibited. Canada Metal (Pacific) Limited will not be liable for errors contained herein or for incidental or consequential damages in connection with the furnishing, performance or use of this document.

To the best of our knowledge, the information in this document was correct at the time it was produced. However, Canada Metal (Pacific) Limited cannot accept liability for any inaccuracies or omissions it may contain. In addition, our policy of continuous product improvement may change specifications without notice. As a result, Canada Metal (Pacific) Limited cannot accept liability for any differences between the product and this document. Please visit www.intellisteer.com to ensure you have the most up-to-date version of the documentation for your product.

CONTENTS

A	Introduction	
A1	System Overview	4
A2	Maximum Trolling Speed	4
B	Mechanical Installation	
B1	Available Space - Physical Envelope & Orientation	5
	<i>B1a Drive Installation</i>	6
B2	Connection To Kicker Motor	7
	<i>B2a Compatibility</i>	7
	<i>B2b Supplied Parts</i>	7
	<i>B2c Installation</i>	7
B3	Routing Steering Cable	11
	<i>B3a Cable Length Calculation</i>	11
B4	Connecting Steering Cable To Drive	12
B5	Electrical Installation	13
B6	Interference Evaluation	13
C	Appendix	
C1	Accessories	14
C2	General Maintenance Guide	14

A INTRODUCTION

A1 System Overview

The Intellisteer Type R Remote Drive is a mechanical steering drive designed to work in conjunction with the Intellisteer Wireless Steering System on smaller powerboats fitted with an auxiliary kicker motor.

The Type R drive unit incorporates a drive motor and solenoid clutch; its compact design provides flexibility in selecting a suitable mounting location.

The system uses a steering cable which is fitted directly to the kicker motor via a connection kit. This allows the system to be easily installed on most types of auxiliary kicker motors. The Type R pack includes the drive unit and a 6ft (1.8m) steering cable. The relevant connection kit/steering link arm is available from the kicker motor manufacturer.

A2 Maximum Trolling Speed

The Type R Drive is recommended for use at trolling speeds only.

B MECHANICAL INSTALLATION

B1 Available Space - Physical Envelope & Orientation

The selected installation site should provide adequate space to accommodate the drive unit including the entry and exit points for the steering cable. The drive can be mounted at any angle. Note that no access for maintenance purposes is required. The steering cable entry and exit ports are reversible, so the cable entry and exit ports can be selected for the best installation arrangement on the particular vessel.

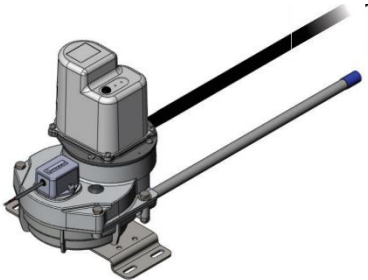

HORIZONTAL MOUNT

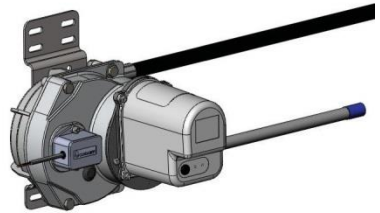

VERTICAL MOUNT

Fig B1 - Mounting options

NOTE: If the ports are reversed, the steering action will also be reversed. This can be compensated for by reversing the drive motor wiring connection to the IntelliSteer Wireless Receiver.

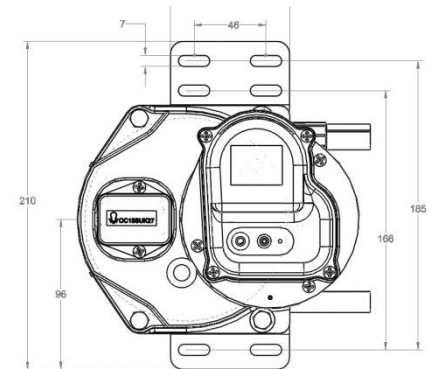
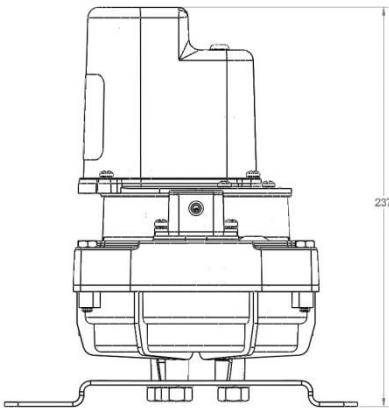

BASEPLATE PERPENDICULAR MOUNT

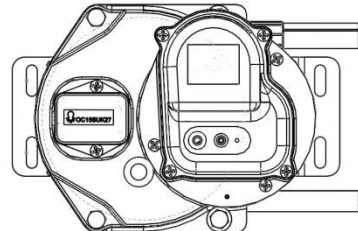

BASEPLATE PARALLEL MOUNT

Fig B2 - Physical drive envelope

B1a Drive Installation

The design of the Type R Drive System gives a high degree of flexibility in the location of the drive unit relative to the steering mechanism, however factors such as the optimum steering cable route and also the length of the steering cable (6ft / 1.8m standard, other lengths available) will influence the final location.

It is recommended that the steering cable/drive unit connection is made before the drive unit is firmly attached to the hull structure, but it is advisable to take into account the points raised in section B3 regarding steering cable routing when planning the drive unit location.

- i) Position the drive unit in the final location. Verify that there is sufficient clearance for the steering cable entry and the spent cable tube, as well as access for the electrical connections.
- ii) Although there are no loads transferred to the drive unit mounting when the wireless controller is in operation, the selected location should be sturdy enough to support the drive unit.
- iii) The drive base plate can be fitted in two possible orientations - perpendicular or parallel. Assemble the base plate to the drive using the most suitable orientation for the installation and torque the fasteners to 30-35in-lb (3.4-4.0Nm).
- iii) Mark out the fixing pattern from the drive base plate and drill appropriate sized pilot holes into the mounting structure (Fig B3). The mounting holes are suitable for ¼in or 6mm fasteners.
- iv) Position the drive unit and install using suitable fasteners. Ensure they are tightened securely.

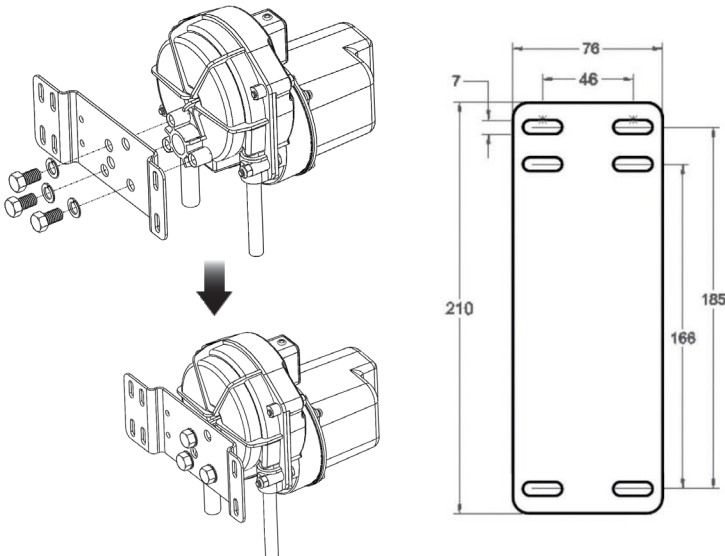

Fig B3 - Mounting plate drilling dimensions

B2 Connection To Kicker Motor

B2a Compatibility

The Type R drive is compatible with most kicker motors that include a tilt tube. The steering cable is fitted through the tilt tube and is linked to the motor full size tilt tube using a steering link arm connection kit available from the kicker motor manufacturer.

B2b Supplied Parts

Type R	Remote Rotary Drive Unit
OC15109-6	6ft (1.8m) Steering Cable*

* Other lengths are available as optional accessories

B2c Installation

Presented here is an example of the connection of the Type R steering cable to a Mercury 8hp kicker motor using the Octopus Steering Link Arm connector kit OC15SUK31B or OC15SUK31A (depending on which side the kicker motor is mounted). Installation on other kicker motors and using other Steering Link Arm connector kits will be similar.

- Prepare the engine mounting site
 - i) Ensure that there is sufficient space around the kicker motor for the installation and there are no obstructions that may interfere with the fitting and operation of the steering cable.
 - ii) Lubricate the inside of the tilt tube with marine quality grease before assembly (Fig B4).

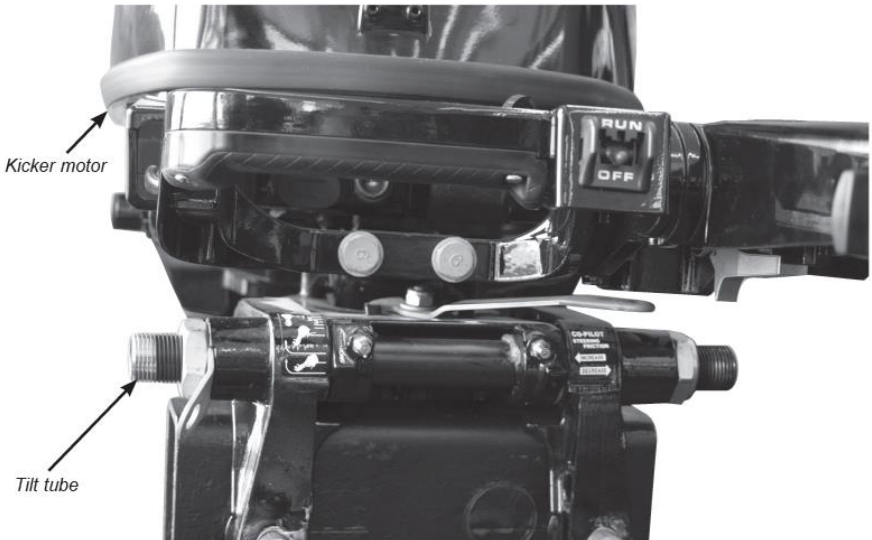

Fig B4 - Kicker motor mounting bracket with tilt tube

- Fit the steering link arm to the kicker motor
 - i) Remove the two bolts from the steering link arm mounting point on the front of the kicker motor.
 - ii) Attach the steering link arm bracket to the kicker motor (Fig B5).
 - iii) Replace the bolts. Ensure they are tightened securely.

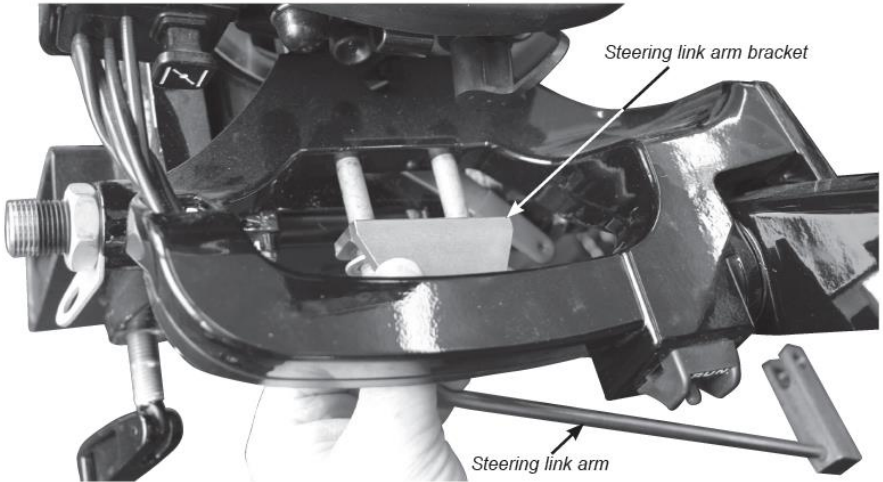

Fig B5 - Fitting the steering link arm to the kicker motor

- Attach the steering cable to the tilt tube
 - i) Insert the rod end of the steering cable into the tilt tube (Fig B6).

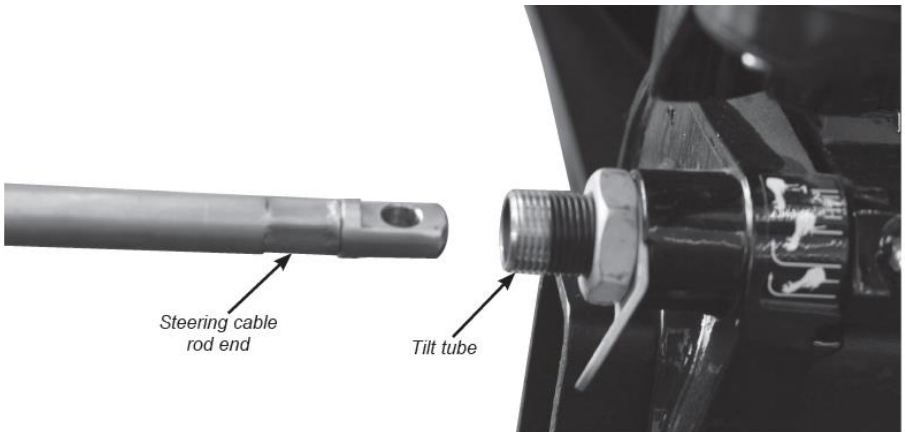

Fig B6 - Inserting the steering cable into the tilt tube

- ii) Hand-tighten the cable nut (Fig B7) and torque to 175in-lb (20Nm). The nut has an internal locking thread which increases the amount of torque required initially as the thread is cut.

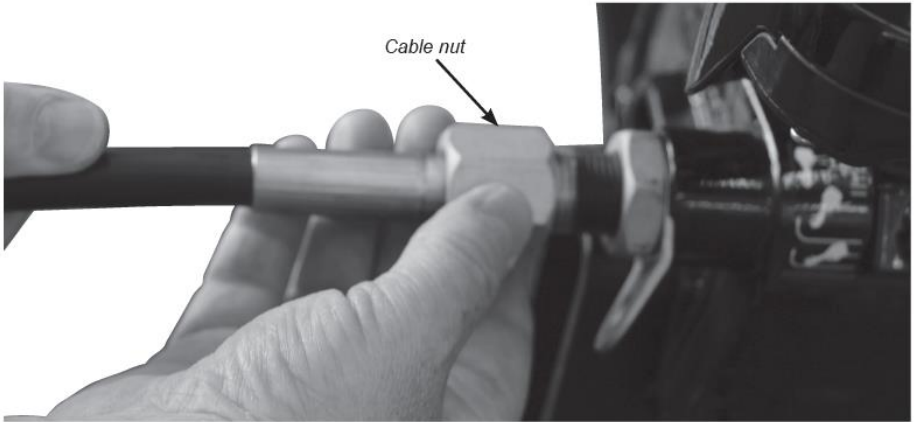

Fig B7 - Tightening the steering cable nut

- Fit the steering link arm to the steering cable.
 - i) The steering link arm is bolted through the hole in the end of the steering cable rod end (Fig B8). Tighten and torque to 180-200in-lb (20-22.5Nm).

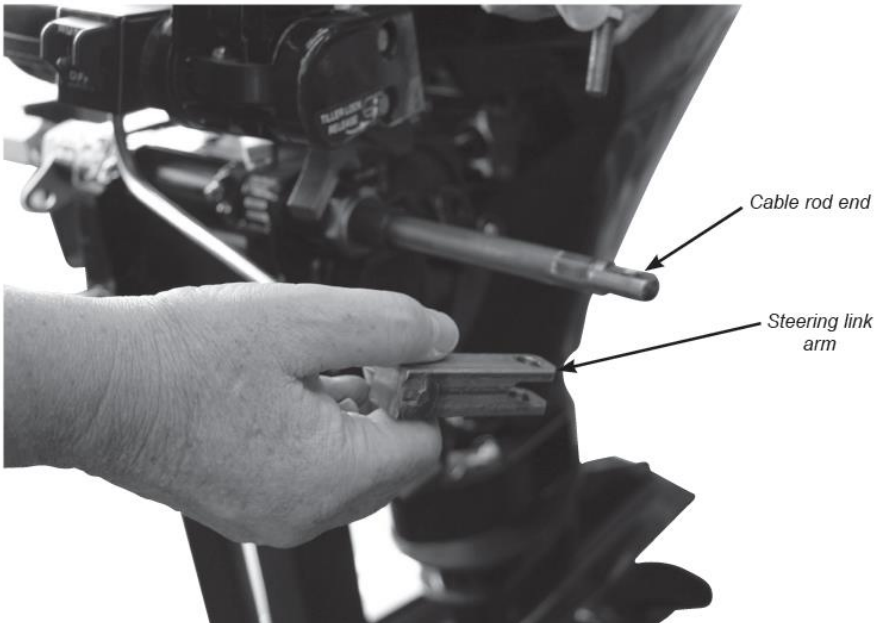

Fig B8 - Attaching the steering link arm to the steering cable

- Refer to section B4 on connecting the steering cable to the drive unit.

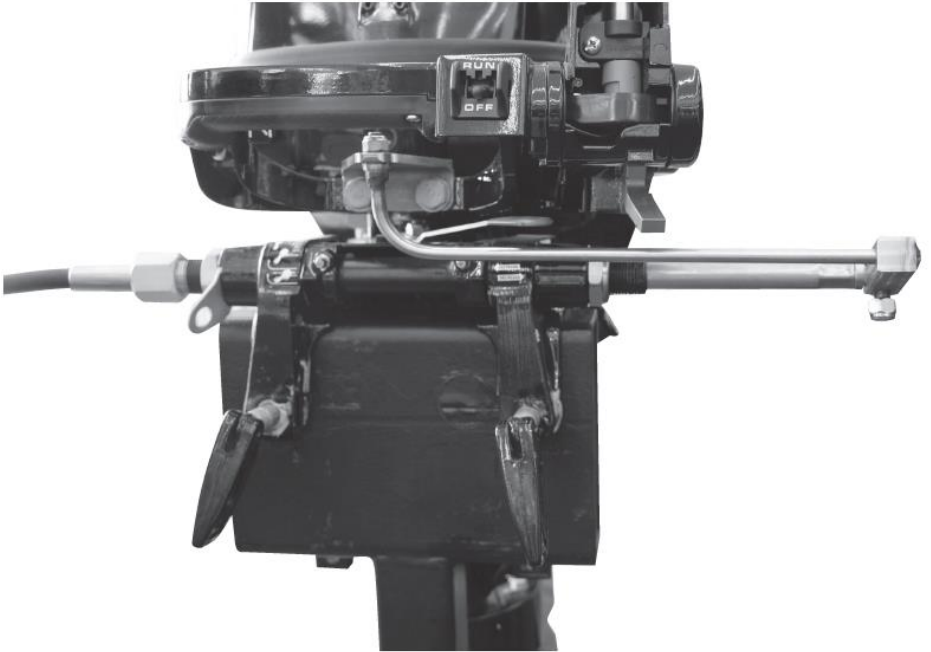

Fig B9 - Completed assembly

B3 Routing Steering Cable

When deciding on the routing path for the Type R drive steering cable, consideration must be given to the following points:

- i) Ensure that no part of the cable is under stress at any point of steering, otherwise damage to the cable may result over long term usage.
- ii) The chosen route should use the minimum possible number of bends.
- iii) If any bends are necessary, maximise the bend radius as much as possible. It is recommended that bends have a radius of no less than 6in (150mm) and that the combined total angle of all bends is no more than 270°.

B3a Cable Length Calculation

All Type R Drive System Packs are supplied as standard with a 6ft (1.8m) steering cable, which should be suitable for most installations. If a suitable location for mounting the drive unit is not available using this cable then other lengths are available as separate accessories.

Use a length of rope or electrical cable to plan out the steering cable route and then measure the total length required (Fig B10) :

(‘A’ Dimension + ‘B’ Dimension) – 4in for a 90° bend

Round up the result to the nearest full foot size and then refer to section D1 for the appropriate custom cable order code.

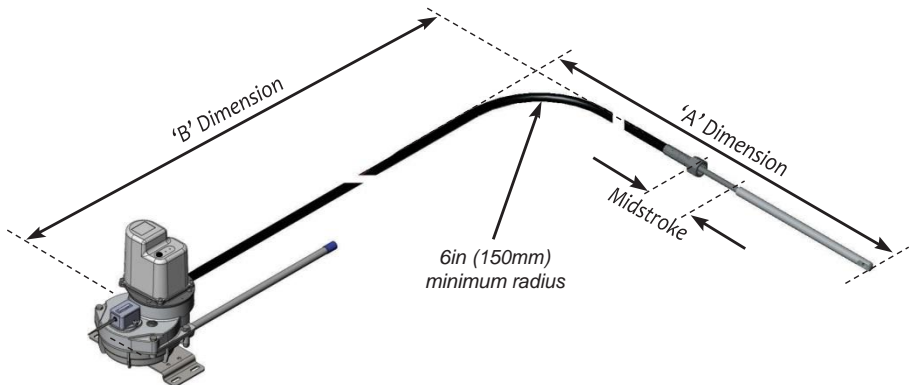

Fig B10 - Preferred cable routing

B4 Connecting Steering Cable To Drive

Either port can be used for the steering cable entry - select the most convenient for the installation.

- i) Remove the lock bolts, nuts and washers from both ports (Fig B11).
- ii) Insert the steering cable into the drive port. Using moderate force, guide the inner cable around the driving hub and out of the opposite port.
- iii) Push the steering cable jacket into the port until the retaining collar butts against the drive housing (Fig B12). If required, the cable can be "driven" into the drive by powering up the clutch and drive.

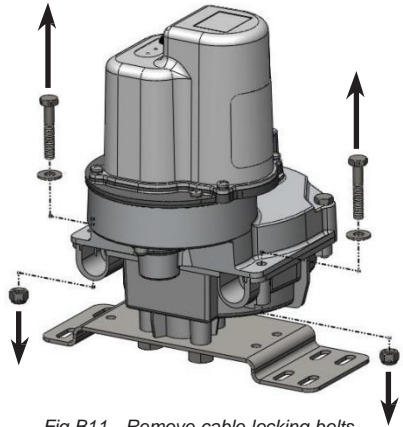

Fig B11 - Remove cable locking bolts

- iv) Insert the lock bolt to hold the cable in place.
- v) If undue force is required to insert the cable, this may be caused by the end of the inner cable fouling the outer face of the nylon guide. If this is the case, remove the cable and inspect for sharp edges. If possible, twist the cable so that the sharp edge is towards the inside of the radius, or use a file or burr type tool to remove the sharp edges.
- vi) Fit the spent cable tube to the opposite port and insert the lock bolt.
- vii) Fit washers & nuts to both lock bolts, tighten & torque to 40-45in-lbs (4Nm).

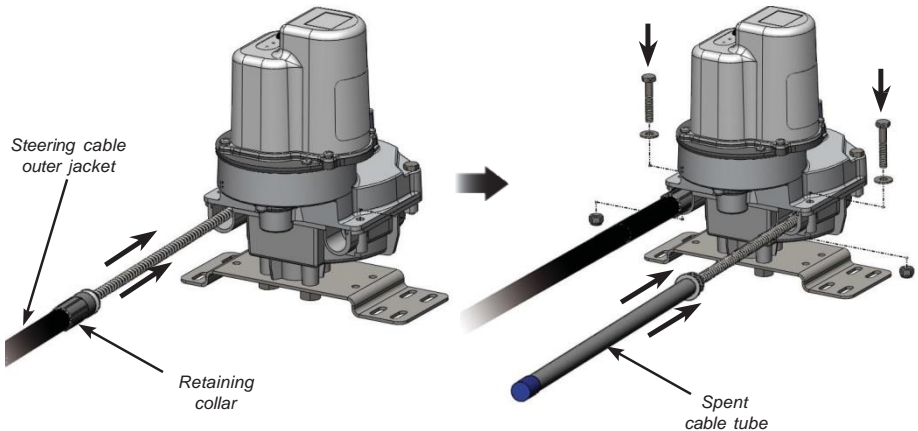

Fig B12 - Fitting steering cable and spent cable tube

B5 Electrical Installation

Refer to the separate installation instructions supplied with the IntelliSteer Wireless Controller.

Remote receiver Wire color	MDR Wire color	Description
Blue	Red*	Motor Drive
Green	Black	
Orange	White	Motor Clutch
Purple	Green	
Red	n/a	Power 12V+
Black	n/a	Power 0V-
Yellow	n/a	Course Computer Drive Output +
Yellow/Green	n/a	Course Computer Drive Output -
Brown	n/a	Course Computer Clutch 1
Grey	n/a	Course Computer Clutch 2

*Red is standard color. However, it may look like pink due to variation in manufacture.

Note: For a standalone drive installation, the four Course Computer Wires (Yellow, Yellow/Green, Brown and Grey) are not used, and should be wrapped with electrical tape and secured.

B6 Interference Evaluation

It is vital that an operating clearance check is performed between the steering cable and the existing hardware including hoses, electrical cables and control cables before the system is connected to the wireless controller or the boat is taken to sea.

- i) While operating the Type R drive from full lock to full lock, observe the kicker motor movement and ensure that there is no physical interference between any parts across the full steering lock.
- ii) With the kicker motor set to full lock left, tilt the kicker to the full up position and ensure that there is no physical interference between the parts at any stage. Repeat this procedure with the kicker motor set to full lock right.
- iii) It may be necessary to reroute hoses, electrical cables, control cables or other hardware to avoid interference during operation. All hardware must be well clear of the kicker motor fitting kit and steering cable. Chafing may occur if parts are permitted to come into contact.

C APPENDIX

C1 Accessories



OC15109-6	Standard Steering Cable x 6 foot long
OC15109-9	Standard Steering Cable x 9 foot long
OC15109-12	Standard Steering Cable x 12 foot long

OC15SUK31A Steering Link Assy - Mercury 9.9 STBD Kit

OC15SUK31B Steering Link Assy - Mercury 9.9 PORT Kit

C2 General Maintenance Guide

- Grease the tilt tube by applying a grease gun to the grease nipple after installation and at regular intervals thereafter.
- Check the complete steering system and all fixings for security and integrity after a few hours of operation and at frequent intervals.
- Keep all moving parts free from build-up of salt and other foreign material - this will adversely affect their operation and create steering problems. Pay particular attention to the installation kit hardware.
- Inspect all parts periodically for corrosion. Any parts affected by corrosion must be replaced.
- Periodically remove the cable, clean the tilt tube and thoroughly lubricate with a waterproof grease. Inspect the cable for cracks, splits or other damage. **DO NOT** cover cracks in the cable outer sheath with tape or other sealant; this will only delay a failure of the cable. Always replace the cable.
- When replacing fixings, self-locking nuts must always be used.
- The cable is a consumable item which should be replaced at regular intervals. It is recommended that the cable is replaced after 150-200 hours of use or every two seasons. Note that incorrect installation, high torques or lack of maintenance will reduce the life of the cable.

IntelliSteer

W I R E L E S S S T E E R I N G

IntelliSteer® is a registered trade mark of Canada Metal (Pacific) Ltd.

7733 Progress Way, Delta, BC, Canada, V4G 1A3

Tel: 1 (604) 940-2010 Fax: 1 (604) 952-2650

Web: www.intellisteer.com E-mail: octopus@canmet.com