

HARKEN®

REFLEX™ FURLING

Unit 1, 2

Installation Manual – Intended for specialized personnel or expert users

5106 05-16



Asymmetric spinnaker furler



Code zero furler

Table of contents

Preassembly

Introduction and safety precautions	2
Part descriptions - terms	2-3
Size check	3
Asymmetric spinnaker furler parts	4
Code zero furler parts	5
Additional parts required - tools	6
Dimensions - sailmaker's instructions	7
Cable length worksheet	8

Assembly

Threaded adapter	9
Terminating torsion cable to head swivel	10-12
Terminating cable to tack terminal - away from boat	12
Alternate at boat - cable length	13
Alternate at boat - cutting cable and final assembly	14-15

Commissioning

Loading furling line in drive unit	16
Mounting fairleads - line to cockpit	17
Attaching sail to unit	18

Operation

Hoisting sail first time - halyard tension	18
Asymmetric spinnaker furling	19
Code zero furling	20
Lowering sail/hoisting furled sail - sail changes	21
Sail changes	22

Maintenance

Cleaning parts and bearing assemblies	23
---------------------------------------	----

Warranty and contact information	24
---	-----------

Please read these instructions carefully before installing, servicing, or operating the equipment.
This manual may be modified without notice. See: www.harken.com/manuals for updated versions.

PLEASE SAVE THESE INSTRUCTIONS

This manual gives technical information on installation and service. This information is **destined exclusively** for specialized personnel or expert users. Installation, disassembling, and reassembling by personnel who are not experts may cause serious damage to property or injury to users and those in the vicinity of the product. If you do not understand an instruction contact Harken.

The user must have appropriate training in order to use this product.

Harken accepts no responsibility for damage or harm caused by not observing the safety requirements and instructions in this manual. See limited warranty, general warnings, and instructions in www.harken.com/manuals.

Purpose

The Harken Reflex™ furling system for asymmetric spinnakers is used for handling free-flying downwind and reaching sails. These sails have a loose positive luff that is longer than the leech and are called asymmetric spinnakers, cruising spinnakers, or gennakers. The furling system is also for code zero straight-luffed sails. Attachment methods vary according to sail type. Use of this product for other than normal sailboat applications is not covered by the limited warranty.

Safety Precautions



WARNING! Strictly follow all instructions to avoid potential hazards that may kill or hurt you and others. See www.harken.com/manuals for general warnings and instructions.

Part Descriptions

- 1) Head swivel
- 2) Torsion cable clamps
- 3) Heat shrink tube
- 4) Reflex torsion cable
- 5) Tack swivel terminal
- 6) Fixed tack terminal
- 7) Drive unit
- 8) D-shackle threaded adapter (optional)
- 9) Snap shackle threaded adapter
- 10) 2:1 soft attach threaded adapter

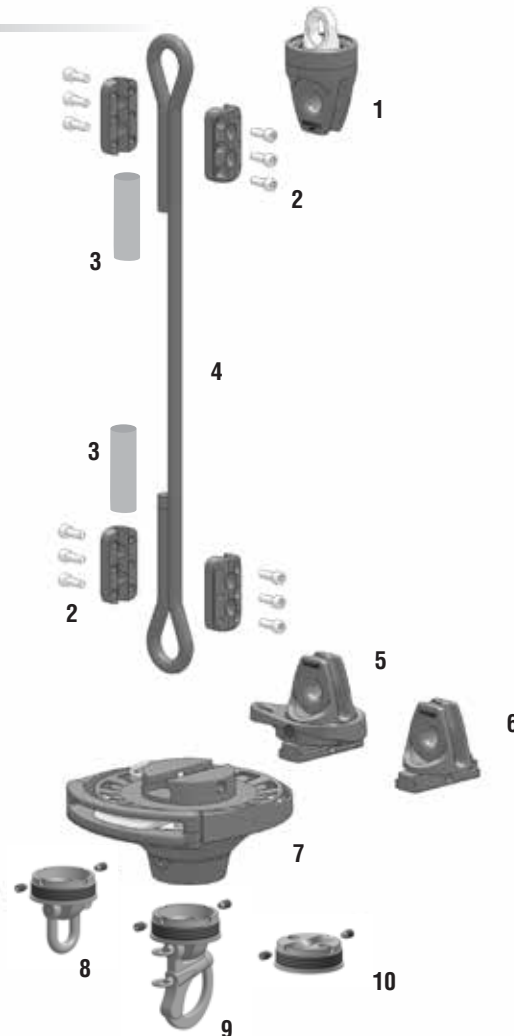

Terms

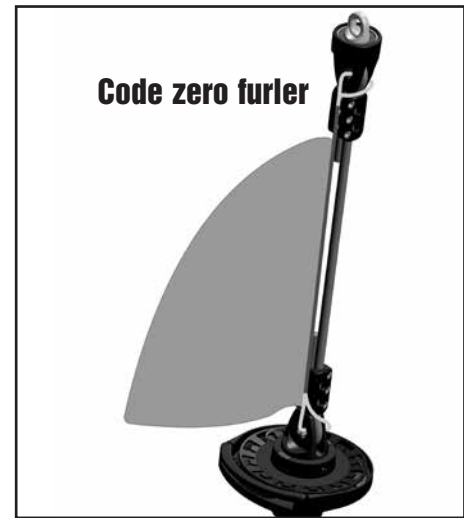
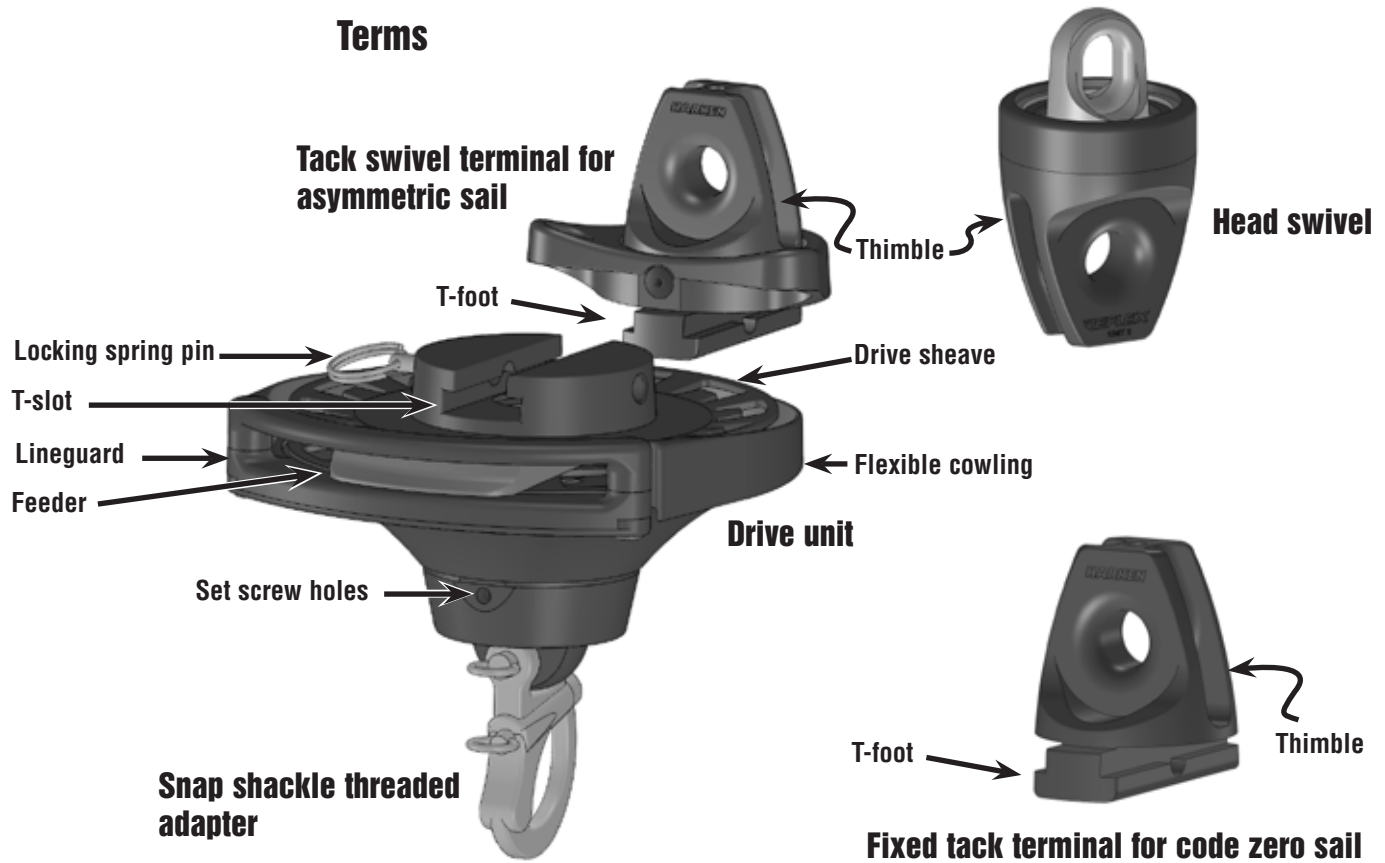

Size Check

Check recommended boat and sail size. **Note:** If you also plan to use the system for code zero sails, the loads will be higher so max boat and sail size will be smaller. If using for multihulls downsize maximums by 10%.

Unit size	Unit part no.	Intended application	Typical boat length		Maximum sail area	
			m	ft	m ²	ft ²
1	7351.10	Asymmetric spinnaker	7.5 - 11	25-36	112	1200
	7361.10	Code zero	6.7 - 10	22-32	60	650
2	7352.10	Asymmetric spinnaker	10 - 14	34 - 45	168	1800
	7362.10	Code zero	9 - 12	30 - 40	84	900

Main components



Head swivel with soft cover



Reflex torsion cable



Tack swivel terminal



Cable clamp set



Drive unit



Snap shackle threaded adapter

Optional components



Fixed tack terminal for code zero sail



D-shackle threaded adapter



D shackle only adapter



2:1/soft-attachment threaded adapter

Asymmetric furler - main components	Unit 1		Unit 2	
Head swivel with soft cover*	7351.28 (includes CV803 soft cover)		7352.28 (includes CV804 soft cover)	
Tack swivel terminal*	7351.26		7352.26	
Drive unit	7351.10BASE		7352.10BASE	
Reflex torsion cable (ordered by the foot)*	7371		7372	
Included in 7351.10 or 7352.10 systems	Unit	7371 cable length	Unit	7371 cable length
	7351.10.16M	16.15 m (53')	7352.10.20M	20.12 m (66')
	7351.10.18M	18.29 m (60')	7352.10.23M	22.87 m (75')
	7351.10.20M	20.12 m (66')	7352.10.25M	25 m (82')
Torsion cable clamp set*	7357		7358	
Snap shackle threaded adapter	7351.20		7352.20	
Optional components				
Fixed tack terminal (code zero sail)*	7351.27		7352.27	
Reflex torsion cable (by the foot) for extra sails*	7371		7372	
Reflex torsion cable spool (914 m - 3000')*	7371.SPOOL		7372.SPOOL	
D-shackle threaded adapter	7351.21		7352.21	
D shackle only - high resistance (HR)	2109 (6 mm HR)		2116 (8 mm HR)	
2:1/soft attachment threaded adapter	7351.22		7352.22	

*Order these components for extra sails. **Note:** Each extra sail has a head swivel, torsion cable, clamp, and track terminal

Main components



Head swivel with soft cover



Fixed tack terminal



Drive unit



2:1/soft-attachment threaded adapter

Optional components



Snap shackle threaded adapter



D-shackle threaded adapter



D shackle only

Code zero furler - main components	Unit 1	Unit 2
Head swivel with soft cover*	7351.28 (includes CV803 soft cover)	7352.28 (includes CV804 soft cover)
Fixed tack terminal*	7351.27	7352.27
Drive unit	7351.10BASE	7352.10BASE
2:1/soft attachment threaded adapter	7351.22	7352.22
Optional components		
Reflex torsion cable (by the foot)**	7371	7372
Torsion cable clamp set**	7357	7358
Snap shackle threaded adapter	7351.20	7352.20
D-shackle threaded adapter	7351.21	7352.21
D shackle only - high resistance (HR)	2109 (6 mm HR)	2116 (8 mm HR)

*Order these components for extra sails. **Note:** Each extra sail has a head swivel and fixed tack terminal. See note regarding Reflex cable.

** See diagrams below regarding use of Reflex torsion cable to improve furling.

Using the Reflex torsion cable with a code zero sail: The Reflex torsion cable is designed for furling an asymmetric spinnaker and transmits torque at lower halyard/luff loads than other types of torque cables. The Reflex torsion cable improves furling when used with a code zero type sail. **IMPORTANT! Always make sure there is a tension handling line as shown below.**

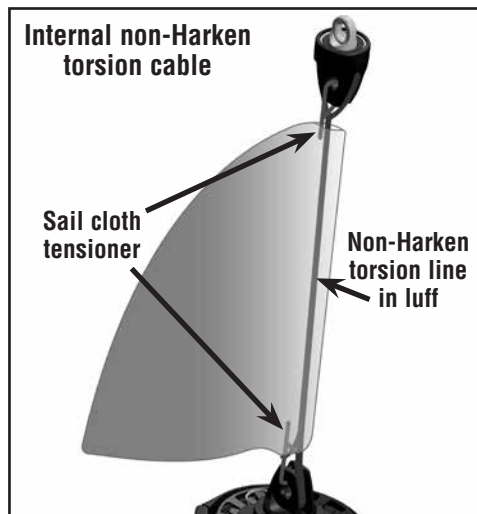
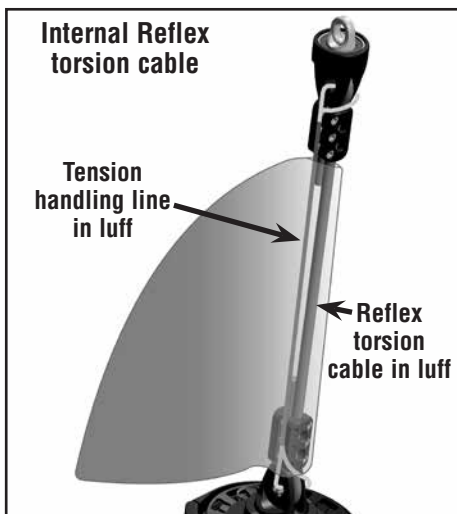
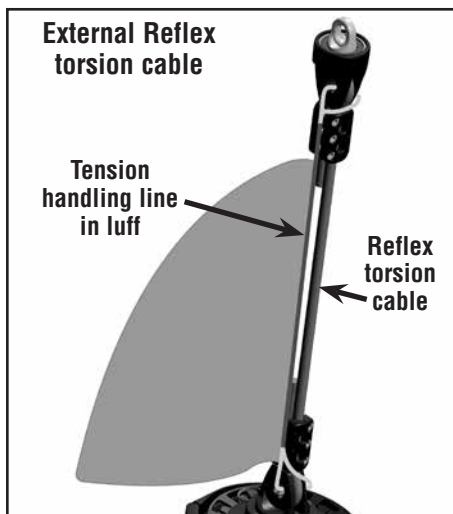

Continuous furling line - Talk to your rigging supplier about furling line construction using a structural cover over a nonstructural core. **Note:** Have the rigger capture the aft block in the loop before making the loop. The furling line loop can load into the stanchion leads and the drive unit after the line is spliced into a loop.

Determining furling line length - Refer to the chart below for line size and length. Double the loop length and add enough length for the overlap in the end-for-end splice.

Unit	Line diameter	Length of loop - cruise	Length of loop - race
1	6 mm (1/4")	Measure from furler to aft cockpit block	Use J dimension, plus bow sprit, minus 60 cm (2')
2	8 mm (5/16")		

Sail attachments: asymmetric spinnaker - Use a shorter soft shackle for head of sail and a longer soft shackle for the tack of sail. Consult a rigging supplier, a knot tying book or see a link to instructions at www.harken.com/knots.

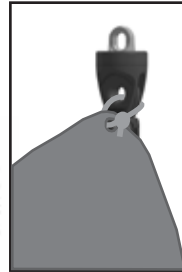

7356 fairlead kit - For cruising, lead the furling line loop back to the cockpit. Leads fit 25 mm (1") stanchions. Includes two double fairleads, a double fairlead with cleats, and aft block with bungee.

7355 double fairlead - Order if additional stanchion positions are required.

7360 Aft block with bungee - Order for race boat attachment near shrouds.



7356 kit



Aft block with bungee



7355 fairlead

Tools Required



- | | |
|-----------------------|------------|
| 1. Long tape measure | 4. Hacksaw |
| 2. Short tape measure | 5 Heat gun |
| 3. Metric hex keys | |

Luff length - asymmetric spinnaker

Note offset H at the top and offset D at the bottom. When using system for asymmetric spinnakers, D represents the attachment point to the tack swivel terminal.

Luff length - code zero

Note offset H at the top and offset E at the bottom representing the attachment points for the sail cloth.

Code zero luff cable

The Reflex torsion cable is designed for use with asymmetric sails and transmits torque at lower halyard/luff loads. When using the Reflex torsion cable with a code zero sail, make sure there is an additional tension-handling line used. Alternatively, use a tension-handling line that is torsionally resistant, and splice it to the thimble in the head swivel and the fixed tack terminal. This alternate method, using a non-Harken torsion line will require more tension to furl, making furling more difficult.

IMPORTANT! When using a 2:1 tack line, remember that it is pulling against the halyard. Downsize the diameter of the 2:1 tack line so that it does not overpower the stretch of the halyard.

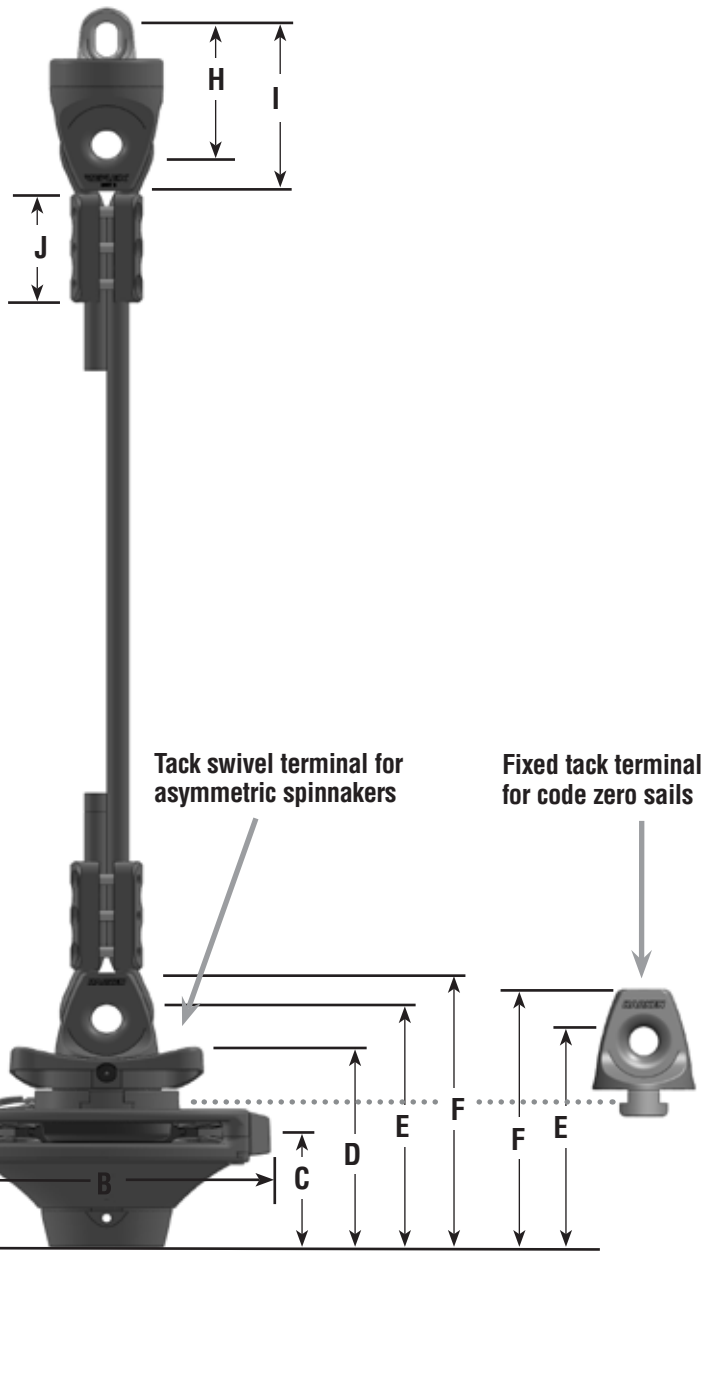

	Snap shackle A	D-shackle A	Diameter B	Line height C	Tack swivel D	Hole top E	Thimble top F	Hole bottom H	Thimble bot. I	Clamp ht. J	
UNIT 1	7351.10 Reflex furling system - Asymmetric spinnakers										
	55 mm	28 mm	140 mm	54 mm	94 mm	114 mm	131 mm	53 mm	83 mm	50 mm	
	2.16"	1.12"	5.5"	2.13"	3.7"	4.5"	5.17"	2.08"	3.27"	1.97"	
	7361.10 Reflex furling system - Code zero sails										
UNIT 2	7352.10 Reflex furling system - Asymmetric spinnakers										
	61 mm	38 mm	167 mm	64	111 mm	134 mm	152 mm	76 mm	93 mm	60 mm	
	2.41"	1.49"	6.59"	2.52"	4.35"	5.28"	5.97"	2.98"	3.67"	2.36"	
	7362.10 Reflex furling system - Code zero sails										
UNIT 2	61 mm	38 mm	167 mm	64	121 mm	138 mm	152 mm	76 mm	93 mm	60 mm	
	2.41"	1.49"	6.59"	2.52"	4.76"	5.47"	5.97"	2.98"	3.67"	2.36"	

REFLEX CABLE LENGTH WORKSHEET

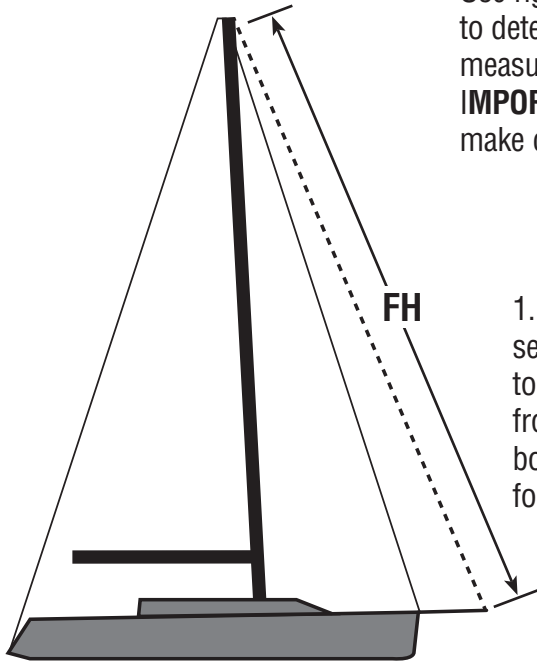

Use rig dimensions and worksheet below to determine cable length. Determine final measurements when building the terminals.
IMPORTANT! Use mast forward position. Do not make cable too long or it cannot tension.

1. Use long tape measure secured to shackle and hoisted to masthead. Measure FH length from full-hoist shackle to extended bowsprit fitting with mast in forward setting.

2. Determine A dimension depending on unit size and fill in the chart below.
Note: If using a 2:1 soft attach, measure or estimate the lowest A dimension.

A - Bottom of unit to bearing point of threaded adapter						
Threaded adapter	Unit 1 part no. and A distance			Unit 2 part no. and A distance		
2:1 soft attachment	7351.20			7352.20		
D-shackle	7351.20	28 mm	1.12"	7352.21	38 mm	1.49"
Snap shackle	7351.20	55 mm	2.16"	7352.22	61 mm	2.41"

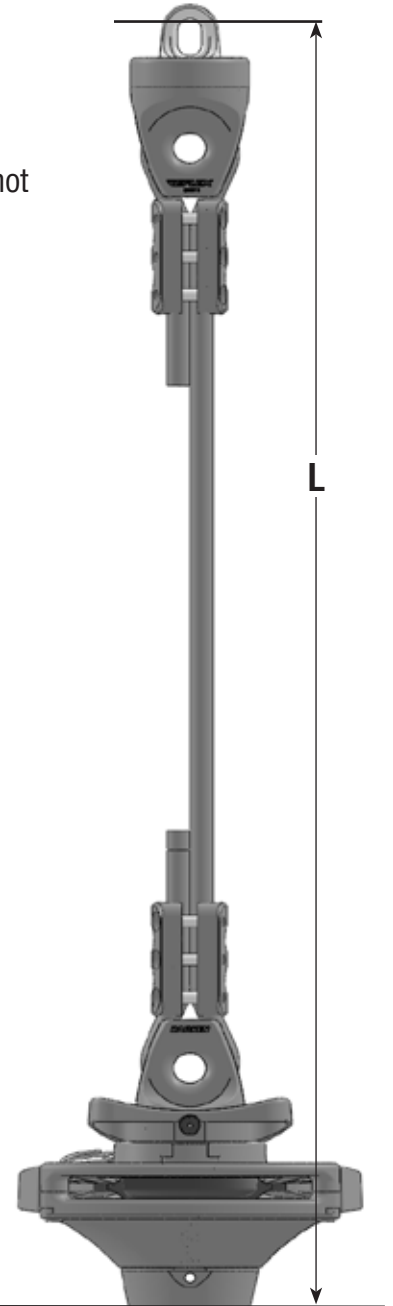
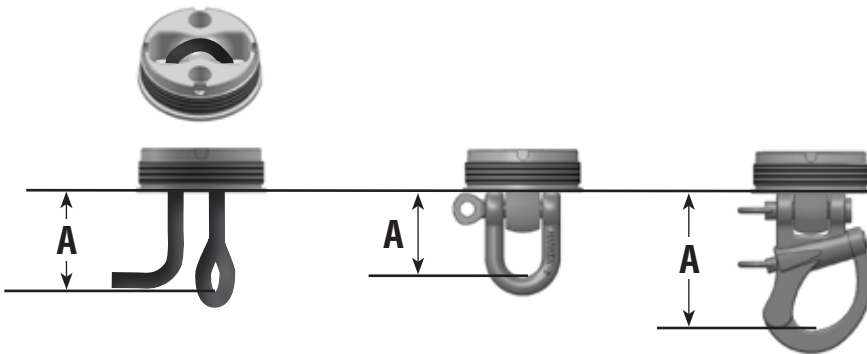

3. Use the worksheet below to determine the cable length (CL). **Note** the cable length (CL) is equal to the length (L). Make final length adjustments during assembly. The lengths below accommodate cable stretch when the halyard is tensioned.

Cable length worksheet				
Description	Unit 1		Unit 2	
	mm	in	mm	in
FH Full hoist shackle to bow forward attachment				
A Threaded adapter length to bottom of unit Subtract				
L Length (FH minus A) Length (L) is also the cable length CL				

Thread the adapter completely into the drive unit until it stops.



Back the adapter out no more than one (1) rotation until the set screw holes line up with the recesses at the top of the threaded adapter. Sight into one of the set screw holes to confirm alignment.

IMPORTANT! Make sure the adapter is either parallel or perpendicular to the feeder opening.

The parallel or perpendicular position will depend on the fitting on the bow sprit or extended bow fitting.

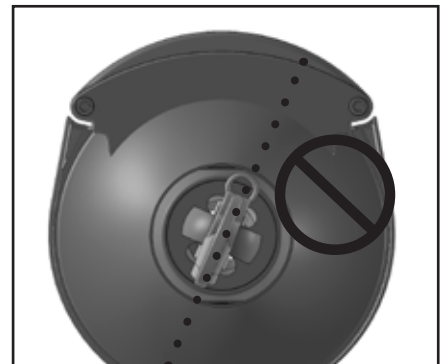
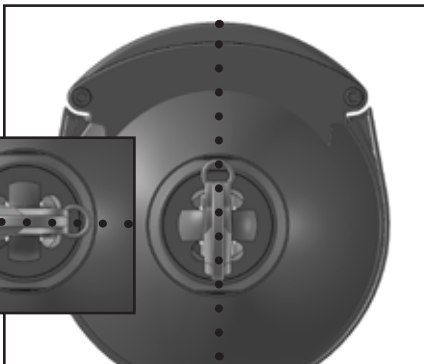

Install set screws using threadlocking solution such as blue Loctite® adhesive.

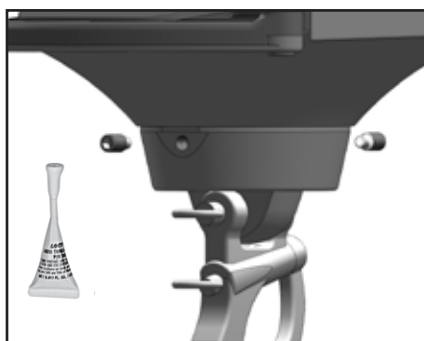

2:1 soft attach threaded adapter installs the same way as above. **Tip: Load the loop or 2:1 adjuster in the adapter before installing.**

Tip: The D-shackle adapter and snap shackle adapters use the same threaded bases so you can switch the shackles to change types.



IMPORTANT! - Wait to cut the torsion cable to length until you have clamped the cable to the head swivel. Plan on a length check with drive unit as you build the tack terminal.

1. Locate the clamp halves and the long fasteners (M5 X 25 mm) as shown. Cut the supplied heat-shrink tubing in half.

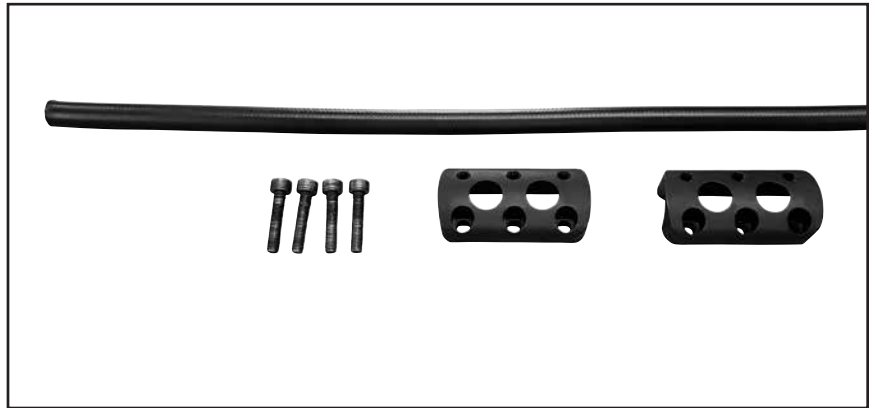

2. Slide the heat-shrink tubing onto the cable. Assemble the clamp halves near the cable end using four (4) longer screws threaded into the corner holes. Turn several turns as shown and leave enough space to load the cable end.

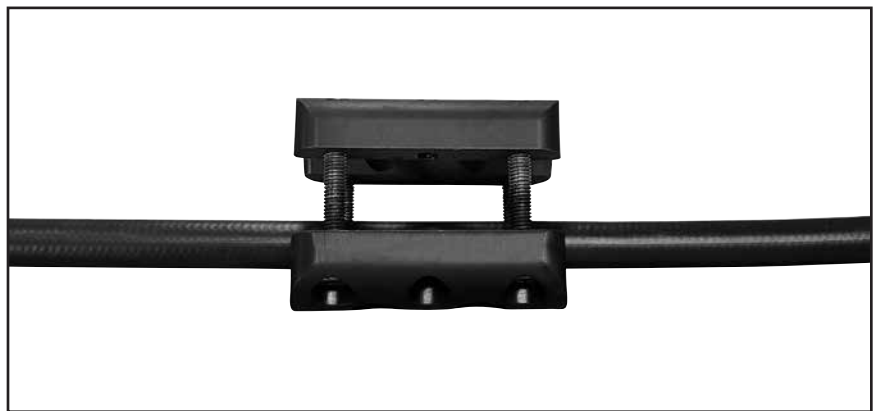

3. Insert the end of the cable through thimble at the head swivel and position it at the desired location on the cable. Slide the clamp assembly over the end of the cable as shown. **Tip: Secure the head swivel in a vise when building the terminal to hold it in place.**

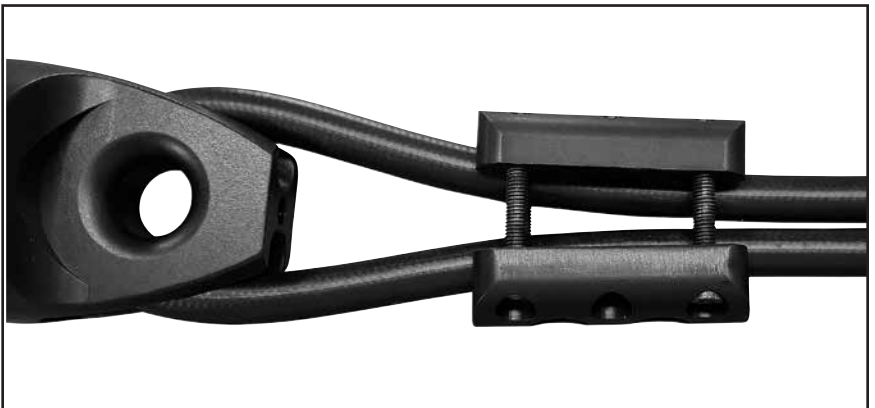

4. Push the clamp assembly toward the thimble. Squeeze the torsion cable at the thimble. Position clamp about 10 mm (3/8") from the thimble as shown. Make the tail of the cable about 90 mm (3.5") beyond the clamp.

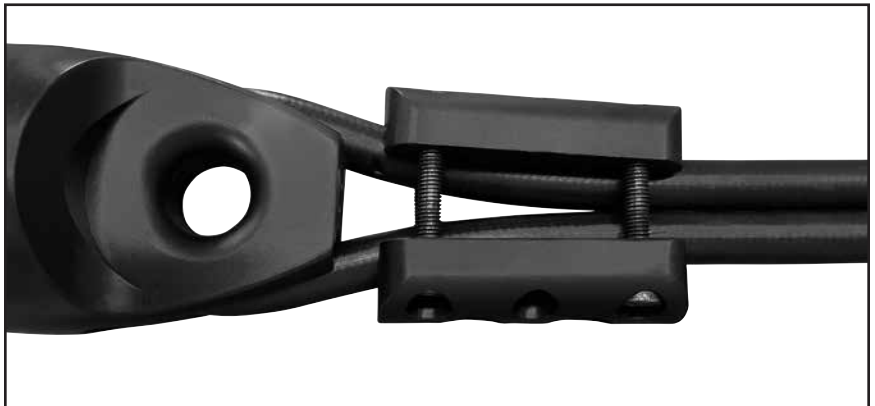

IMPORTANT! - Wait to cut the torsion cable to length until you have clamped the cable to the head swivel. Plan on a length check with drive unit as you build the tack terminal.

5. Gradually tighten each of the four (4) corner fasteners, alternating to maintain a relatively even gap between clamp halves. When the gap is about 8 mm (5/16"), locate two (2) of the short fasteners supplied (M5 X 16 mm). Apply blue Loctite and thread the fasteners into the two remaining screw locations. It is not necessary to tighten these at this time.

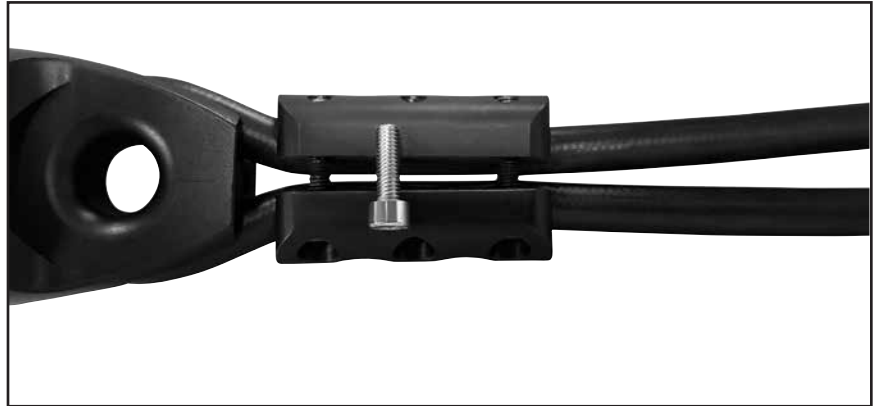

6. Continue to tighten the four (4) corner fasteners until the gap between the clamp halves is around 5 mm (3/16"). Now tighten the two center fasteners until snug.

7. Remove each of the long corner fasteners and replace with a short fastener using blue Loctite.

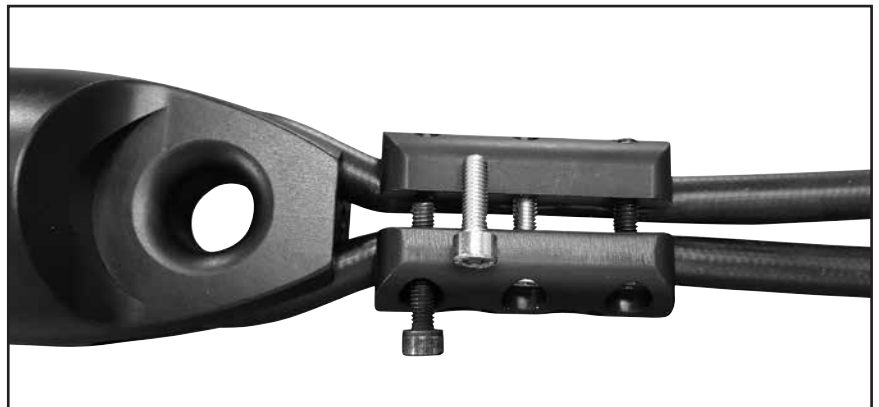

8. Gradually tighten all fasteners, alternating to maintain a relatively even gap between the clamp halves. Assembly is complete when all fasteners achieve a maximum torque of 5.6 Nm 50 in-lb (5.6 Nm). The gap between the clamp halves should be even and nearly closed.

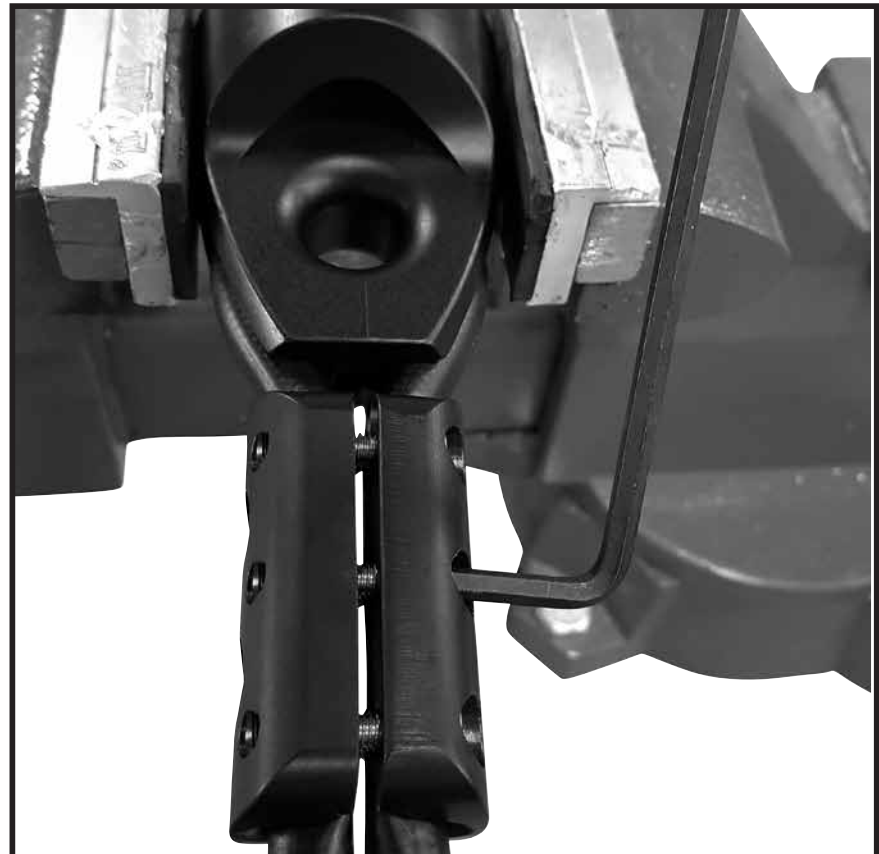

9. Slip shrink tubing over end and use heat gun to cover end and main cable.

IMPORTANT! Be careful not to damage cover of Reflex cable.

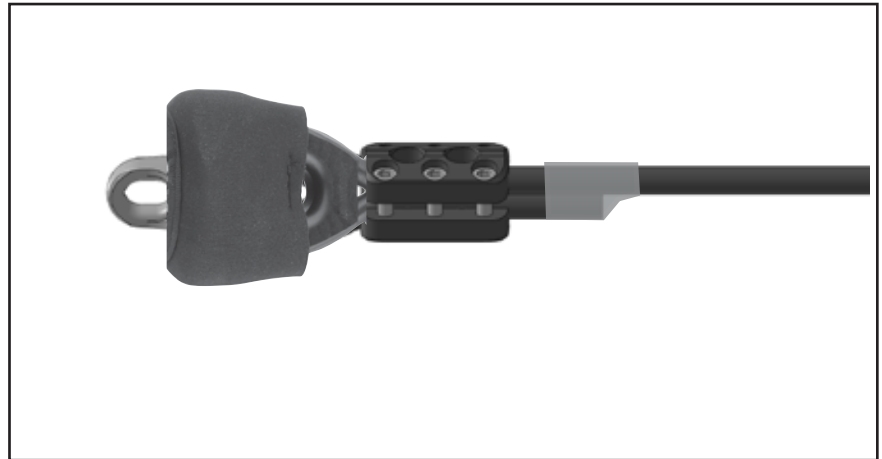

10. If assembling away from the boat, lay cable out straight. Install tack terminal on drive unit. **Note:** See following pages for alternate method of determining length at boat.

IMPORTANT! Slide the heat-shrink tubing onto the cable before slipping the cable into the thimble. Slip the cable into the thimble and check to make sure the unit is shorter than the (FH) full-hoist length by the amount shown in the chart. Clamp cable and use hacksaw to cut the cable leaving a tail of:

Unit 1 - 90 mm (3.5")

Unit 2 - 100 mm (4")

Tip: Leave a longer tail if you are not sure about measurements. See following pages on determining length at boat.

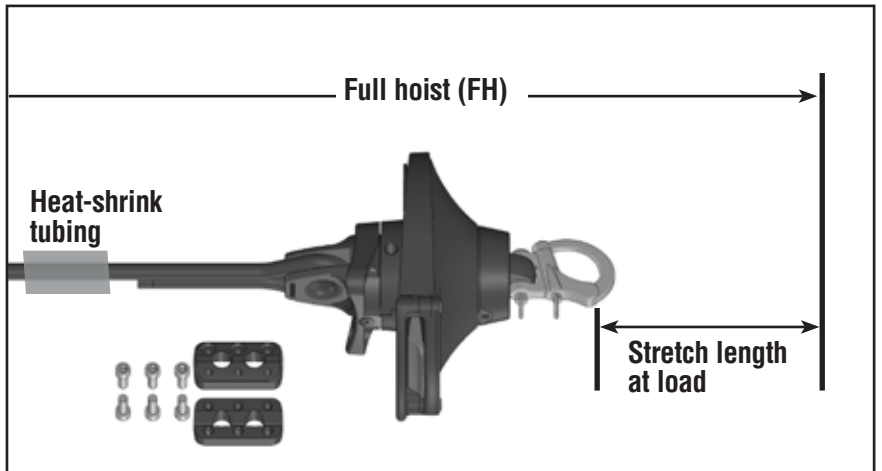

Estimated stretch length at load				
Full hoist (FH) length	Unit 1		Unit 2	
	14 to 16 m (45 to 53')	200 mm	8"	-
16 to 18 m (53 to 59')	240 mm	9 1/2"	300 mm	12"
18 to 20 m (59 to 66')	280 mm	11"	350 mm	14"
20 to 23 m (66 to 75')	320 mm	13"	400 mm	16"
23 to 25 m (75 to 82')	-	-	450 mm	18"

11. Follow the procedure used to build the head swivel terminal.

Note: Wait to shrink the heat-shrink tubing until the sail is hoisted and sailed in case length adjustments are necessary. See length check at end of assembly section, step 8.

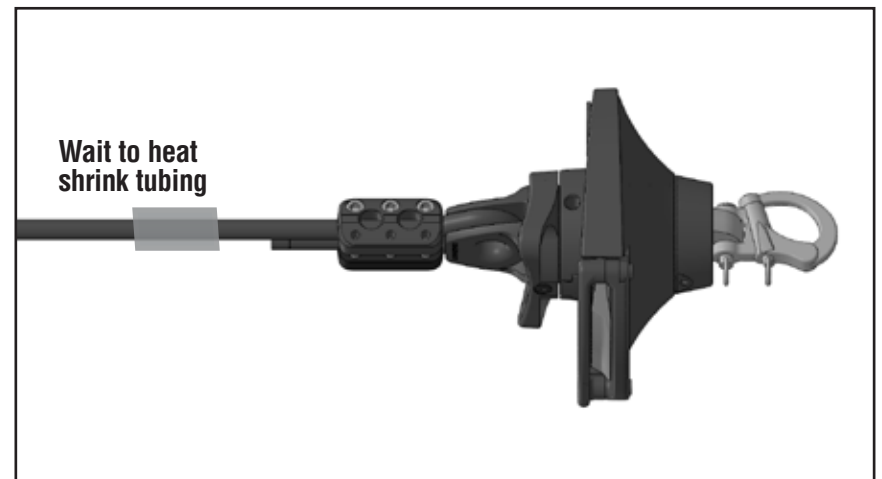

Physical length determination at the boat - Use instead of measuring and referring to charts.

Moor the boat so you can reach the end of the sprit from the dock. Have the mast in forward setting for running; use a halyard to pull the mast forward.

1. Dry-fit setup at boat: Hoist the head swivel with cable installed to the top of the mast. Bottom end of cable will be open, no lower unit.

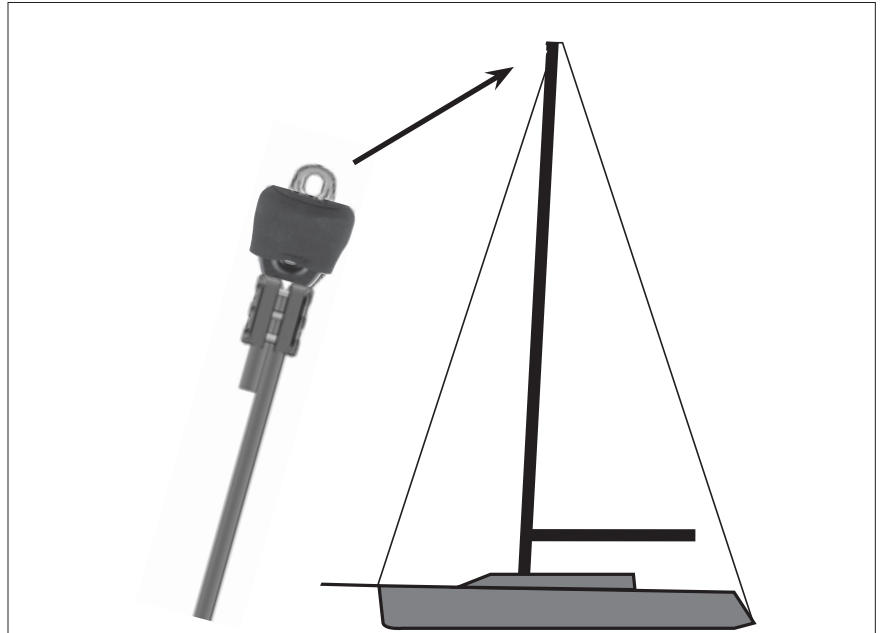

Install the tack swivel terminal on the drive unit by pulling the locking spring pin and slipping the T-foot of the terminal into the T-slot in the drive unit.



2. Finding cut length: Attach the lower unit assembly to the tack line or fixed bail and pull the tack line all the way down. Slip the bottom of the cable through the thimble in the tack terminal. Pull the cable as tight as you can by hand, and wrap a piece of electrical tape **where the cable enters the thimble** as a mark.

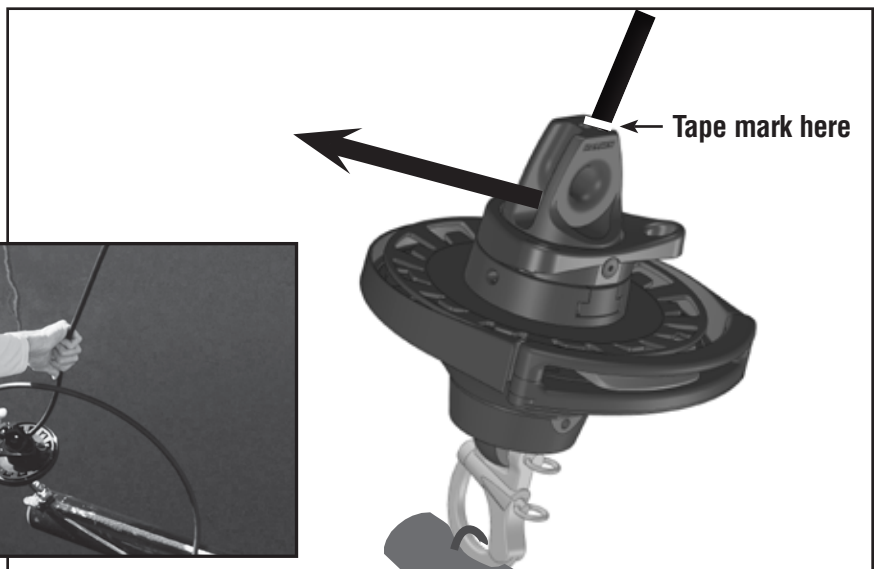
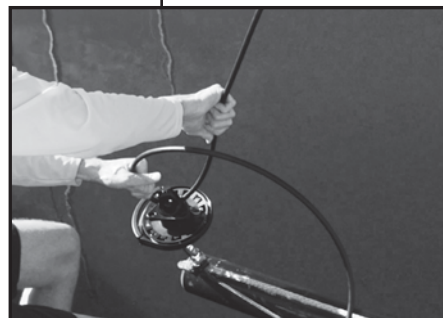

3. Cutting the cable: Lower the cable to the dock. Clamp the cable to the dock and cut the cable using a hacksaw.

Note: Cutting the cable at the mark may seem too short; however, when the halyard tensions, the cable will stretch from 200 to 400 mm (8 -16"), depending on the unit size and the cable length.

Tip: *If you prefer, cut the cable so it is a few inches longer and use a Dremel-type small circular saw to cut it after assembly and applying halyard loads.*



4. Finding stretch length: Refer to the chart at right and use tape to mark the cable the distance shown. The mark will be located at the point where the cable enters the thimble. It represents the amount of stretch when the torsion line is tensioned when hoisted.

Amount to pull through thimble - Estimated stretch length at load				
Full hoist (FH) length	Unit 1		Unit 2	
	14 to 16 m (45 to 53')	200 mm	8"	-
16 to 18 m (53 to 59')	240 mm	9 1/2"	300 mm	12"
18 to 20 m (59 to 66')	280 mm	11"	350 mm	14"
20 to 23 m (66 to 75')	320 mm	13"	400 mm	16"
23 to 25 m (75 to 82')	-	-	450 mm	18"

IMPORTANT! Slide the shrink wrap onto the cable before slipping cable into thimble.

5. Setting the length - Slip the cable into the thimble and pull it through until the mark from step 4 is at the point where the cable enters the thimble.

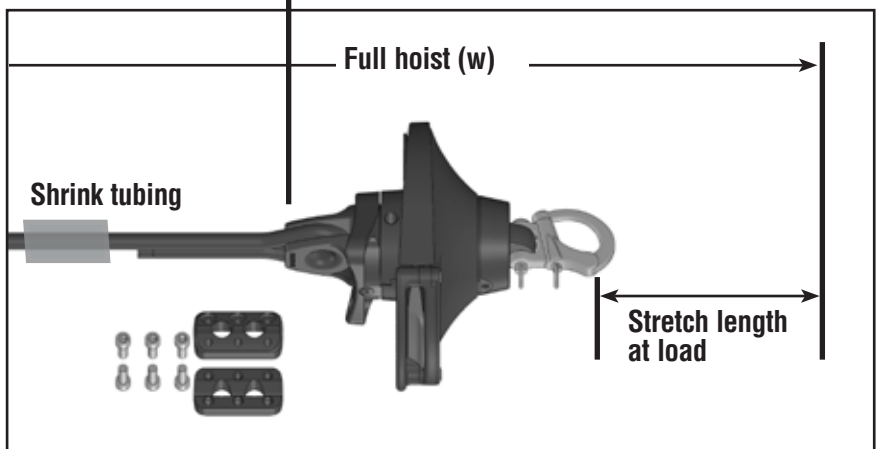
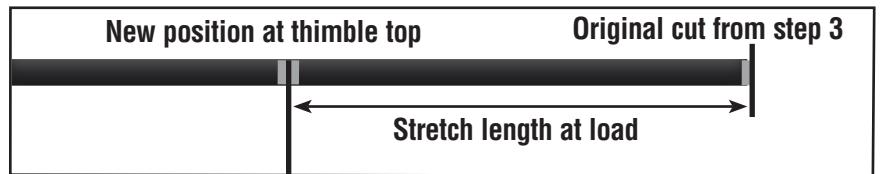

6. Building the tack terminal: Follow the procedure used to build the head swivel terminal.

Tip: *Wait to shrink the heat shrink tubing until the sail is hoisted and sailed in case length adjustments are necessary.*

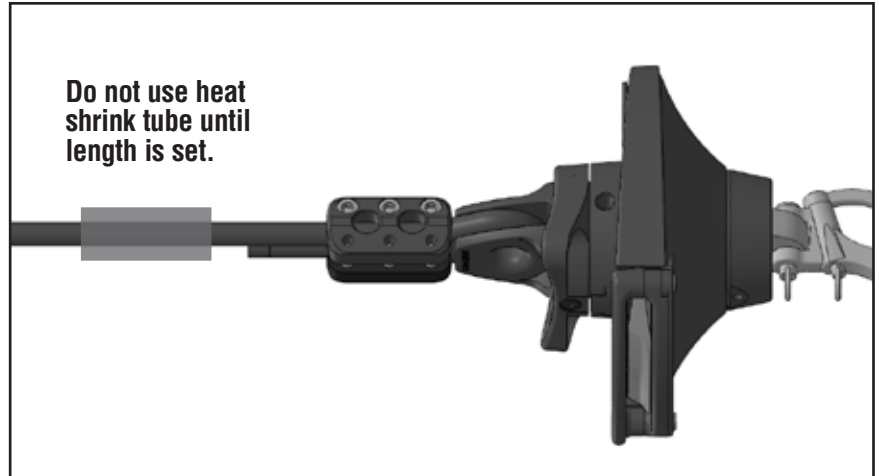

8. Checking the length: Attach the drive unit to the bow fitting or pole. Hoist the cable without sail to check the length. Use the halyard winch to tension the halyard enough to straighten the cable.

Tip: *Unlike fibrous torsion cables, the Reflex torsion cable transmits torque at lower halyard loads. IMPORTANT! Over-tensioning the halyard can make furling more difficult and can damage components.*

Adjust the tack line if necessary.

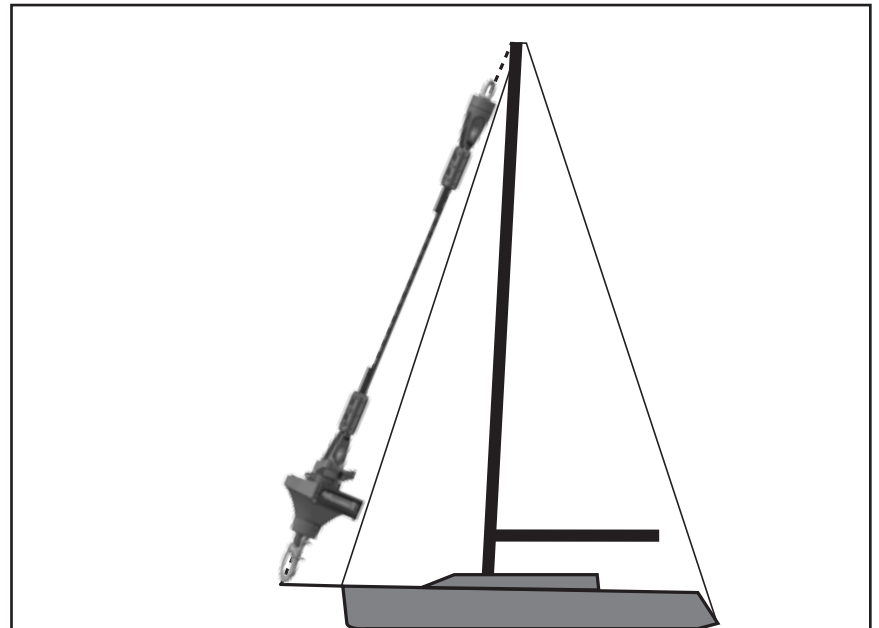

Make sure the torsion cable is not attached to the drive unit. Load the looped furling line into the line guard.



Work the line into the space between the drive sheave and the flexible cowling.



Rotate the drive sheave as you press the line into position around the drive sheave. Load the final part by pulling the line from outside the drive unit.



Commissioning

Mounting fairleads to stanchions: Furling line can be led down either side of boat. The leads are designed for running furling line outboard of the stanchions. **Note:** Do not run the line on the inboard side of stanchion.

Plan the lead system referring to the diagram below. The lead with cleats should be easily accessible. The aft block with bungee keeps some tension on the furling line.

Remove four (4) screws on stanchion leads.

Note: Clamp leads to stanchion so the black plastic clamp side is inboard and the metal line guide is outboard.

Tip: Start all four (4) screws before tightening.

Load the furling line loop into the fairleads by rotating the line to line up with the openings. Push the line into place.

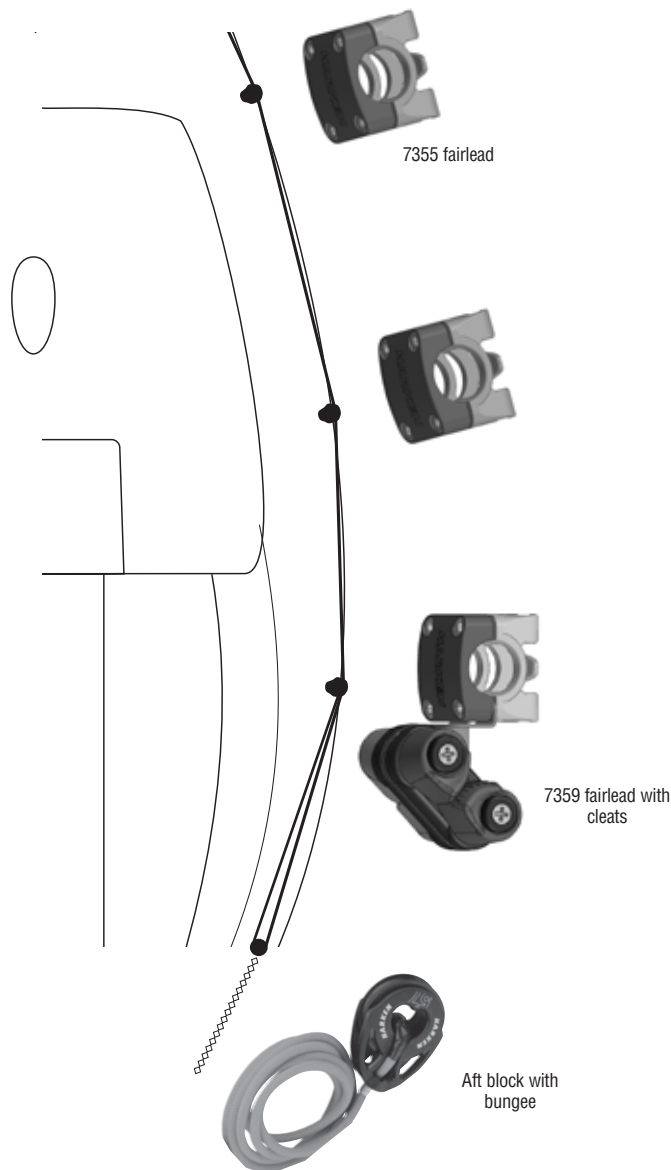

Mounting Fairleads - Line to Cockpit

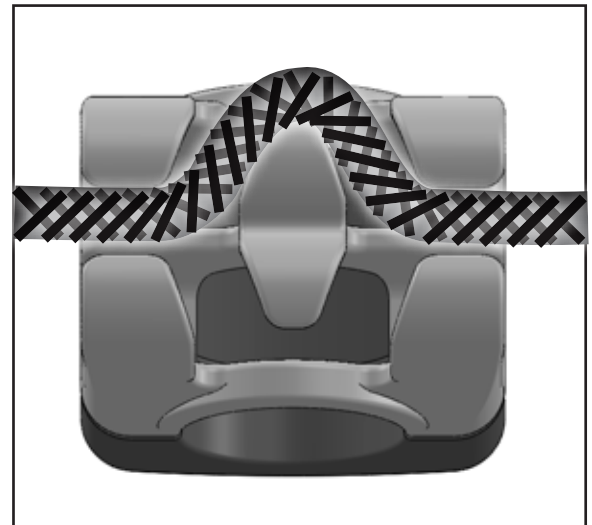
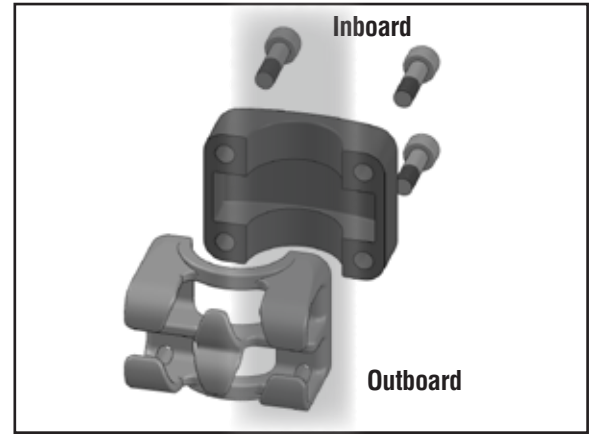

Aft block is used at the end of the system.

For racing: Mount the aft block with bungee near the shrouds. By using a clip at the end of the bungee cord you can easily clip it to port side or starboard. For distance racing, furling can always be on the weather side.

Pre-hoist checklist

There are several assembly steps described in detail in the installation manual.

- Lower drive unit attached to bow with line guard facing aft
- Looped furling line installed on drive unit and led aft
- Head swivel and tack swivel clamped to torsion cable and length checked
- Soft-attach shackle available for attaching head of sail to head swivel
- Soft-attach lashing or shackle available and sized for attaching tack to swivel tack terminal

Preparation for first sail hoist: Sail is in bag, unfurled.

Tip: Pick light breeze conditions. Have no jib or have jib furled. Subsequent hoists will be much easier because sail will be furled.

Tip: Temporarily secure the furled jib sheets downward toward the deck to help keep the Reflex furling system, spinnaker sheets, and halyard outside of the jib sheets.

Asymmetric spinnaker: Attach the head of the sail to the eye in the head swivel using a soft shackle or lashing.

Note: Head swivel has a soft cover to protect mast.

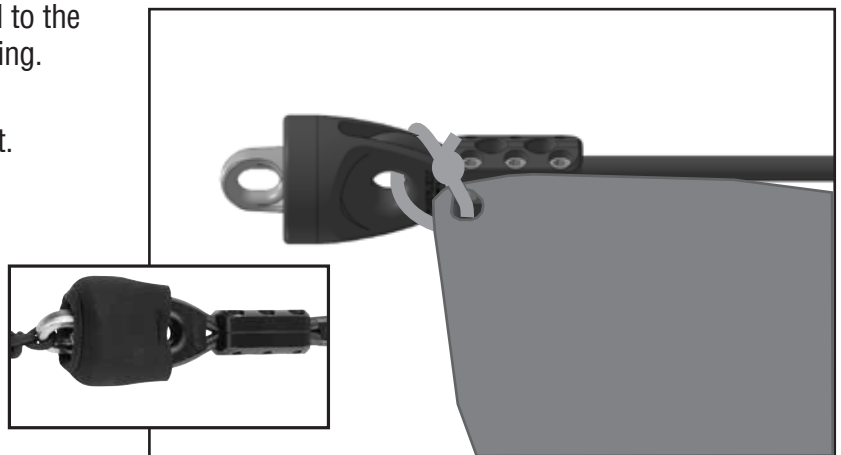

Asymmetric spinnaker: Secure tack of sail using soft-attach long shackle. Make length adjustable for adjustment when sail is finally fitted.

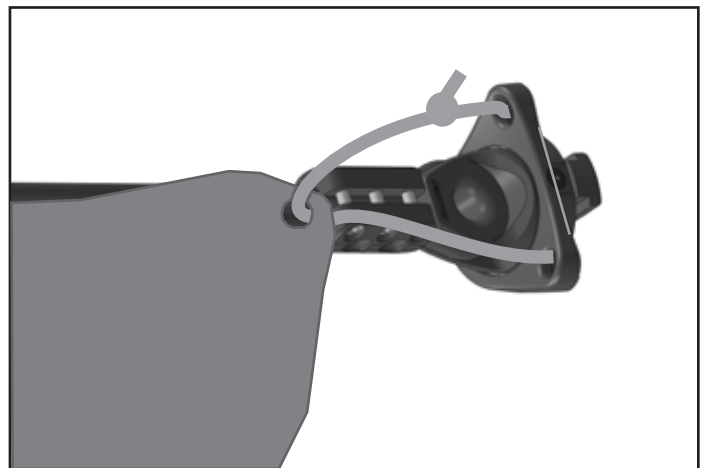

Load the Reflex tack terminal into the T-slot on the lower drive unit. Attach the unit to the bow sprit or a fixed point on the bow ahead of the stay. Attach halyard to head swivel and check halyard and sheet leads. Hoist and trim spinnaker.

Halyard Tension: Tension the halyard to pull slack out of the Reflex torsion cable. Adjust the tack line if necessary. Use the winch to pull the halyard until the rolled sail is straight. **IMPORTANT! Over-tensioning the halyard can make furling more difficult as you load components. Unlike fibrous torsion cables, the Reflex torsion cable transmits torque at lower halyard loads. Too much tension can damage components.**

IMPORTANT! If using a code zero sail, always use a tension handling line. See code zero page to follow.

Furling

Prepare both spinnaker sheets so they are ready to run. Pull the continuous furling line and the lower drive unit rotates the Reflex torsion cable which immediately rotates the head swivel, furling the sail around the torsion cable beginning at the top.

Tip: When furling, control the amount the sail flogs. From a broad reach, ease the sheets to reduce sail power. Start furling and then ease more.



When furling an asymmetric spinnaker, the sail tack is on a swivel and does not begin furling until most of the sail is furled. When furling a code zero sail, the sail tack is fixed.

Continue furling by easing the sheet part way and furling so flogging is minimized and there is some drag on the sheets. Furl until the clew pennant or sheets are securely wrapped around the furled sail.



The furling action when furling an asymmetric spinnaker and track swivel terminal is top-to-bottom; furling starts at the sail head and moves downward.



Furling

Prepare both spinnaker sheets so they are ready to run. Pull the continuous furling line. The lower drive unit rotates the head and tack of sail. The furling action is along the luff.

IMPORTANT! When using the Reflex torsion cable with a code zero type sail, always use a tension handling line as shown below. To furl a code zero sail that has a preexisting non-Harken torsion cable sewn into the luff, use either the thimbles or the eyes to secure to the head swivel and fixed tack terminal.

Tip: When furling, control the amount the sail flogs. From a broad reach, ease the sheets to reduce sail power. Start furling and then ease more.



Continue furling by easing the sheet part way and furling so flogging is minimized and there is some drag on the sheets. Furl until the clew pennant or sheets are securely wrapped around the furled sail.



Lower furled sail and stow.



Lowering: Lower the rolled sail and remove the entire unit from the retracted sprit, or use the T-slot and leave the lower drive unit with furling line and sheets on the bow. Coil the furled sail in a large bag. Tip: A large rectangular bag (3:1 ratio) stows nicely. If removing the lower drive unit, gather the furling line and sheets into the bag.



Hoisting furled sail:

After the initial hoist and furl, the Reflex system will be ready for hoisting while furled. These items were covered previously in the first sail-hoist section.

Checklist:

- Head of sail securely attached to head swivel
- Tack secured to tack swivel terminal
- Tack swivel terminal loaded into T-slot in lower drive unit
- Unit secured to bowsprit or bow fitting
- Furling line led aft below jib sheets to aft lead block
- Spinnaker sheets attached, and led around forestay and aft to spinnaker blocks outside and above all other sheets
- Halyard attached

Hoisting steps:

- Pull tack out to pole if adjustable
- Pull bowsprit out
- Hoist furled sail from the weather side to avoid having to go under the foot of the jib. The head swivel stays ahead of the rig. Work the furled sail outboard and forward while hoisting furled sail.

Unfurling sail:

Make sure sheets are led correctly and leeward sheet is ready to trim. Make sure that the furling line is clear to run and people are clear of the line.

As you are unfurling, head up a little so wind begins to unfurl the sail. As it is filling, bear off to reduce the wind in the sail. Let the sail unfurl and spin the furling line.



WARNING! Stand clear of the drive sheave and the furling line when sail is unfurling. Trying to grab the line and slow it can result in injury. Keep fingers clear of the spinning drive sheave.



Reflex furler

Sail Changes: Changing furled sails is easy. Components are available for each sail.

Asymmetric spinnakers - Order these additional parts.

- Head swivel
- Tack swivel terminal
- Reflex torsion cable
- Torsion cable clamp set

Code zero sails - Order these additional parts.

- Head swivel
- Fixed tack terminal
- Reflex torsion cable
- Torsion cable clamp set

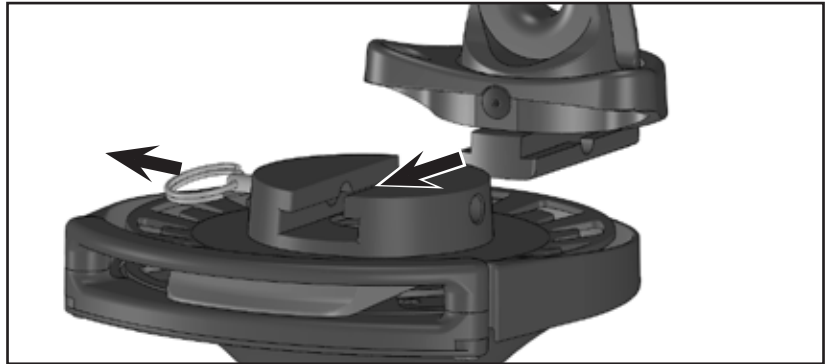

The sail may have an existing torsion line in the luff. Talk to your sailmaker about installing a Harken Reflex torsion cable. Requires a separate Dyneema® type tension-handling luff line.

Changing Sails: With the new sail furled and ready to go, changing sails is quick and easy. Simply pull the spring pin, slide out one (1) assembly and slide the new sail assembly into the lower drive unit. You can even switch from a free-flying sail to a code zero sail. Note the fixed tack terminal. Switch sheets and hoist as normal.

Dyneema is a registered trademark of DSM IP Assets B.V.L.L.C

General cleaning procedure: Keep your equipment clean and free running by frequently flushing with fresh water. Periodically clean with mild detergent and water solution. Spin components to distribute soap solution evenly. Flush with fresh water. Use this process for flushing procedures below.

Head swivel: Flush exterior of swivel, inside the thimble, and the clamp mechanism. Inspect all components for signs of chafing, wear, or damage and replace if necessary.

Reflex tack swivel terminal: Flush bearings with soapy water and rinse as you rotate tack swivel.

T-slot mechanism: Periodically remove the Reflex swivel tack terminal from the T-slot and flush parts. Be sure to operate and flush the spring pin.

Lower drive unit: Remove furling line and flush lower unit on either side of the feeder. Rotate the drive sheave to flush bearings. *Tip: The drive unit easily removes from the sail for thorough flushing. Turn unit upside down and flush interior.*

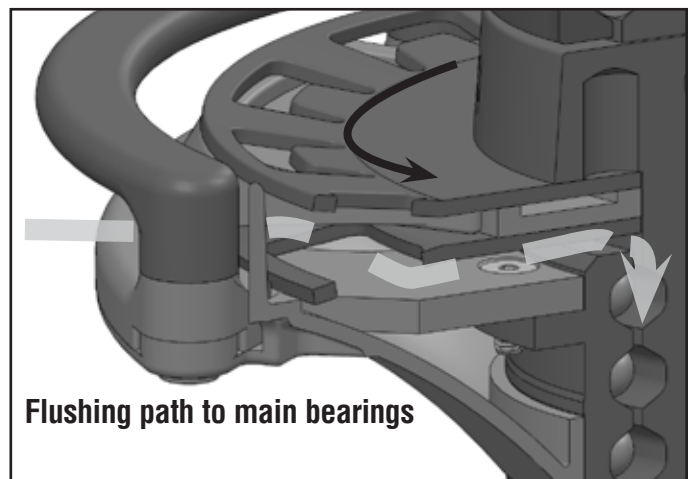

Inspection: Carefully examine all fasteners and tighten as necessary. Inspect all shackles and soft attachments for signs of chafing, splices failing, or wear. Replace as necessary.

Storage: Make sure all parts are rinsed and dry before long-term storage.

Warranty
www.harken.com/manuals
or call, write, email or fax Harken, Inc.,
Pewaukee, WI USA

HARKEN®

Corporate Headquarters

N15W24983 Bluemound Rd, Pewaukee, WI 53072 USA
Telephone: (262) 691-3320 • Fax: (262) 701-5780
Web: www.harken.com • Email: harken@harken.com

Harken Australia Pty, Ltd.

1B Green Street, Brookvale, N.S.W. 2100, Australia
Telephone: (61) 2-8978-8666 • Fax: (61) 2-8978-8667
Web: harken.com.au • Email: info@harken.com.au

Harken France

ZA Port des Minimes, BP 3064, 17032 La Rochelle Cedex 1, France
Telephone: (33) 05.46.44.51.20 • Fax: (33) 05.46.44.25.70
Web: harken.fr • Email: info@harken.fr

Harken Italy S.p.A.

Via Marco Biagi, 14, 22070 Limido Comasco (CO) Italy
Telephone: (39) 031.3523511 • Fax: (39) 031.3520031
Web: harken.it • Email: info@harken.it

Harken New Zealand, Ltd.

158 Beaumont Street
Unit 11, Orams Marine Centre
Westhaven, Auckland, 1010, New Zealand
Telephone: (64) 9-303-3744 • Fax: (64) 9-307-7987
Web: harken.co.nz • Email: harken@harken.co.nz

Harken Polska Sp. z o.o.

ul. Przasnyska 6A, 01-756, Warszawa, Poland
Tel: +48 22 561 93 93 • Fax: +48 22 839 22 75
Web: harken.pl • Email: polska@harken.pl

Harken Sweden AB

Main Office and Harken Brandstore: Västmannagatan 81B
SE-113 26 Stockholm Sweden
Telephone: (46) 0303 61875 • Fax: (46) 0303 61876
Mailing address: Harken Sweden AB, Box 64, SE -440 30 Marstrand
Web: harken.se • Email: harken@harken.se

Harken UK, Ltd.

Bearing House, Ampress Lane, Lymington, Hampshire SO41 8LW, England
Telephone: (44) 01590-689122 • Fax: (44) 01590-610274
Web: harken.co.uk • Email: enquiries@harken.co.uk

**Please visit: <http://www.harken.com/locator.aspx>
to locate Harken dealers and distributors**