

SMARTCODE 910

TOUCHPAD ELECTRONIC DEADBOLT

Programming and Troubleshooting Guide

1	Mastercode	2
2	Troubleshooting: Door Jamming and Door Handing	6
3	Troubleshooting: Keypad	11
4	Troubleshooting: Smart Home Systems	12
5	Troubleshooting: Battery	14
6	Battery FAQ	15

1 Mastercode

A About the Mastercode

Using a Mastercode is an optional, added-security measure. It is not enabled by default. A Mastercode is used to add and delete user codes, but it cannot unlock the door (unless the same code is programmed as a user code, though this is not recommended). The Mastercode must be 4-8 digits.

B Enabling and Setting the Mastercode

Programming timeout: If no button is pressed for five seconds, the system will time out and you will need to restart the procedure.

1. Keep door open. Press and HOLD the Program button until the keypad flashes green (about 5 seconds).

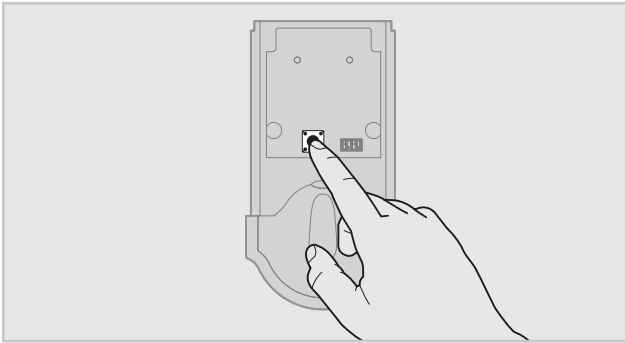

4. Re-enter Mastercode.

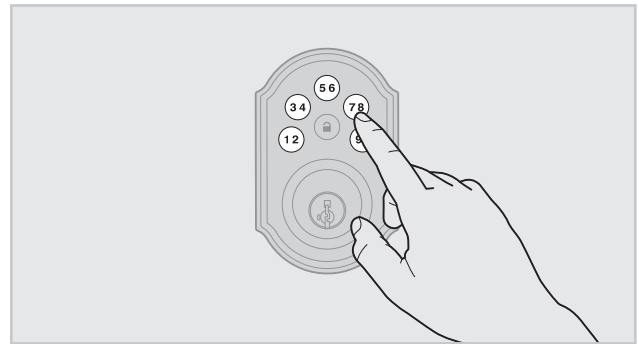

2. Enter new Mastercode.

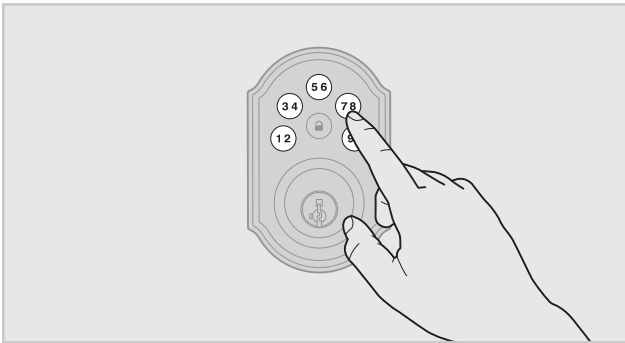

5. Press Lock button once.

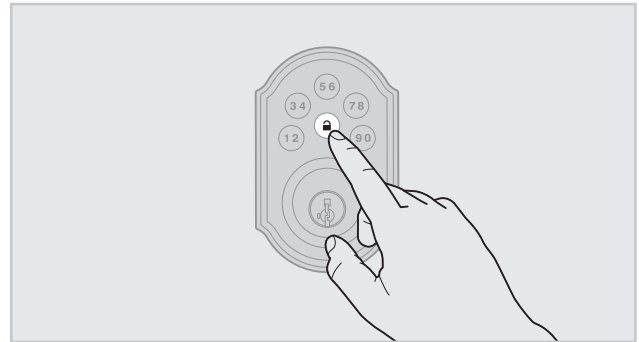

3. Press Lock button once.

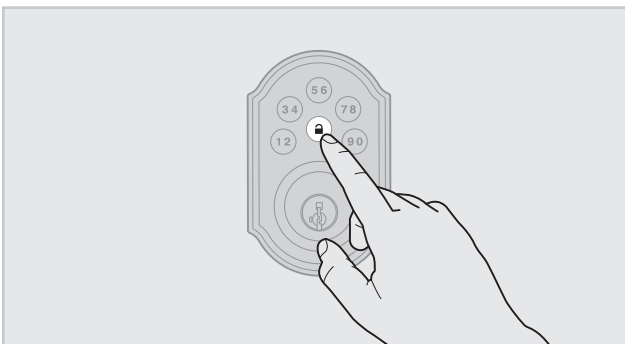

If programming is successful, the keypad will flash green once with one beep.

If programming is unsuccessful, the keypad will flash red three times with three beeps. Make sure the Mastercode has not already been programmed. Attempt the procedure again, making sure to enter the same new Mastercode in step 2 and 4.

6. Make sure switch #3 is on, and press the Program button once. If you hear three beeps and see the keypad flash green three times, the Mastercode is enabled.

Note: The lock will time out after five seconds.

C Adding User Codes with the Mastercode Enabled

The procedure for adding user codes is different when the Mastercode is enabled. For instructions on how to add user codes when the Mastercode is disabled, see the Installation and User Guide that came with your lock.

1. Keep door open. Press the Program button once. The keypad will flash green and you will hear three beeps.

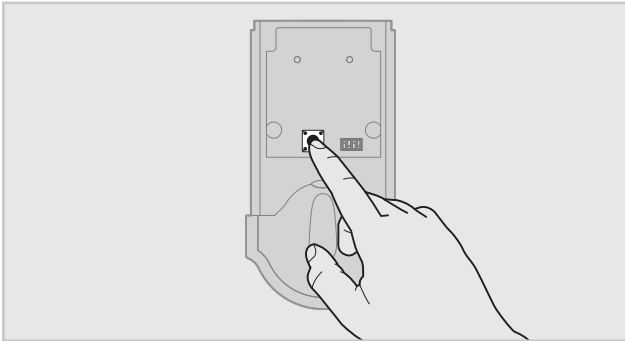

2. Enter Mastercode.

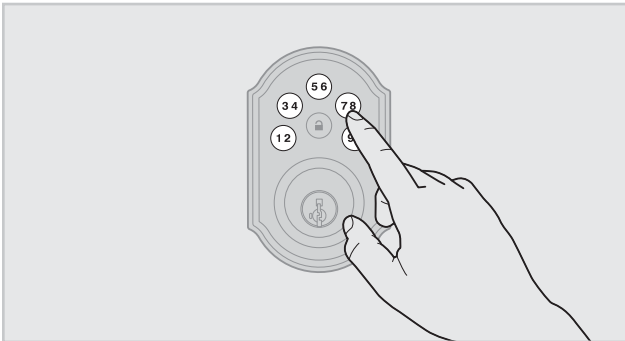

3. Press Lock button once.

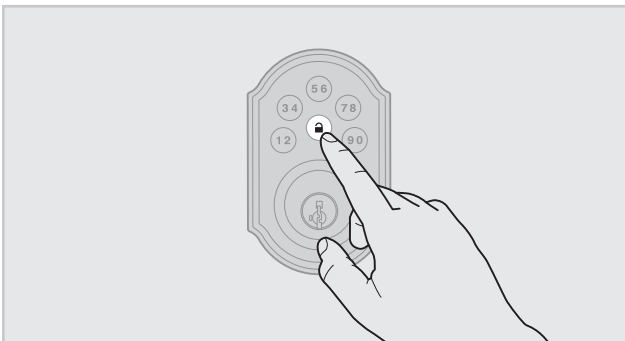

4. Press the Program button the number of times that corresponds to the user code position being programmed.
Example: If programming the third code, press the button three times.

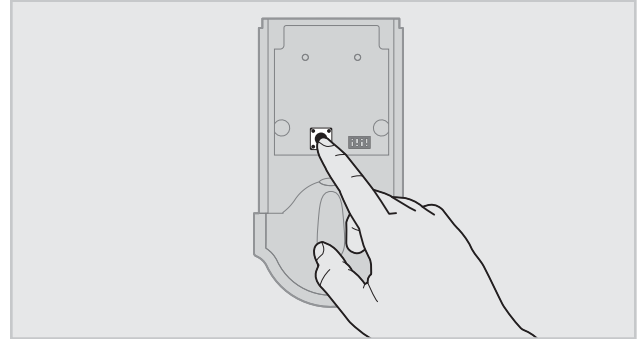

5. Enter new user code.

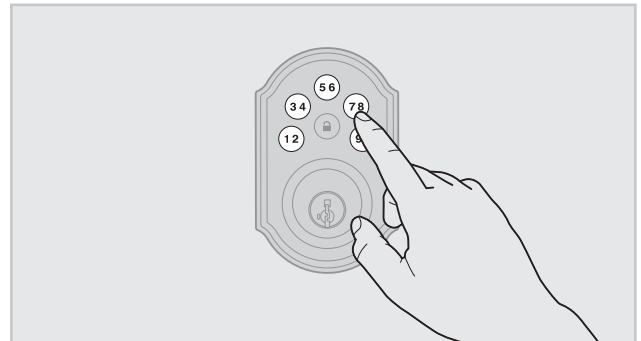

6. Press Lock button once.

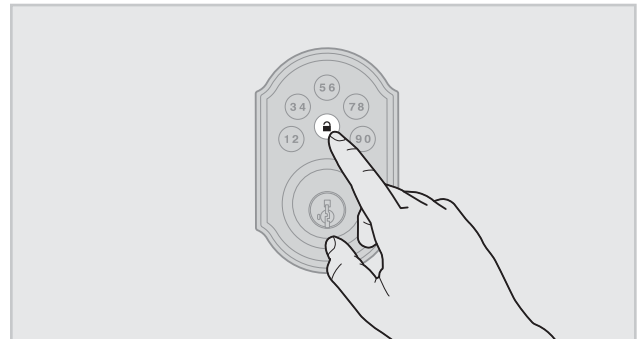

Procedure continued on next page

If programming is successful, the keypad will flash green once with one beep.

If programming is unsuccessful, the keypad will flash red three times with three beeps. Make sure the user code is not a duplicate and that it is between 4 and 8 digits during your next attempt. Make sure to enter a valid Mastercode in step 2.

7. While the door is open and locked, test the user code to make sure it unlocks the door.

D Disabling and Deleting the Mastercode

1. Keep door open. Press and HOLD the Program button until the keypad flashes green (about 5 seconds).

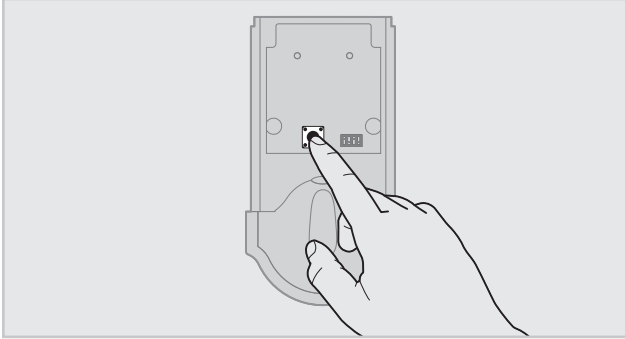

2. Press Lock button once.

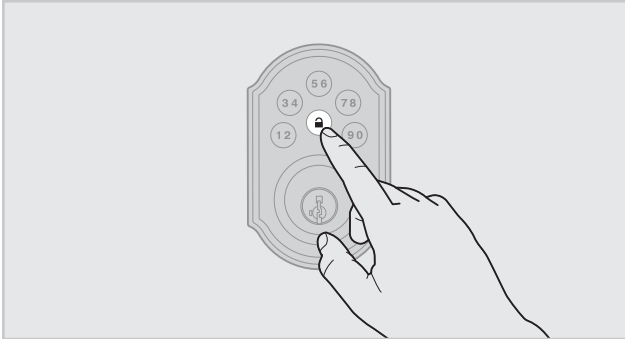

3. Enter Mastercode.

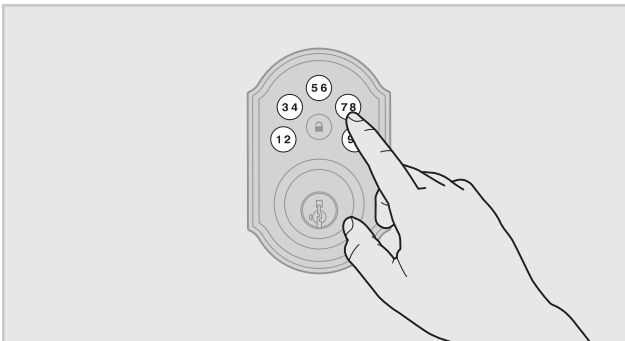

4. Press Lock button once.

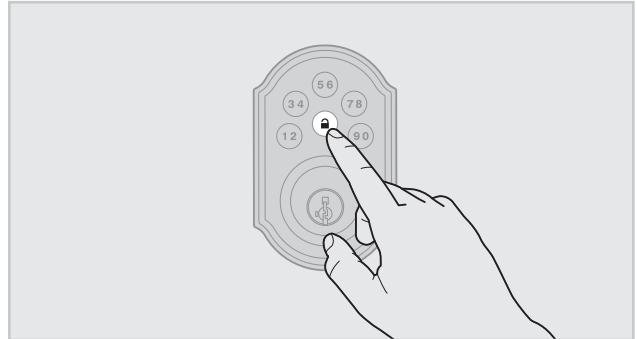

5. Re-enter Mastercode.

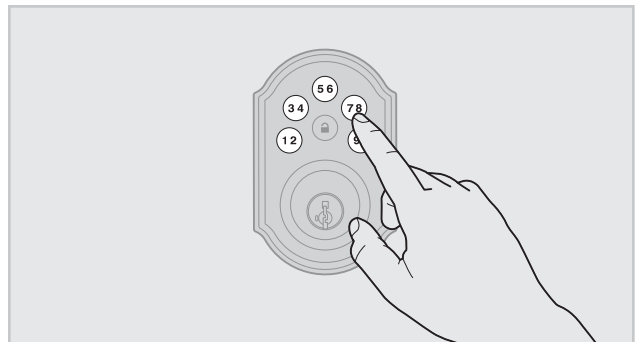

6. Press Lock button once.

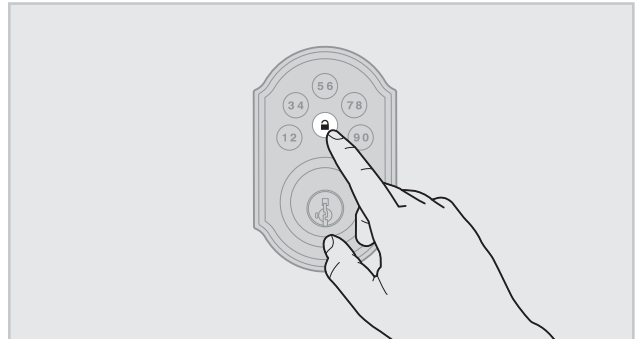

If programming is successful, the keypad will flash green once with one beep.

If programming is unsuccessful, the keypad will flash red three times with three beeps. Make sure the Mastercode has been enabled before trying to disable it. Attempt the procedure again, making sure to enter the same Mastercode in steps 3 and 5.

7. Make sure switch #3 is on, and press the Program button once. If you don't immediately hear three beeps and see the keypad flash green three times, the Mastercode is disabled.

Note: The lock will time out after five seconds.

2 Troubleshooting: Door Jamming and Door Handing

- A The lock jams and the turnpiece does not rotate smoothly.**
- B The lock beeps, the keypad flashes red, and the door cannot lock.**

The door handing process was not executed during installation.

Perform the door handing process in the Installation Guide.

The hole in the door is misaligned.

Disassemble the lock, and reinstall it without the adapter ring on the exterior side of the door.

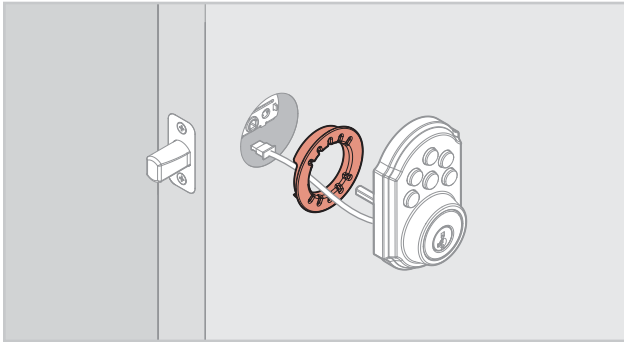

The wrong deadbolt latch is installed.

SmartCode deadbolts require a tapered latch bolt for ease of operation. If the latch being used is from an older lock, it will likely not have a tapered latch bolt. Remove the lock from the door, including the old latch. Replace with the new latch and reinstall the lock.

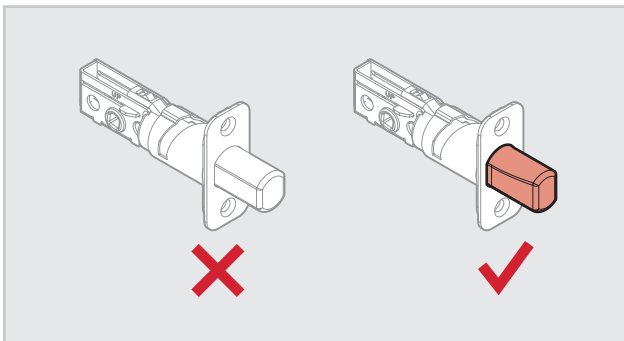

The deadbolt latch and strike are misaligned, causing the latch to bind.

Adjust the tab of the lower strike (for your knob or lever) to help align the upper latch and strike so that the latch bolt enters the strike when the door is locked.

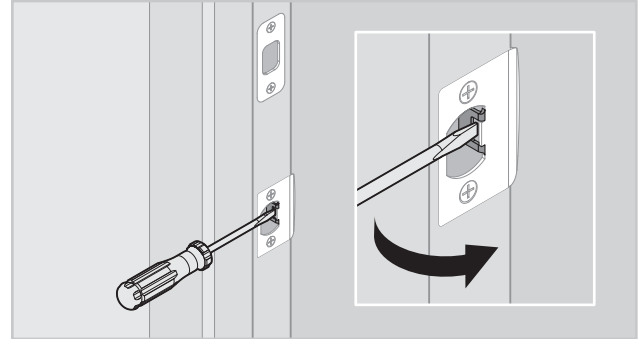

The lower latch and lower strike (for your knob or lever) are misaligned, putting too much load on the deadbolt latch.

As a test, rotate the turnpiece on the deadbolt so the latch is retracted (unlocked), and close the door. If you have to push, pull or lift the door to get it to close, adjust the position of the lower strike.

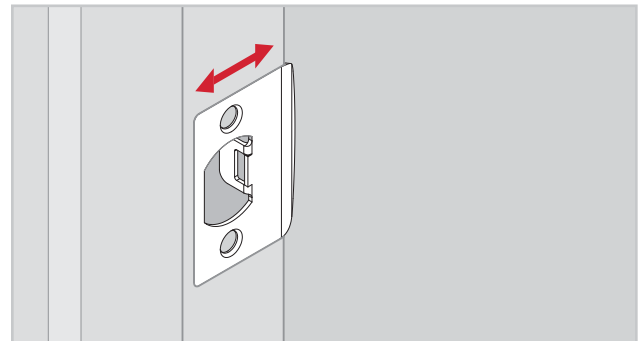

The hole in the door frame for the latch bolt is not drilled deep enough.

Make sure the hole in the door frame is drilled at least 1" (25 mm) deep.

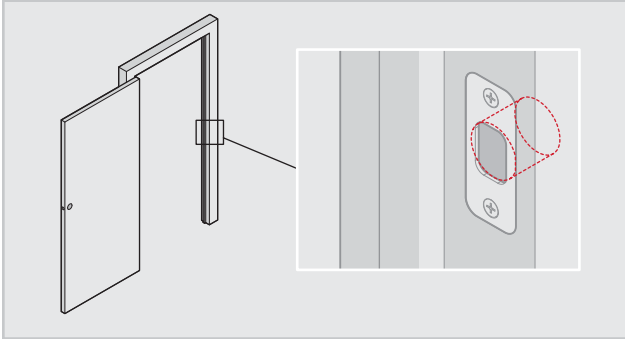

The mounting plate is placing tension on the torque blade.

Attempt to lock and unlock the door with the key. If it is unable to rotate, remove the interior assembly from the mounting plate. Test the key again. If it is still unable to rotate, loosen the screws on the mounting plate and reposition the plate so there is no tension on the cylinder torque blade. Make sure the latch bolt can operate smoothly with the key and reinstall the interior assembly.

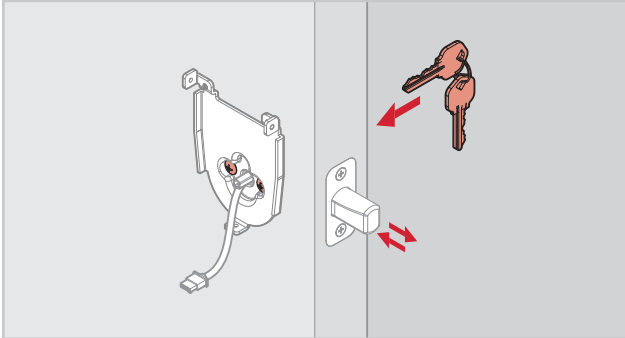

The clutch is disengaged.

Remove the interior assembly from the door. Verify that the lock can be operated smoothly with the key while the interior is removed. Attempt to rotate the turnpiece on the interior assembly. If it does not rotate smoothly, the clutch has become disengaged. Simply rotate the turnpiece 180° clockwise (you will need to use force when rotating the turnpiece, and you will hear it click). This will re-engage the clutch. Align the turnpiece with the torque blade and reinstall the interior assembly on the door.

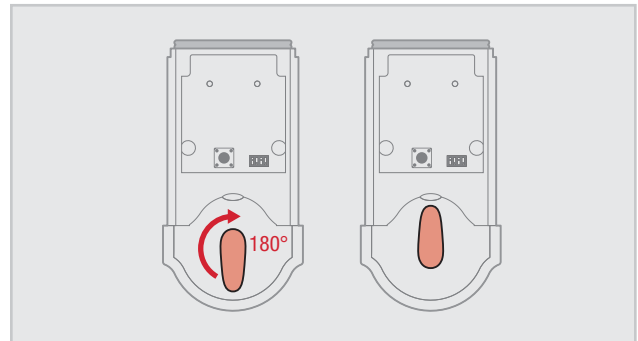

The latch is installed upside down.

A quick way to tell that the latch is upside down is to look at the face of the cylinder. If it is upside down, the latch is installed upside down.

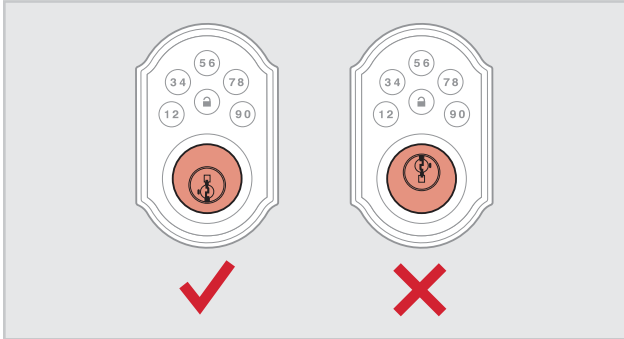

Remove the entire lock assembly from the door, including the latch. Reinstall the latch, making sure the word "UP" faces upward.

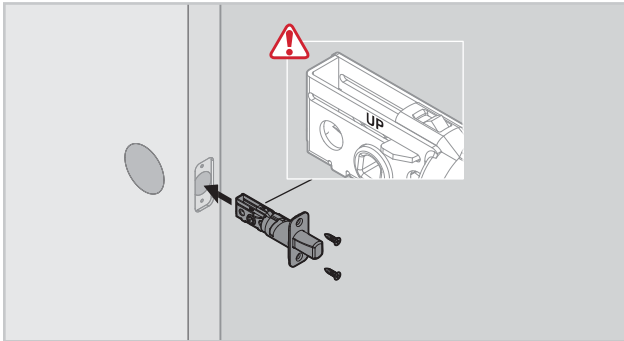

Reinstall the lock. If the turnpiece does not align with the torque blade, rotate the turnpiece 180° clockwise (you will need to use force when rotating the turnpiece, and you will hear it click).

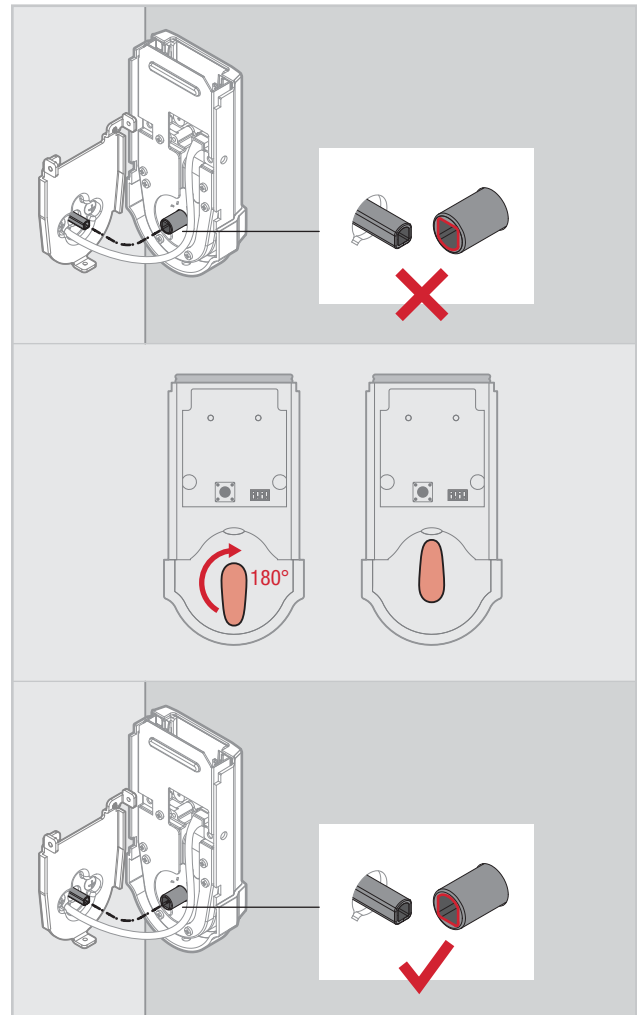

Perform the door handing process once the lock is fully installed.

C The Status LED is solid red after the door handing process.

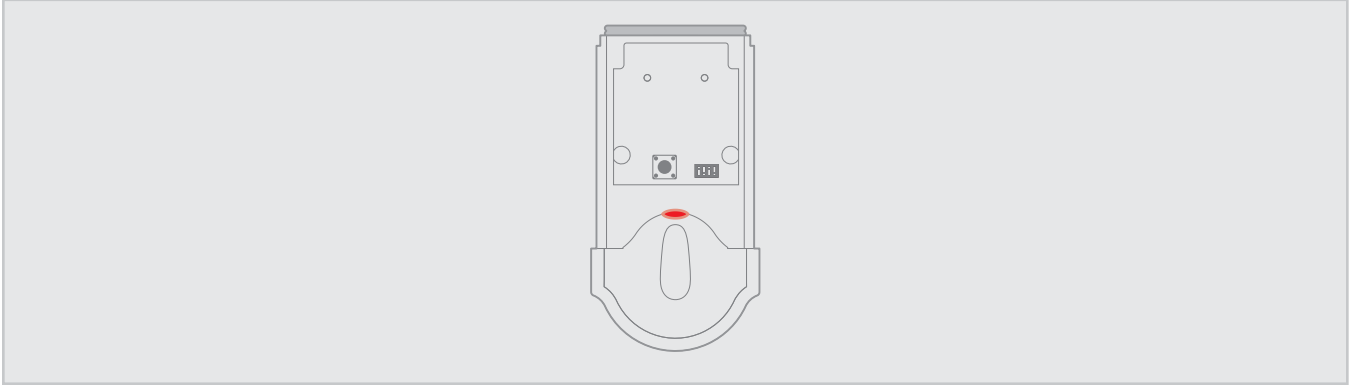

The lock interior is not mounted perpendicular to the ground.

Remount lock interior assembly as illustrated in the Installation Guide.

The hole in the door is misaligned.

Disassemble the lock, and reinstall it without the adapter ring on the exterior side of the door.

The latch is installed upside down.

See page 8.

The battery level is too low.

This is indicated by the keypad flashing red three times with three beeps. Use a fresh set of batteries, and perform the door handing process again.

The latch and strike are misaligned, causing the latch to bind.

If you have not already done so, perform the door handing process while the door is open. If it is successful only when the door is open, the latch and strike are not aligned as they should be. Ensure door preparation is in accordance with the door drilling instructions, available online.

D The deadbolt latch does not extend or retract on its own during the door handing process.

The door handing process was not performed correctly.

Make sure to press and hold the Lock button until the battery pack is fully inserted into the interior assembly and the latch bolt starts to move on its own.

The latch is installed upside down.

See page 8.

The mounting plate is placing tension on the torque blade.

See page 7.

The clutch is disengaged.

See page 7.

The latch and strike are misaligned, causing the latch to bind.

If you have not already done so, perform the door handing process while the door is open. If it is successful only when the door is open, the latch and strike are not aligned as they should be. Ensure door preparation is in accordance with the door drilling instructions, available online.

The keypad is unresponsive.

Make sure switch #3 is on. Use a fresh set of batteries and perform the door handing process. If the latch does not extend or retract, and the lock does not beep, press each individual key on the keypad (one at a time) and listen for beeping sound. If no beeping is heard, this is a keypad error. Contact Technical Support for further troubleshooting.

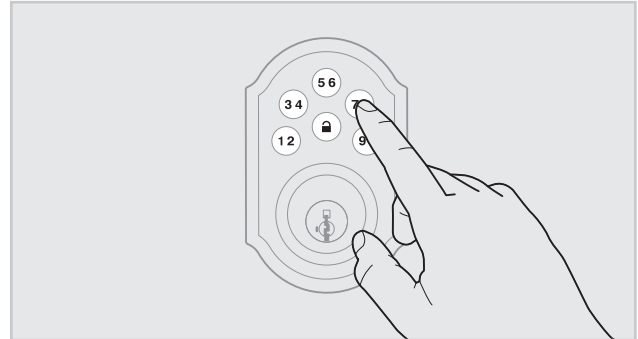

3 Troubleshooting: Keypad

A The keypad is unresponsive.

Keypad error test

Install a fresh set of batteries and turn switch #3 to the ON position. Test each button on the keypad (one at a time) and listen for a beep on each button press. If beeping is not heard on all buttons, contact Technical Support for further troubleshooting.

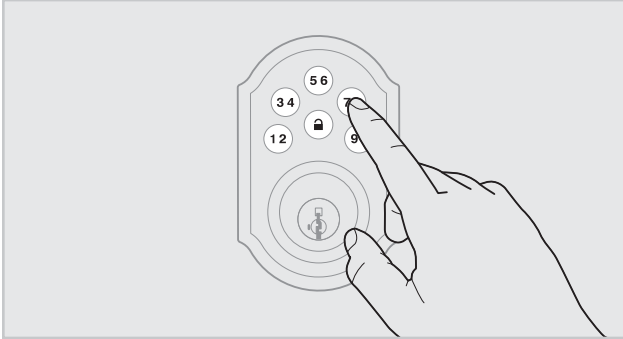

Keypad lockout

If three incorrect codes were entered within one minute, the keypad will lock for 60 seconds.

B The Lock button does not lock the door.

No user codes are programmed.

If there are no codes in the lock, the lock button will not lock the door. This is indicated by the keypad flashing red three times with three beeps. Program at least one user code and test the Lock button again.

The door handing process was not executed.

Perform the door handing process, following the instructions inside the installation guide.

The battery is too low to lock the door.

This is indicated by the keypad flashing red three times with three beeps. Remove the batteries and replace with a fresh set.

The latch is installed upside down.

See page 8.

The mounting plate is placing tension on the torque blade.

See page 7.

The clutch is disengaged.

See page 7.

4 Troubleshooting: Smart Home Systems

A The lock fails to pair with a smart home system.

The lock was not removed completely from another network before being paired with the new network.

Follow your smart home system's instructions to remove (exclude/unpair) the device from any other network. Then, attempt to pair (add/include) the lock again.

The lock is not close enough to the controller.

Some Z-wave systems require that the lock be within 12" of the controller during the pairing process. If the lock has already been installed on the door, remove the interior assembly from the mounting plate. Make sure the batteries are installed, and bring the interior assembly next to the controller. Follow your smart home system's instructions to begin pairing at the controller. The lock may need to remain stationary for 60 seconds during pairing.

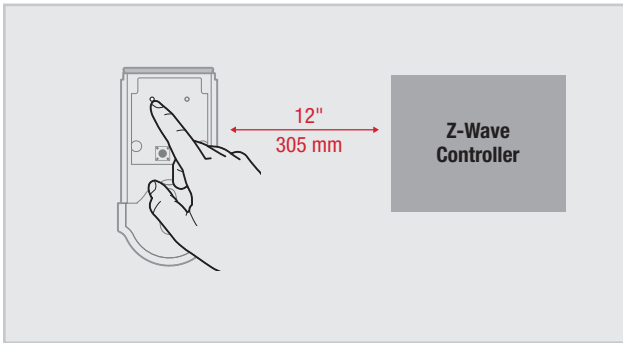

Note: Some locks have an anti-tamper alarm that will sound if the interior is disconnect from the exterior. If this alarm is heard, perform the following:

- Remove the battery pack from the interior.
- Remove the exterior assembly from the door.
- Connect the cable from the exterior assembly to the interior assembly.
- Reinstall the battery pack.
- Perform the pairing process while the interior and exterior are connected.

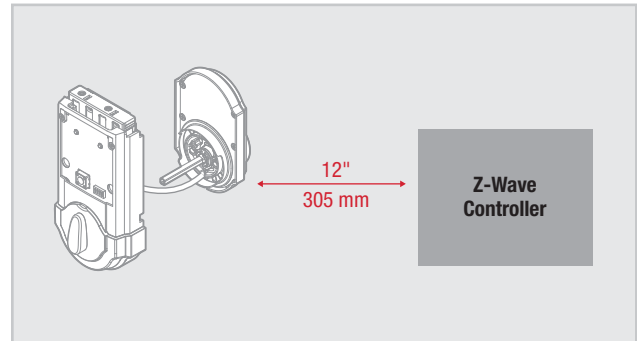

B I can see the lock in my controller, but I can't control it from the controller.

The system needs a repeater or router to reach the lock.

Adding repeaters to your system may help communication between your lock and the controller, especially if they are far away from each other.

The network configuration changed.

If any repeaters or routers in the system were moved since adding the lock to the system, perform the "rediscover" process in your system's user interface.

The lock is in sleep mode.

If the lock has been unable to communicate with the system after multiple attempts, it will go into sleep mode. Lock and unlock the door

with a key so that the lock status transmits to the system. If it still does not communicate, remove (exclude/unpair) the lock from your system. Then, pair (add/include) the lock with your system again. If the problem persists, add a repeater or router between the controller and lock if none presently exist in the system.

The light module or switch is not beaming capable.

Z-Wave locks: Ensure the light module or switch located between the controller and lock is beaming capable.

ZigBee locks: Ensure the router is reachable by both controller and lock.

5 Troubleshooting: Battery

A The batteries drain within one day.

The lock must be replaced. Contact Technical Support.

B The batteries drain within one week.

Keypad error.

See “Keypad error test” on page 11.

The Wireless Card LEDs are staying on.

Remove the battery pack, press and hold the program button for five seconds. Replace the battery pack. If the Wireless Card LEDs continue to stay on, contact Technical Support.

C The batteries drain within a few weeks.

The smart home system’s user interface falsely reports a low battery.

If you receive an alert from your smart home system indicating that the battery is low, confirm this is true at the lock. Turn on switch #1 so that the status LED flashes every six seconds. If the LEDs turn amber or green, followed by a red flash, the battery is low. If the red flash is not seen, the battery is not low. This is an error on the smart home system side that will often be fixed when the lock is manually locked or unlocked.

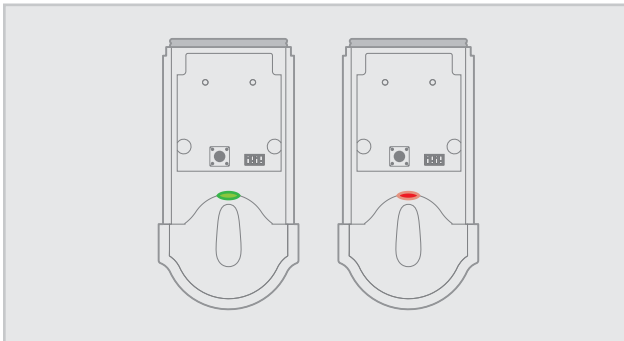

The smart home system controller’s communication with the lock is draining the battery.

Remove the lock from your system. Put a new set of batteries in the lock. Operate the lock in stand-alone mode for a week. If the batteries drain within the week, the problem resides in the lock. If the batteries do not drain, the problem may be the smart home controller. Call Technical Support.

The smart home system controller’s ping frequency is too high.

Decrease the ping frequency from the controller to the lock to the lowest possible setting.

6

Battery FAQ

How long will the lock operate on a set of batteries?

Based on 10 operations per day, a single, new set of Alkaline batteries will operate the lock for over a year.

What type of batteries do you recommend?

For best results, use new non-rechargeable Alkaline batteries only.

I am planning to be away for several months. Will my lock operate when I get back?

When the system is idling, it consumes minimum power (very close to battery shelf life.) With alkaline batteries, the lock should be operable after years of idle.

I replaced my batteries less than a year ago and need to replace them again.

Check your door alignment. If the deadbolt makes several unsuccessful attempts to lock or unlock the door, it may mean that the door is warped and the latch does not line up correctly with the strike. Operating the lock excessively reduces battery life. Avoid turning on the keypad light unnecessarily.

What settings should I use to get the maximum battery life out of my lock?

Set switches #1, #2, and #3 to the OFF position.