











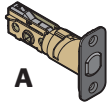
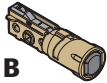

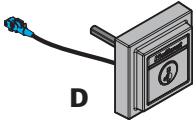



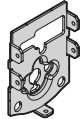



Required tools	Parts in the box					
Ruler  Phillips screwdriver 	Latch with rectangular faceplate  A	Drive-in latch  B	Strike  C	Exterior assembly  D	Adapter ring  E	Keys  F
Additional tools (depending on application) Hammer  Wood block 	Mounting plate  G	Interior assembly  H	Battery pack  J	Interior cover  K	Batteries  L	SmartKey tool  M
	Latch screws  N P 03809	Strike screws  Q R 46780	Mounting plate screws  S 64844	Interior assembly screws  T 49191	Interior cover screws  U 64109	

Note: Part numbers are printed on screw bags.

1 Prepare the door and check dimensions

If drilling a new door, use the supplied template and the complete door drilling instructions available at www.kwikset.com/doorprep.

A Measure to confirm that the hole in the door is either 2-1/8" (54 mm) or 1-1/2" (38 mm).

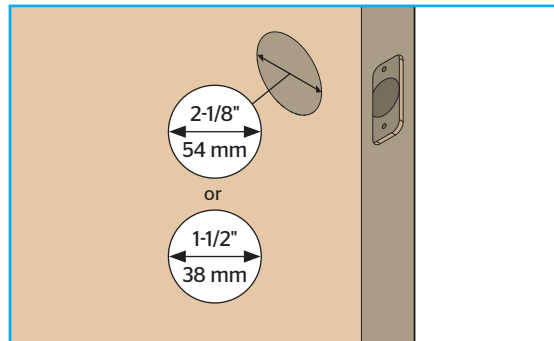

Note: Additional door preparation may be required for doors with 1-1/2" (38 mm) holes. Consult the deadbolt drilling instructions at www.kwikset.com/doorprep

B Measure to confirm that the backset is either 2-3/8" or 2-3/4" (60 or 70 mm).

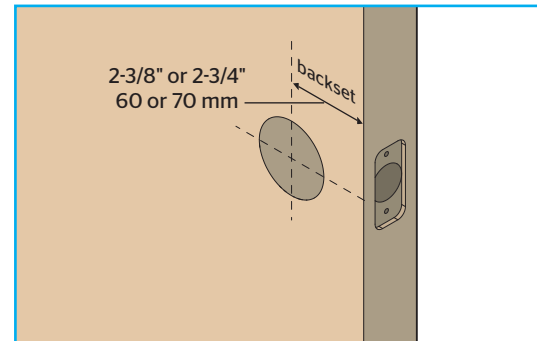

C Measure to confirm that the hole in the door edge is 1" (25 mm).

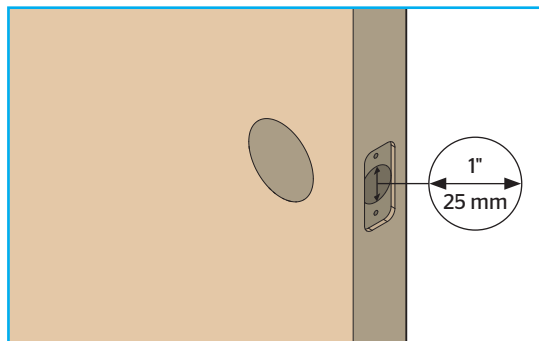

D Measure to confirm that the door is 1-3/4" (44 mm) thick.

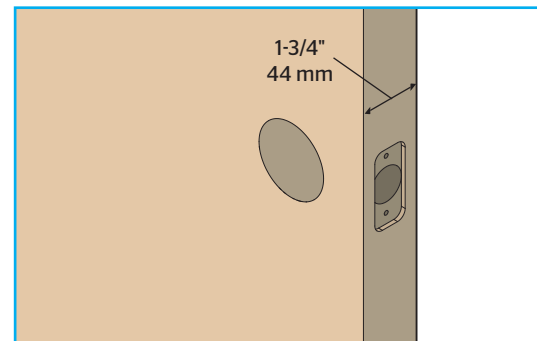

2

Install the latch and strike

A Is the door edge chiseled?

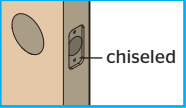
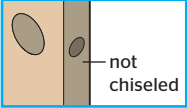
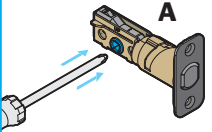
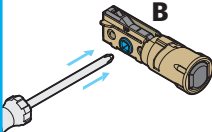
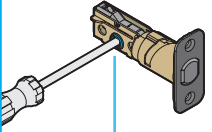
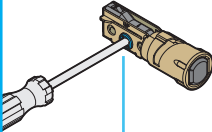
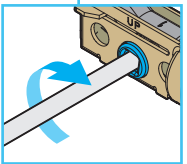
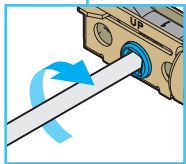
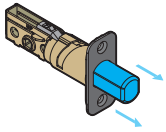
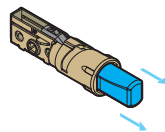
YES	OR	NO
		
Use latch "A". If the latch bolt is not already extended, extend the latch bolt as shown.		Use latch "B". If the latch bolt is not already extended, extend the latch bolt as shown.
		
		
		
		

B Hold the latch in front of the door hole, with the latch face flush against the door edge.

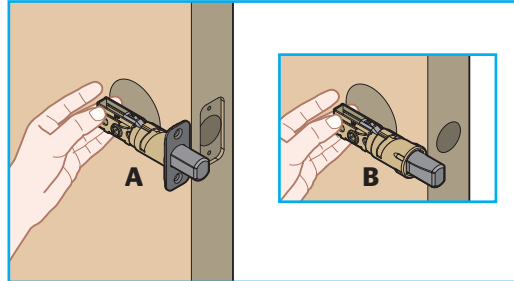

C Is the D-shaped hole centered in the door hole?

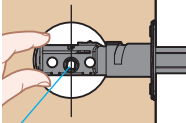
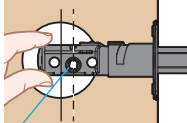
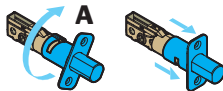
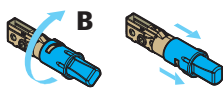
YES	OR	NO
		
D-shaped hole centered		D-shaped hole NOT centered
No adjustment is required. Proceed to next step.		Rotate latch face as shown to extend latch.
		
		

D Which latch are you installing?

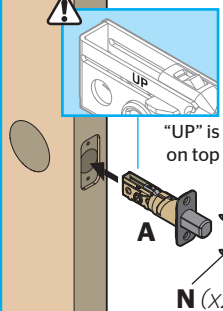
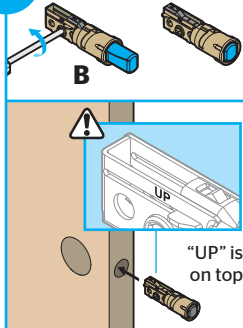
Latch "A"	OR	Latch "B"
		
"UP" is on top		"UP" is on top
N (x2)		wood block

E Install strike on the door frame.

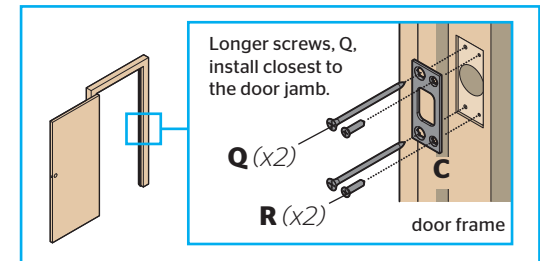

⚠ Make sure the hole in the door frame is drilled a minimum of 1" (25 mm) deep.



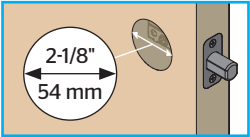
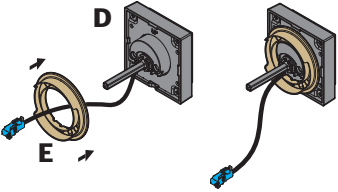
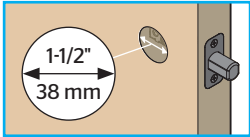

Note: The longer screws, Q, (3" / 76 mm) must be used to maintain highest security.

3 Install the exterior assembly

A What is the diameter of the hole in the door?

<p>Diameter is 2-1/8" (54 mm)</p>  <p>"E" is required for installation. Install "E" on "D".</p> 	<p>or</p>	<p>Diameter is 1-1/2" (38 mm)</p>  <p>"E" is not needed for installation. Discard "E".</p> 
---	------------------	--

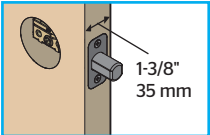
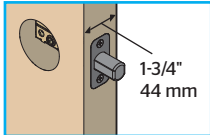
B What is the thickness of your door?

<p>Door is 1-3/8" (35 mm) thick</p>  <p>Kevo Contemporary does not support this door thickness.</p>	<p>or</p>	<p>Door is 1-3/4" (44 mm) thick</p>  
--	------------------	---

C Install exterior assembly and mounting plate.

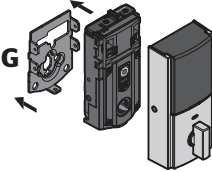
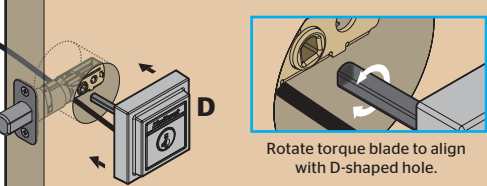
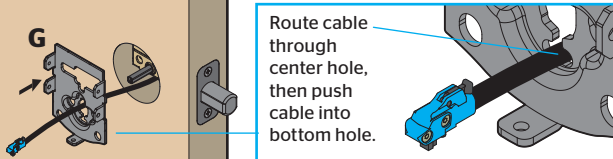
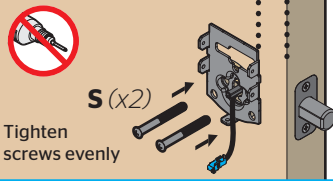
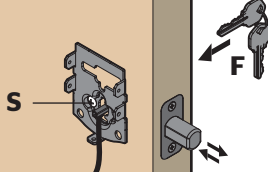
<p>a Locate mounting plate (G). Note: It is on the back of the interior assembly.</p> 	
<p>b Cable goes underneath latch.</p>  <p>Rotate torque blade to align with D-shaped hole.</p>	
<p>c</p>  <p>Route cable through center hole, then push cable into bottom hole.</p>	
<p>d</p>  <p>Keep parallel to edge of door</p> <p>Tighten screws evenly</p>	
<p>e</p>  <p>Insert key and test latch. If latch does not extend or retract smoothly, adjust screws (S). Remove key when finished and make sure the latch bolt is fully extended.</p>	

4 Install the interior assembly

A Remove battery cover and battery pack from interior assembly.

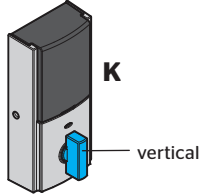
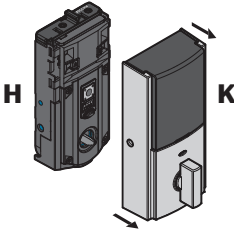
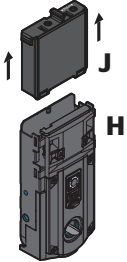
<p>a Make sure turnpiece is in the vertical position.</p> 	<p>b Remove interior cover.</p> 	<p>c Remove battery pack.</p>  <p>Do not install batteries yet.</p>
--	---	--

B Connect cable and install interior assembly.

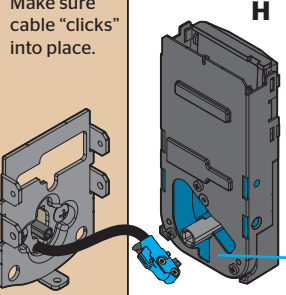
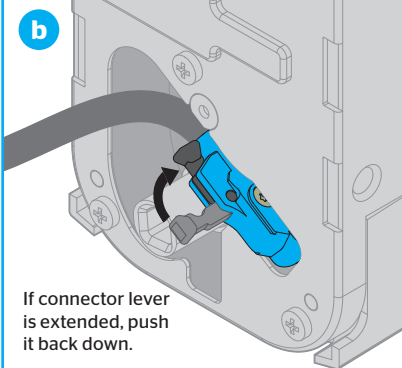
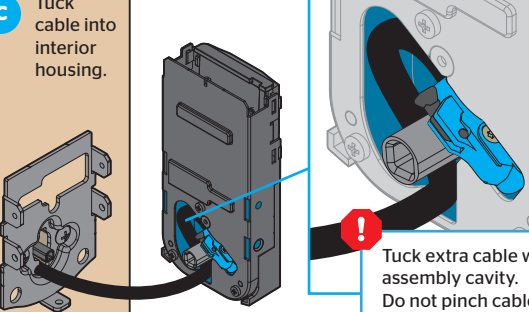
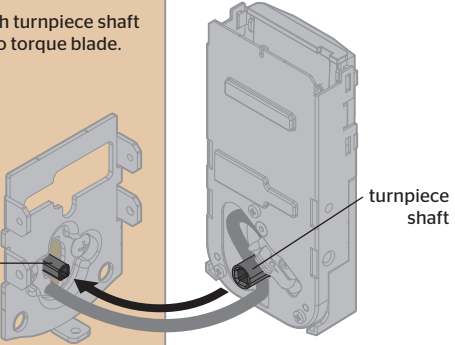
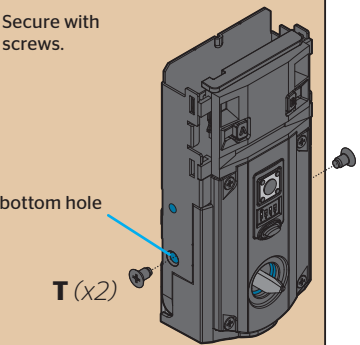
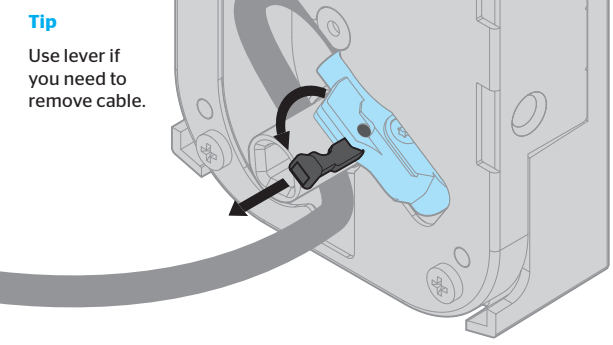
<p>a Make sure cable "clicks" into place.</p> 	<p>b</p>  <p>If connector lever is extended, push it back down.</p>	<p>c Tuck cable into interior housing.</p>  <p>Tuck extra cable within assembly cavity. Do not pinch cable during final install.</p>
<p>d Push turnpiece shaft onto torque blade.</p>  <p>torque blade</p> <p>turnpiece shaft</p>	<p>e Secure with screws.</p>  <p>bottom hole</p> <p>T (x2)</p>	<p>Tip</p> <p>Use lever if you need to remove cable.</p> 

5 Perform the door handing process

This step will teach the lock the orientation of your door and is crucial for lock operation.

A Install 4 AA batteries in the battery pack.

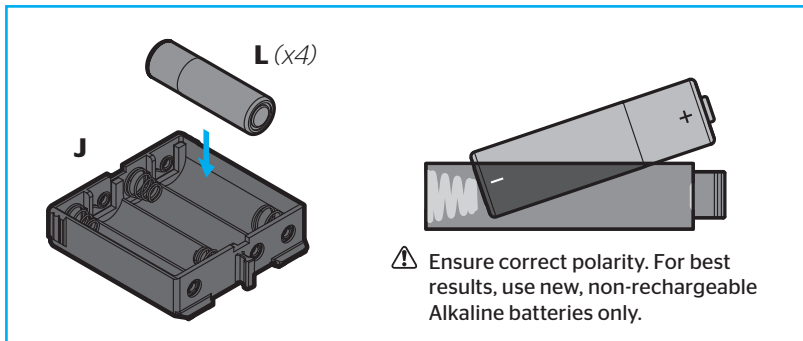

B **IMPORTANT:** Make sure the door is open. Insert the battery pack while **PRESSING AND HOLDING** the Program button. Release the button when the battery pack is all the way inside the lock interior.

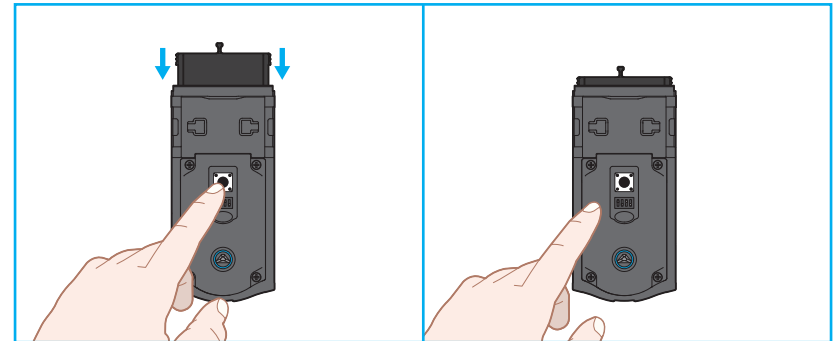

C **IMPORTANT:** The Status LED will flash red and green, and the lock will beep. Press and release the Program button again. The latch bolt will retract and extend on its own.

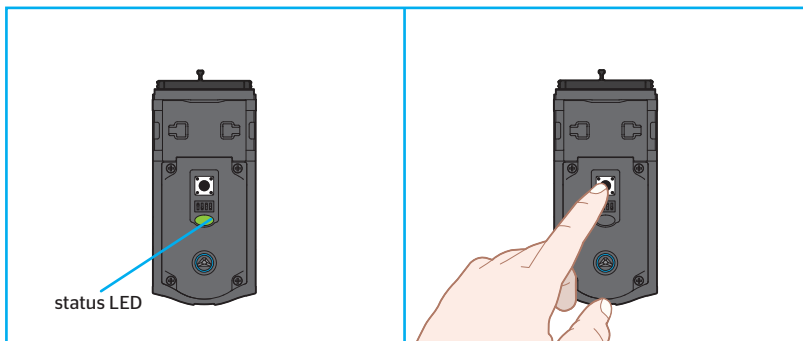

D Did the latch bolt retract and extend on its own?

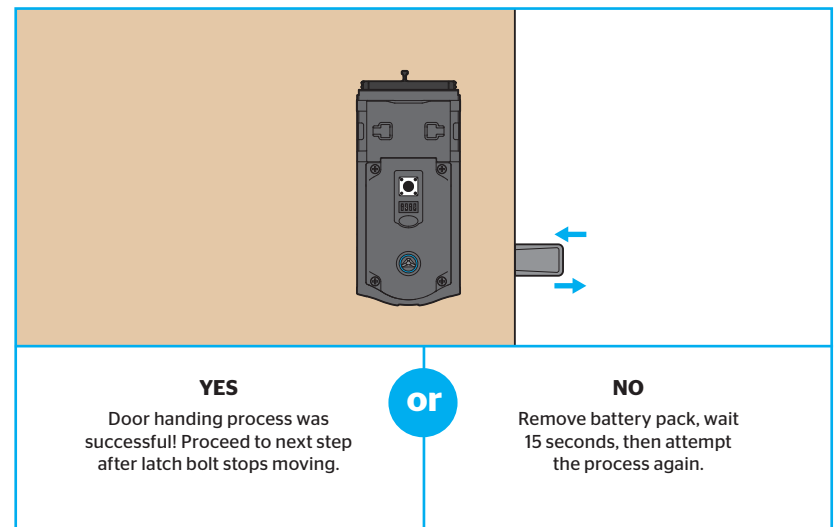

6 OPTIONAL: Re-key the lock

If desired, the lock may be re-keyed to work with your existing key. See the supplied SmartKey Re-key instructions for more information.

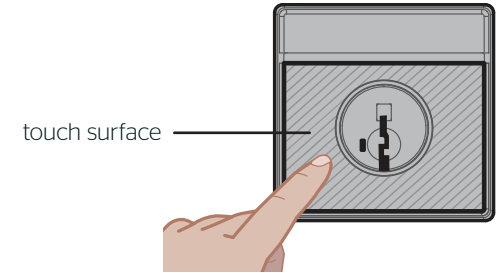

7 Download the app and set up your smartphone

If this lock was professionally installed (or installed by someone other than the homeowner), make sure that step 7 is performed by the homeowner.

A Download the Kevo app at kwikset.com/kevo/app or scan the QR code below.



B Follow the instructions inside the app to create an account and enroll your first smartphone.



C Continue to follow the instructions inside the app to calibrate the lock so it learns where you keep your phone during normal use.

D Send eKeys to family and friends with Kevo-compatible smartphones.

Normal use

When using your phone to lock and unlock the door, make sure the phone is on, Bluetooth is enabled, and the Kevo app is running in the background.

Always stand at an extended arm's reach, and avoid holding your device close to the lock.

You may hold the phone in your hand, pocket, bag or purse as long as there is a clear line of sight between the lock and the phone.



Locking the door

Touch the lock exterior on the touch surface. The light string will display the following animations, the lock will beep once, and the door will lock.

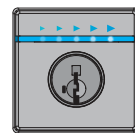

Blue sweep

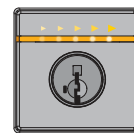

Orange sweep, moving towards door edge

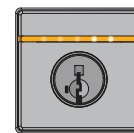

Last 2 LEDs remain on for 2 seconds

LED sweep direction will follow the bolt direction when locking and unlocking the door

Unlocking the door

Touch the lock exterior on the touch surface. The light string will display the following animations, the lock will beep twice, and the door will unlock.

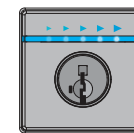

Blue sweep

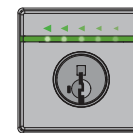

Green sweep, moving away from door edge

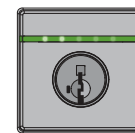

First 2 LEDs remain on for 2 seconds

8

Install the interior cover

Important information about the interior cover:

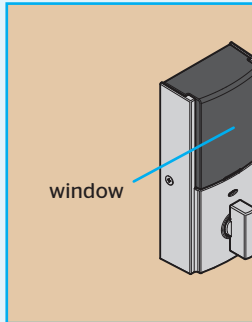

The interior cover will be secured by three screws to prevent someone from removing the battery or tampering with your lock's settings. The window on the interior cover is locked by default.

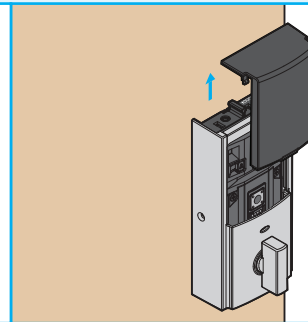

If the window is unlocked, it can slide up for more convenient access to programming buttons while the cover is installed. Note: The interior cover and screws must be removed for battery pack access.

If you want to keep the window locked:

a Install cover. **K**

b Install screws. **U (x3)**

If you want to unlock the window:

a Remove security screw. **K**

b Install cover. **K**

c Install screws. **U (x3)**

9

Battery Replacement

a Slide cover up. **K**

b Remove battery pack. **J**

c Replace batteries. **J**

⚠️ Ensure correct polarity. For best results, use new, non-rechargeable Alkaline batteries only.

Kevo at a Glance

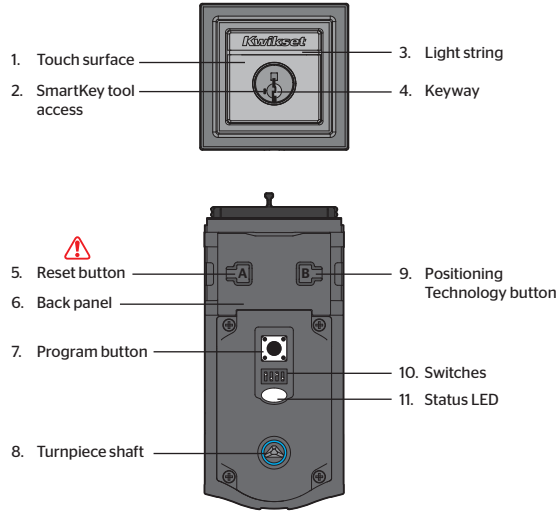

1. Touch Kevo anywhere on the metallic surface below the light string to lock and unlock.
2. Insert your SmartKey tool here when rekeying your lock to work with your existing key.
3. Changes color to communicate with you.
4. Insert your standard key here.
5. **⚠️** Only use to reset Kevo to delete all eKeys and fobs. See "System Reset" for more information.
6. Where all the programming features are located.
7. Use to enroll phones and fobs.
8. Engages with turnpiece when interior cover is installed. When the cover is removed, the turnpiece shaft can be used to manually lock and unlock the door.
9. Use to reset Kevo activation range.
10. Use to enable and disable the Status LED, Triple Touch Lock, Audio, and Auto-Lock.
11. Communicates whether the door is locked or unlocked and flashes red for a low battery alert. Can be turned on and off by Switch #1.

Kevo-Compatible Devices

Smartphones and Smart Devices

A Kevo-compatible smartphone (or other mobile internet-connected device or tablet) must have Bluetooth Smart Ready/ Bluetooth 4.0 and an app specific to the device must be installed. Find out if your device is compatible at www.kwikset.com/kevo/devices.



Kevo Fob

A Kevo Fob is a Bluetooth device that provides the same touch-to-open convenience as a smartphone.

Up to eight fobs can be enrolled in a single Kevo lock. A single fob can be enrolled in up to 25 different Kevo locks.

Note: You may choose to use only Kevo fobs, only smartphones or a mix of both in your Kevo system.

Standard Key

Always make sure you have access to your standard key.

Switches



Switch 1

Status LED

Door lock status LED blinks every 6 seconds. ON position is factory default.

Switch 2

⚠️ Triple Touch Lock

See "Triple Touch Lock." OFF position is factory default.

Switch 3

Audio

Beeping sound is heard during programming and normal operation. ON position is factory default.

Switch 4

⚠️ Auto-Lock

Automatically re-locks door 30 seconds after unlocking. OFF position is factory default.

Triple Touch Lock and Auto-Lock

Triple Touch Lock allows you to lock the door from the outside without the use of a smartphone or fob. You might use Triple Touch Lock if you are using only a standard key in your system but wish to lock the door by touch, if your smartphone or fob is disabled, or if you have a visitor in your home that will leave and lock the door behind them.

To lock the door with this feature, tap the touch surface three times, pausing briefly between each touch. The lock will perform the lock light sequence (page 7).

To enable Triple Touch Lock, set Switch #2 to the ON position.

Auto-Lock will automatically re-lock the door 30 seconds after unlocking. To enable Auto-Lock, set Switch #4 to the ON position.

Both features are OFF by default.

⚠️ CAUTION: With these feature enabled, it is possible to lock yourself outside if you don't have an enrolled smartphone, Kevo fob or standard key with you.

System Reset

⚠️ WARNING: Resetting your Kevo system will restore your lock to factory settings and delete all smartphones and fobs from Kevo's memory.

If you wish to perform a system reset, **press and hold** the Reset button on the back panel for 10 seconds until the lock beeps and the light ring flashes red.

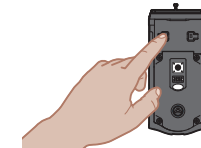

Phones: After a system reset, you will need to re-enroll your Owner phone. You will still be able to send eKeys at no charge to anyone who previously had an active eKey at the time of reset.

Fobs: After a system reset, all fobs will need to be re-enrolled. See the online Troubleshooting guide for instructions.

Light String Notifications

Out of Range

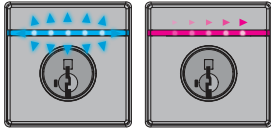

Blue pulse Magenta sweep

Invalid Credential

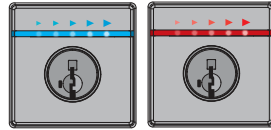

Blue sweep Red sweep

No Credential

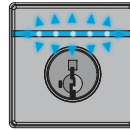

Blue pulse

Deadbolt Jammed

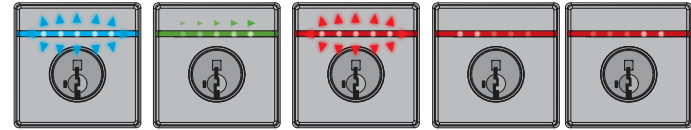

Blue pulse Green sweep Red pulse 2 Red LEDs alternate between right and left

Deadbolt Low Battery

After normal locking/unlocking light string notifications

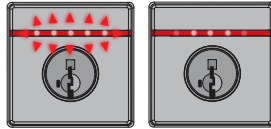

Red pulse 3 center red LEDs

Fob Low Battery

After normal locking/unlocking light string notifications

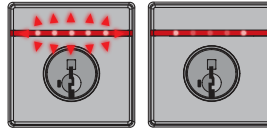

Red Pulse 2 outer red LEDs

Unit Thinking

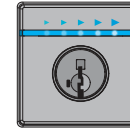

Blue sweep

Boot Up/LED Test

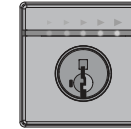

Multicolor sweep

- ▷ White
- ▷ Orange
- ▷ Red
- ▷ Magenta
- ▷ Blue
- ▷ Green
- ▷ White

Status LED Notifications

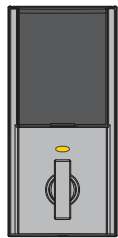

Amber flash
Door is locked



Green flash
Door is unlocked



Red flash
The 4 AA batteries in the Kevo interior are low and need to be replaced.

Advanced Features

Positioning Technology

The Kevo smart lock features a unique positioning technology that can tell if your device is inside or outside your home to help prevent your door from being unlocked by unauthorized users while your device is inside.

For additional security, Kevo will also limit the activation range on the outside. The Kevo smart lock will learn about your entryway and the typical positions where you might keep your phone during normal use.

If you find that the Kevo activation range is not ideal for your use, you can reset what Kevo learned, and Kevo will learn your environment again. Quickly press and release the Positioning Technology button (B) on the lock interior. Kevo will learn your environment again.

History Log

A history of the lock's activity may be viewed through the Kevo app or by logging into the web portal: www.mykevo.com.

Notifications

The Kevo app can send notifications when the door is locked and unlocked by eKey holders. You can choose to receive the system's default notifications or set up custom notifications to monitor a specific user or time frame.

Dual Factor Authentication

Kevo features an optional, added-security passcode that you can enable inside the app to be used in addition to the app's password. Enabling the passcode will require you to enter a 4-digit PIN whenever you access the app, and it protects your Kevo account against unauthorized changes when your phone is unlocked.

Kevo Plus

With Kevo Plus, you will be able to lock and unlock your home and check whether your door is locked or unlocked when you are away from home. You can upgrade to Kevo Plus inside the Kevo app. Visit www.kwikset.com/kevo/kevo-plus for more information.

Connect Smart Products

Connect Kevo to select smart products. In the Kevo app, tap the gear icon to connect to smart products (iOS only: select "Preferences"). Visit www.kwikset.com/kevo/support for more information.

Important Safeguards

1. Read all instructions in their entirety.
2. Familiarize yourself with all warning and caution statements.
3. Remind all family members of safety precautions.
4. Always have access to your lock's standard key.
5. If using the Triple Touch Lock or Auto-Lock features, make sure to have your smartphone, fob or standard key with you to prevent locking yourself out.
6. Familiarize yourself with all light ring error notifications.
7. Replace low batteries immediately.
3. Protect the password to your Kevo app and web portal accounts.
4. When sending an eKey, always double-check that you are sending it to the correct recipient.
5. Protect and restrict access to your smartphone so that your app settings cannot be altered without your knowledge.
6. Enable the Kevo app's security passcode so that your app settings cannot be altered without your knowledge.
7. When sending eKeys, be aware of the difference between an Admin user and other users in the system: an Admin user can send, disable and delete eKeys.
8. If your smartphone is lost or stolen, use the Kevo web portal (www.mykevo.com) to disable it.
9. If a fob in your Kevo system is lost or stolen, reset your lock to delete it from memory.

Preventing Inadvertent Unlocking of Your Door

 **WARNING:** Failure to follow these safeguards could result in your lock opening inadvertently.

1. Avoid keeping and storing phones and fobs unnecessarily close to the lock when inside the home.
2. Restrict access to your Kevo lock's back panel and routinely check your settings to ensure they have not been altered without your knowledge.

 **CAUTION:** As with any radio-based technology, it should be noted that the accuracy and reliability of the Kevo lock's inside-outside sensor cannot be guaranteed. Users should not rely solely on the Kevo lock's sensor for security purposes and should always use caution. This manufacturer assumes no responsibility for incorrect results or damages resulting from the use of the Kevo lock's sensor.

Certain home configurations may impede the Kevo lock's sensor more than others. Example: *Your home office is located next to your entryway, and part of the office extends past the front door, jutting into the front yard. If your device is being actively used in that office extension, the Kevo lock's sensor could possibly detect the device as being outside of your home while that device is in active use.*

 **WARNING:** This Manufacturer advises that no lock can provide complete security by itself. This lock may be defeated by forcible or technical means, or evaded by entry elsewhere on the property. No lock can substitute for caution, awareness of your environment, and common sense. Builder's hardware is available in multiple performance grades to suit the application. In order to enhance security and reduce risk, you should consult a qualified locksmith or other security professional.